

AP-ART

A COMPENDIUM OF PUZZLE DESIGNS



BY

STEWART T. COFFIN

AP-ART

A COMPENDIUM OF PUZZLE DESIGNS

BY
STEWART T. COFFIN

AUGUST 2003

PRODUCED BY PUZZLE WORLD PRODUCTIONS
JOHN RAUSCH, EDITOR

*Puzzle World Productions
3119 N. Waynesville Road
Oregonia, OH 45054-9766*

First published in July 2003 by Puzzle World Productions

Typeset in Garamond Pro, Trajan Pro, and Helvetica using Adobe InDesign

ISBN 0-9666361-2-0

The following notes regarding the cover photographs are by John Rausch.

FRONT COVER:

Jupiter (#7) in zebrawood, Osage orange, tarara, blue mahoe, breadnut & Honduras mahogany by Stewart Coffin

BACK COVER:

TOP LEFT: **Fixed Sticks** in tamarindo, Santos rosewood, Macassar ebony, Honduras rosewood & goncalo alves by Lee Krasnow. This puzzle is a symmetrical version of **Broken Sticks** (#32). It is not a puzzle Stewart includes in his list of designs. Where Broken Sticks is like **Twelve Point** (#33), having identical permutation of the piece ends, **Fixed Sticks** is like **Third Stellation** (#50-B) having six identical pieces except for color. Because none of the sticks are “broken” by permutations, Lee calls it **Fixed Sticks**. Though not included in Stewart’s list of designs, he does make reference to how one might make twelve triangular sticks into this interlocking assembly in *The Puzzling World of Polyhedral Dissections* on page 82 and figure 97.

TOP RIGHT: **Jupiter** (#7) in zebrawood, bloodwood, canarywood, Indonesian rosewood, satinwood & bubinga by Bart Buie.

CENTER: **Star** in Mexican kingwood, Macassar ebony, cocobolo, bois de rose & figured bocote by Lee Krasnow. Stewart made his **Sirius** (#4) pieces using a six-sided center block and two tetrahedral blocks (see Appendix A), to eliminate the tendency for the tips to break off. Subsequently, with **Star** (#4-A), he used different woods for the tetrahedral-block ends to add a color symmetry challenge with two solutions. Lee has gone a step further by making the six-sided center blocks using two prism blocks from different woods and matching tetrahedral-block ends. Using four woods, this creates a design with color symmetry similar to **Four Corners** (#6). There are two color symmetry solutions, each of which can be done right or left handed. The two solutions show color symmetry on the four-fold axes. Lee found an unexpected third solution that shows radial color symmetry along just one of the three-fold axes. This solution is shown in the photograph.

BOTTOM LEFT: **Rosebud** (#39) in Mexican cocobolo & canarywood by Lee Krasnow. It is expanded (“bloomed”) just about as much as possible without falling into a pile.

BOTTOM RIGHT: **Second Stellation** (#14-A) in zebrawood by Lee Krasnow.

CONTENTS

| | |
|--|-----|
| Foreward | 1 |
| Introduction | 3 |
| Part 1 — Background and Commentary | 5 |
| How It All Began | 5 |
| The Cast Epoxy And Plastic Phase | 5 |
| The Sculptural Art That Comes Apart | 6 |
| The Craft Fair Years | 6 |
| Buttons And Beads | 6 |
| Museum Exhibits | 7 |
| Books | 7 |
| Part 2 — AP-ART Designs | 9 |
| Epilog | 129 |
| Summary | 129 |
| Reflections | 131 |
| Appendix A — Building Blocks | 133 |
| Appendix B — AP-ART Designs and Castle Creations used in IPP Exchanges | 134 |
| Appendix C — AP-ART Instructions, Descriptions and Other Printed Matter | 135 |
| Instructions | 135 |
| Unnumbered and Miscellaneous Publications | 138 |
| Brochures Issued | 139 |
| Magazine Articles on AP-ART | 139 |
| Index | 141 |

FOREWARD

I started collecting puzzles in 1964 at the age of nineteen. After a couple of years the Vietnam War and the United States Navy distracted me for a few years. When I returned to civilian life, my interest was still there, but I limited myself to Martin Gardner's books and his monthly article in *Scientific American*. Then came Pieter van Delft and Jack Botermans' *Creative Puzzles of the World* in 1978 and Jerry Slocum and Jack Botermans' *Puzzles Old & New* in 1986. *Puzzles Old & New* was a lot like my *Puzzle World* website—hundreds of wonderful puzzles and not much information about how to get them. I was fascinated with the information about the six-piece burr and especially in the puzzles made by Stewart Coffin. I had access to *The Journal of Recreational Mathematics* and quickly got myself a copy of Bill Cutler's article on six-piece burrs. I can't remember how I found Stewart's address, but I wrote to him for information. In his reply, he listed six or seven puzzles available with names like Hexagonal Prism, Second Stellation, Triumph, etc. and descriptions that didn't make them sound all that interesting. Plus, most were \$30 or more! I tossed it.

In 1993, I met Tom Lensch at the Artistry in Wood show held annually in Dayton, Ohio. He had quite a few puzzles for sale, all rectilinear burrs of one sort or another except for a couple of diagonal burr variations. We talked for quite awhile and I bought five or six burrs from him. He told me about the upcoming exhibition at the Atlanta International Museum of Art and Design. I called and ultimately ended up talking with Tom Rodgers. He must have thought I was a seasoned collector, because he told me about, and invited me to the first Gathering For Gardner. Well, that did it for me! As a computer programmer since 1965, an amateur magician, recreational mathematician, skeptic and puzzle collector, the attendees bowled me over! I also learned what a Hexagonal Prism and many more Stewart Coffin puzzles looked like.

Since then, the puzzle collection has grown and, through the International Puzzle Parties started and directed by Jerry Slocum, I have met hundreds of creative people and made close friends with a few of them—Stewart Coffin being among them.

I made my first trip to Lincoln, Massachusetts in 1998 to photograph some of his puzzles and discuss the possibility of putting *The Puzzling World of Polyhedral Dissections* on the Internet and making a CD-ROM version. After I showed him some samples, he agreed and I spent the next couple of months converting it to HTML for the website. I didn't anticipate the problem I would have converting most of the illustrations so they would work on the 72 pixels-per-inch monitors for the Macintosh and 96 pixels-per-inch monitors for the PC. It took forever to touch up or redraw them.

Stewart also allowed me to put page images from both the 1985 and 1992 versions of his *Puzzle Craft* booklets on the website and CD-ROM. Both the website and the CD-ROM have been popular and have brought several new collectors and craftsmen into the puzzle community. Notably, Bart Buie and Lee Krasnow, who have many puzzles featured in this book.

When Stewart published his first AP-ART in 2000, he allowed me to convert it to HTML and put it on the *Puzzle World* website. It turned out all right, but I was never that happy with it. First of all, I needed a lot more high quality photographs. Since then, I have been able to photograph most of the significant puzzles by visiting a few long-time Stewart Coffin collectors. When Stewart published an updated AP-ART this year, he had added many drawings, making it much more than just a list of his designs.

What you are holding is a deluxe version of Stewart's 2003 AP-ART. The entire work was typeset for color reproduction. To keep it from being 300 pages long and costing twice as much, the drawings are smaller than those in Stewart's version. Many scans were from original pen and ink illustrations by Stewart done for *The Puzzling World of Polyhedral Dissections*. You will find instances where Stewart suggests that one see the instruction sheet for a puzzle. So, who do you know that has one of those? For those who are interested in that much detail, I am simultaneously publishing *Puzzles Instructions and Ephemera*, 278 pages of all the instructions Stewart lists in the appendix of this book, plus many more from puzzles made only once or, perhaps, some he forgot about. It also contains earlier serial listings of his designs and most of the sales brochures from 1978 to 1990. Considering the prices being paid for some of his older puzzles, looking at these reminds me of the stock market. All of the other miscellaneous papers he lists in the appendix are also included.

A word of caution is in order regarding the listing of designs: Stewart generally states how many of a design were made, sometimes when and less often from what. Take these statements with a grain of salt. It may say that he has made only one, way back in 1975, or even recently, but he just might have made 10 more last week. This is often the case! With few exceptions, you cannot count on there ever being a unique Stewart Coffin puzzle!

Lastly, Stewart starts off in the introduction saying that he does not expect to add many more to this compendium. Maybe, but he has stopped and started designing and making puzzles more times one of my closest friends has stopped and started smoking! Designing and making puzzles just might be a tougher habit to kick. In fact, after he wrote this, he told me that he and Mary had just made a trip to Lincoln to buy some more wood.

John Rausch
Oregonia, Ohio
July 2003

INTRODUCTION

This is a color edition of a revised and expanded edition of my compendium of puzzle designs first published in 2000. Fifteen copies of a preliminary version were hastily put together for distribution at the Los Angeles International Puzzle Party (IPP-20), and ten more were printed and distributed later that year. Oh well, it never was expected to make the New York Times Best Seller List.

The main reason for this revised edition is to bring things up to date, since the earlier one stopped at #167 in early 2000. This one goes to #190. I do not expect there to be many more to add after that, if any. This is not as ominous as it might sound. It's just that I am overwhelmed with so many other writing and publishing projects, all of which occupy time and office space, I must set priorities. I have already discarded most of my special woodworking jigs and fixtures. Besides making much needed room, it is also nice having less dust in the house.

Another reason for this edition is to provide much more mechanical detail. For many years I saved at least one shop model of each design for reference in case I might want to make more later. Up until 1992, my various publications gave sufficient information for making most of them, but after that the detailed drawings decline in both availability and quality. Recently I have begun selling off many of my shop models, but before doing so I endeavor to get at least the essentials of the design down on paper. I have included many more of those plans in this edition. This is by no means a shop manual, but I do try to at least fill in some of the gaps for those enterprising woodworkers who might want to make reproductions. Of course, many puzzle collectors now have more of my puzzle productions than I have, and I maintain records of all this so I know where most of them are. If my photos or drawings are not clear enough, many collectors are probably willing to loan puzzles from their collections for use as mechanical prototypes.

The first part of this publication contains some background information and commentary on my puzzle craft not included in any of my previous publications. The second part is essentially a chronological listing and descriptions of my AP-ART creations starting at the beginning in 1968. The appendices contain supplementary material. This revised edition contains a few corrections and much new material.

Thanks to Andre van Kammen for his amazing Puzzle Solver 3D program, without which many of the newer combinatorial treasures could never have been discovered.

As already indicated, this is by no means a how-to-do-it manual. Even so, the descriptions given here are probably sufficient for a skilled woodworker to be able to duplicate many of the designs, but only if used in conjunction with the three books of mine that are listed in Part One. Furthermore, this assumes that you start with the simpler designs and work through them progressively to the more complicated ones. That is the way I did it.

It is not necessary to ask my permission to manufacture and sell any of the designs listed here, but I do appreciate being kept informed. I encourage others to become involved in this rewarding and fascinating craft. Unless otherwise indicated, all

of these designs are my own creations. Yet you might say that is only partly true, for they are all based on ideas that have evolved over centuries, their origins fading away into the dim and distant past. As far as I am concerned, they can all be regarded as in the public domain.

PART 1 — BACKGROUND AND COMMENTARY

How It All Began

The spring of 1968 found me busily engaged in the design and manufacture of fiberglass canoes, kayaks, and related equipment, which I had been doing since 1961 after quitting electrical engineering. I was finding the noxious fumes of the fiberglass resins increasingly unpleasant. One fateful day, recalling an illustration I had seen in the marvelous book *Mathematical Snapshots* by Hugo Steinhaus, which my father had given to me way back in 1950, I started playing around with a cluster of 12 triangular sticks. I have always been keenly interested in mathematical and geometrical recreations. This soon led to a variation with notched hexagonal rods that made an intriguing interlocking assembly, **Hectix** (#25).

Back then I was much more adept with fiberglass resins rather than woodworking, so I decided to cast a few of these novelties in epoxy. By the way, the original pattern for molding these pieces was machined accurately from steel by our neighbor, Fred Wilfert, an expert machinist. Our three daughters, then ages 6, 7, and 9, took an interest, especially Abbie, the oldest. Evidently she took one of these novelties to school one day to show her friends, and somehow it also came to the attention of the Town of Lincoln children's librarian Heddie Kent. That led in turn, through a complicated series of connections now forgotten, to my being put in touch with a man in the neighboring town of Concord, Thomas Atwater, whose unusual profession was as business agent for puzzle and game inventors.

Soon, through the efforts of my newfound business agent, 3M Company indicated an interest in adding my **Hectix** to the new line of puzzles in their stationery division, and a contract was drawn up for them to be manufactured in injection molded styrene. On the strength of this, and especially the generous advance royalty, I decided to liquidate my stinky fiberglass boat business and embark on this new enterprise of inventing geometrical recreations.

The Cast Epoxy And Plastic Phase

I spent most of 1970 experimenting with other geometrical models and casting them in epoxy. Some of these are described and illustrated later in this publication. My agent had almost no success in licensing any of them, and in looking back at them now I am struck by how poorly conceived most of them really were. One exception was my **Snowflake** (#3) puzzle, which had limited success. A version of it was cast in polyester resin (with badly misshapen pieces) by the Sam Span Company. It came with a molded styrene base and 10-page instruction booklet. About 500 of these were sold by the Museum of Modern Art in New York. The only other exceptions were my **Frantix** (#9-A) and the Geo-Logic series, both of which are described in Part 2.

An amusing situation occurred in the summer of 1970. The **Hectix** Puzzle was being manufactured by Nylon Products in nearby Clinton, Mass. The individual pieces were spewing out of their high speed injection molding machines by the tens of thousands, but then they had to be assembled, and doing this

with union chemical workers proved to be not only slow but very expensive. An emergency meeting was called in Clinton. After much head scratching, I told them to ship all parts to my plant in Lincoln and we would assemble them for 4 cents each. Unknown to them, my "plant" was to consist of benches set up on our lawn, with our three children doing the assembly. I paid them 2 cents per puzzle and pocketed the difference. Soon some of their neighborhood playmates also got in on this bonanza. Some of them assembled about 100 units per hour. Abbie, then age 10, was once clocked at 11 seconds. We assembled 20,000 puzzles in about two weeks until our contract sadly came to an end. I don't know where they were assembled after that.

There is an interesting sequel to this story. I noticed that some of our better assemblers, Abbie especially, were after a while doing the assembly more by feel without even looking. Later that year we were invited to do a puzzle program on the Tom Colton Show, Channel 22, West Springfield. For the finale of our half-hour show, Abbie was to assemble the **Hectix** blindfolded. This, by the way, was back when such shows were live, not tape recorded as they are these days. So we practiced until she could do it consistently in one minute. On the actual show we allowed two minutes with our fingers crossed, but she came through with time to spare. I wish now that we had a recording.

I am sometimes asked if I have patented any of my designs. I do not think that puzzle patents are a very good idea, and the following experience may help to explain why. I hold two puzzle patents, and the only reason for this is that they were licensed for mass production, and the manufacturer insisted on the patents (and paid for them). They were drawn up by patent lawyers and written in such convoluted language that I hardly recognized my own designs. (It was explained to me that this was done deliberately, but don't ask me why!) After the **Hectix** puzzle had been on the market for a while, I learned through my agent that we were being threatened with a lawsuit for patent infringement. I had already conducted my own patent search, and on the basis of that we concluded that the patent in question was probably of Sanson, 1968—a more complicated assembly of 24 notched hexagonal rods. After we prepared all sorts of arguments why my **Hectix** was different, we learned that the threat was instead coming from a professor of architecture whose patent on structural members did not even mention puzzles. I was told that this was common practice among patent attorneys just fishing for a settlement, and we ignored it. Ironically, later I discovered that the basic idea for the **Hectix** puzzle had been discovered independently a few years earlier by Bill Cutler, but unfortunately for him he never carried it through to successful production.

Incidentally, when my **Hectix** design was later copied and manufactured by other puzzle companies without permission, I asked 3M Company if they intended to enforce our patent. I was told that this was almost never done because of the cost of litigation, which could run as high as half a million dollars. It seems that only the lawyers come out ahead in this game.

By late 1970, it was becoming clear that the only sure way to earn a living in this business was to start making and selling my own products. I wasted much effort trying to find some practical way to cast the pieces in epoxy. When I finally came to the realization that this was a bad idea, I switched to wood-working.

The Sculptural Art That Comes Apart

In the fall of 1970, I had the good fortune to be invited to participate in an arts and crafts festival at the DeCordova Museum, located nearby in my hometown of Lincoln, Mass. It was here that the term “AP-ART” originated. It seems that one of the other exhibitors at the show took his work very seriously. When he found my children and me, purveyors of wooden “toys” setting up right next to his exhibit of abstract sculpture, he displayed his strong displeasure and asked, “What’s that!” That was back in the days when Op Art and Pop Art were in vogue, so I jokingly replied “AP-ART.” He found it not very funny and objected to our being even in the same room with him. So, to our good fortune, we were banished to the more folksy and friendly outdoor craft area, which happily introduced us to other craftsmen and marked the beginning of our craft fair years. That memorable phase of our family enterprise, all too brief as it was, kept us all entertained and was a valuable experience for our three little helpers. It also brought us in direct contact with the public and served as a valuable learning experience for me.

By early 1971 I was beginning to make and sell my unique line of geometrical woodcraft products. Describing to others what I did for work always was a problem. If I said that I created puzzles, they would usually ask “jigsaw or crossword?” I soon learned not to follow that up with any attempt to describe them as three-dimensional puzzles because I dreaded being asked almost invariably, “Oh, do you make Rubik’s Cube?” It hurt every time I was asked that. (And I still am asked!) Consequently, for a long time I deliberately avoided the use of the word “puzzle” in describing my work. Never again will I use it in the title of a book. For a while I even tried to avoid using it in the text of this publication, awkward as that was. Hence the renewed emphasis on my fanciful but fitting slogan “AP-ART, the sculptural art that comes apart.”

The Craft Fair Years

From 1971 to 1975, most of my sales were at craft fairs. Usually our whole family was involved—my wife Jane and our three little girls, Abbie, Tammy, and Margie. The most important of these was the annual American Crafts Council fair, first in Bennington and later Rhinebeck, which was both wholesale and retail. Soon I had more business that I could possibly handle and was turning customers away. The main reason for this was that practically no one else was in this line of woodcraft, and certainly not as a full-time business. Even many years later this was still the case.

The wholesale business was more profitable of course because of the volume, but I much preferred the retail sales because it brought us into direct contact with the public. I recall many amusing incidents. One passer-by, probably a psychiatrist, stared at our large display of perplexing polyhedral dissections and asked, “Did you have an unhappy childhood?” Later that

was used as the name for one of my more puzzling creations. More than one customer asked if I had a puzzle that would drive someone completely out of their mind. I assumed they were targeting their spouse or other close relative, and I would remark to Jane that perhaps we should check our liability insurance.

We had one act that we used over and over. Usually the **Jupiter (#7)** puzzle served as the centerpiece of our display. It looks a lot more confusing than it really is. If you toss it up with a slight spin it flies apart into a jumbled heap of 12 pieces. I would remark that anyone who could put it back together could have it. No adults would ever try. In the meantime, our youngest, Margie, would be planted in the gathering crowd and would work her way to the front. You can guess the rest. The audience loved it.

Most of our retail sales at craft fairs were to customers who were buying gifts for someone else, and I knew that they were nearly always for adults. I always regretted that so few were for children, but the cost was a factor. We did have one low priced novelty that we called the **Buttonhole (#45)** Puzzle. Not my idea but an old favorite, it is just a stick and loop of cord that you attach to someone’s clothing like a price tag. We made them from wood scrap using about 50 different kinds of exotic woods. My kids sold them for 25 cents each, often after attaching them to the victim’s clothing. Sometimes we would be told years later that they were still on!

Buttons And Beads

In an attempt to come up with a low cost product that children could afford, in 1972 I turned my attention to topological puzzles, which typically use beads and cord with no close tolerances required. One of these was my **Sleeper-Stopper (#43)** puzzle. Since I could not find any supply of high quality wooden beads, I decided to make my own. The machine that I devised to make them was basically a rapidly rotating 8-inch abrasive disk at the bottom of a round drum. Three-quarter-inch rosewood cubes with holes already drilled were loaded into it 100 at a time, and the abrasive was progressed from coarse to fine, and finally to buffing with wax. They came out rounded and shining like gemstones.

Soon customers began asking if they could buy just the beads. I made a larger bead mill with 12-inch disk and we turned them out by the thousands in various exotic hardwoods. The demand was phenomenal. At craft fairs we filled large wooden bowls with beads. People couldn’t resist the urge to run their fingers through them, much the same way you play with sand at the beach. I devised a semi-automatic machine for drilling the holes, and turned over much of the operation to my kids. We added buttons to the line, and then pendants and earrings made with colorful laminated woods.

By 1975 we were filling so many orders for these that there was little time for making wooden puzzles. I began thinking that maybe it was time to return to more creative endeavors. But then an unemployed mechanical engineer named Laurie Grob who lived nearby, and whose wife was one of our button customers, came up with the idea of a key ring with a fancy wooden part that could be made using my bead machine. He

had also located a company that was interested in purchasing them in very large quantity. We made an even larger mill using my wife's old washing machine, and we spent all of 1976 turning these out by the tens of thousands in various fancy woods. When that contract finally ran out, Laurie bought out my half of the business and moved to New Hampshire, where he improved the whole process and started a successful button business. Last I knew, he was still at it. I happily returned to making wooden puzzles.

Museum Exhibits

Over the years, my associates and I have participated in a number of puzzle exhibits where the theme was just to display the various objects to be viewed by the public, usually in glass cases. The obvious objection to this is that mechanical puzzles are by definition designed to be manipulated. Take that away and what is left? Most polyhedral dissection puzzles do have the feature of being attractive to look at when assembled, especially when made with colorful exotic woods finely finished. But that can be both an advantage and disadvantage. I soon discovered that some customers were acquiring mine just to look at, without ever taking them apart. Sometimes I would even get a call from one of them exclaiming that some unruly child had taken one apart, and would I please send directions for putting it back together.

I will admit that when I first started making polyhedral dissection models, I too was fascinated by the way that geometrical solids fit together in space and the interesting shapes that resulted. Many of my early designs were little more than that—sculptural art that came apart. Later on, many other novel design aspects came into play, none of which could be appreciated or enjoyed by just admiring the assembled puzzle. I would often use plain hardwoods rather than colorful exotic woods in my work so that the sculptural features, which were really incidental, would detract less from all the other more important creative aspects that went into the design.

Again we come back to the limitations of puzzle exhibits. Some of us have tried hands-on puzzle shows with limited success. For the general public, the puzzles need to be very simple ones. Even so, you can soon end up with a pile of puzzle pieces unless there are many helpful hands around to reassemble them. Most museums don't have that kind of help available.

Books

Given the limitations of puzzle exhibits or museum collections, and the impossibility of producing enough to supply the public demand, perhaps the next best alternative is to be found in illustrating and publishing. Such books are now coming out like never before.

My first book, *Puzzle Craft*, was begun in 1974 as a newsletter of limited circulation having to do with mechanical puzzles in general, especially those that could be made in the classroom or workshop. In 1978, the various issues were assembled into a booklet. Later, more chapters were added, and it was published as a book of sorts. A revised and improved edition was published in 1985. Minor revisions continued to be made until its final printing in November 1991. In all, about 2500 copies of *Puzzle Craft* 1985 were printed. In 1986, Oxford University

Press became interested in publishing something along the lines of my *Puzzle Craft* to be included in their Recreations in Mathematics series. This involved a whole new approach and complete rewrite with much more material included. That book, *The Puzzling World of Polyhedral Dissections*, came out in hardcover in 1990 and in paperback in 1991. About 1800 of the hardcover were printed, and probably a few thousand of the paperback (I was never sure). They both sold out within months, never to be reprinted by Oxford, for reasons that to this day remain a complete mystery.

Since I continued to receive requests for my old *Puzzle Craft* 1985, and since there was much overlap between it and the Oxford book, in 1992 I came out with a completely new edition of *Puzzle Craft* in which the emphasis is on woodworking, whereas the Oxford book was more to do with geometrical recreations. As of 2000, *Puzzle Craft* 1992 and the other two books mentioned above are all available on CD-ROM. For more information on this visit the *Puzzle World* web site at www.JohnRausch.com/PuzzleWorld.

In addition to the above, I should mention some of the other related printed matter that I disseminate:

From the start in 1968, I have kept records of my designs on file. Since names can be confusing (especially mine!), in 1970 I started numbering them as well. In 1985, I adopted a revised numbering system that I still use. In 1993, thanks to this amazing computer, I began making this list available as Serial listing of AP-ART puzzles produced and sold. It is updated yearly or sometimes even monthly. This present publication can be thought of as an expanded and much more detailed version of that list.

My serial listings of designs described above is approximately chronological. However, since I have often used a letter suffix for a new modification of a previous design, therein is a departure from chronological. As of January 1998, I revised my numbering of designs to make them strictly chronological.

Many of my designs are accompanied by an explanatory printed sheet that may also occasionally include the solution. Since 1993, an up-to-date listing of all these has been available as *Serial List of AP-ART Instructions, Descriptions, and Other Printed Matter*. The most recent version of this list is in the Appendix.

PART 2 — AP-ART DESIGNS

Several puzzles predate the current serially numbered listing of designs. For historical completeness, a few of them are worth mentioning.

The first puzzles that I made were of the common jigsaw variety, when I was barely old enough to dissect scraps of plywood with a coping saw. From earliest childhood, I had a fascination for all things mechanical. My parents were very tolerant of my urge to take apart old appliances and machinery (later radios and electronic equipment), and soon I acquired a knack at repairing them. My father was an early pioneer in both scientific plant photography and pictorial nature photography, but he soon realized the futility of encouraging me to follow in his accomplished footsteps. He plied me with books and magazines on all the things I loved—mechanical, scientific, and mathematical. There was never the slightest question but that I would study engineering in college.

As a carry-over from model airplane days, I had some solid blocks of balsa wood. With these, I was inspired to create some three-dimensional jigsaw puzzles. These probably date from around 1946, since you could not get much balsa wood during World War II.

In that wonderful 1950 book already mentioned, *Mathematical Snapshots* by Steinhaus, I remember being especially fascinated by the rhombic dodecahedron and its various spatial properties. This must have remained dormant in the back of my mind until reemerging two decades later. That book also described a simple $3 \times 3 \times 3$ cubic dissection called Mikusinski's Cube, which sparked my interest in cubic dissections.

Seven Block is the first original design for which I have any record. It was designed around 1958 while I was working at M. I. T. Lincoln Laboratory. It is a 7-piece $4 \times 4 \times 4$ cubic dissection. I include it so that you can see progress has been made since then. Several of us at the Lab were interested in mathematical recreations, especially fellow electrical engineer Gus O'Brien. (It was he who first introduced me to the simple but intriguing six-piece first stellation of the rhombic dodecahedron.) I created the **Seven Block** and made one for Gus to puzzle over, but he quickly solved it. I made only that one. It is now in a collection in England.

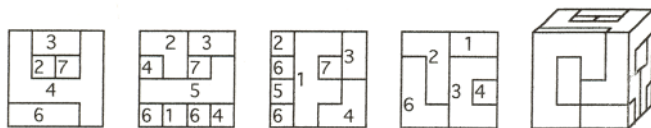

As previously explained, for a while before the woodcraft began, I tinkered with experimental models cast in epoxy. The following were all created between 1968 and 1970.

Spinner, was one of the first, consisting of 6 identically shaped pieces in 3 colors, 2 of each. An injection-molded styrene version of this was later produced by Skor-Mor in their Geo-Logic series as **Tauri**. There was also a 4-color version in which each piece was of 2 halves of different color bonded together, to be assembled in color symmetry. Only about a dozen **Spinners** were cast.



Four-Color Spinner in cast epoxy by Stewart Coffin

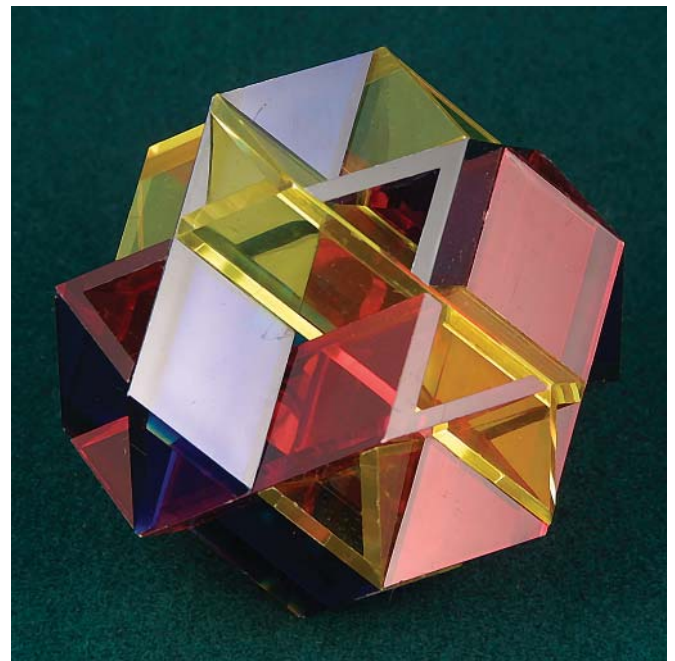

Tauri in styrene by Skor-Mor

The **Z-Puzzle** consisted of 12 nearly identical Z-shaped pieces, likewise cast in multicolor, which assembled to form a truncated rhombic dodecahedron. Only a few of this uninteresting design were cast.

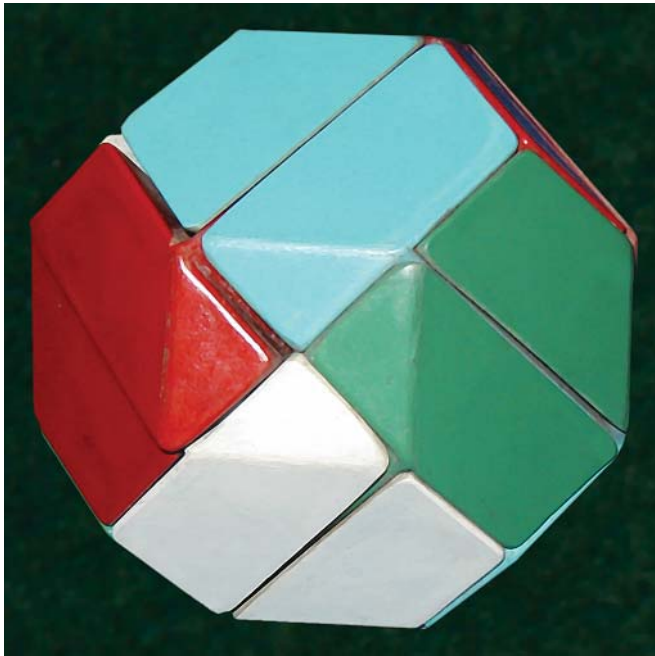

Z-Puzzle in cast epoxy by Stewart Coffin

Prism consisted of 6 identical pieces, cast in 3 colors, which assembled to form 3 intersecting square prisms. This was later the basis for the **Seven Woods** (#42). Only a few were cast.

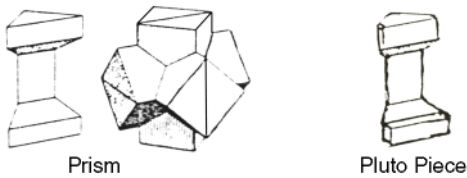

Prism

Pluto Piece



Prism in cast epoxy by Stewart Coffin

Pluto was a slightly more interesting version of Prism, in which each piece had a shoulder at one end, with assembled end faces slightly octagonal rather than square, and only one axis of assembly. Only a few were cast.

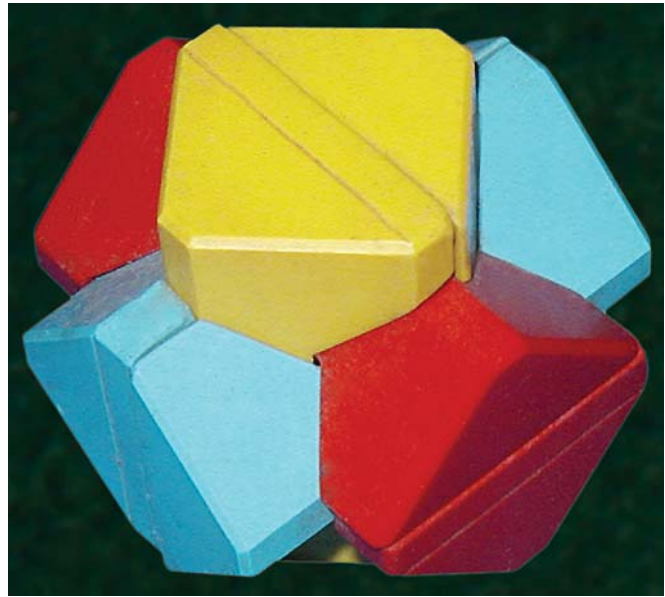

Pluto in cast epoxy by Stewart Coffin

Octo was similar to **Prism** except that each piece was dissected longitudinally, making 12 pieces. It likewise used 4 colors with associated color symmetry problems. It was an exercise in dexterity to assemble. One version had a split piece for easier assembly. The assembled shape suggested an octahedron. Only a few were cast, but a modified version later led to the baffling **Three Pairs** (#27).

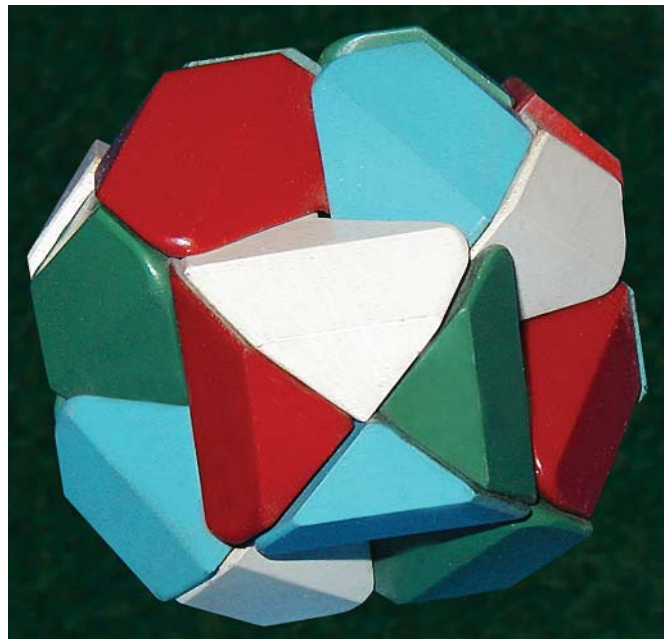

Octo in cast epoxy by Stewart Coffin



Truncated Octo in cast epoxy by Stewart Coffin

Four-Color Cube consisted of 12 cast pieces, 3 of each color, which were to be assembled into a cube with 4 colors on each face. There was also a slightly more interesting version in which the pieces were joined in pairs to make 6 bicolored pieces. Only a few were cast.

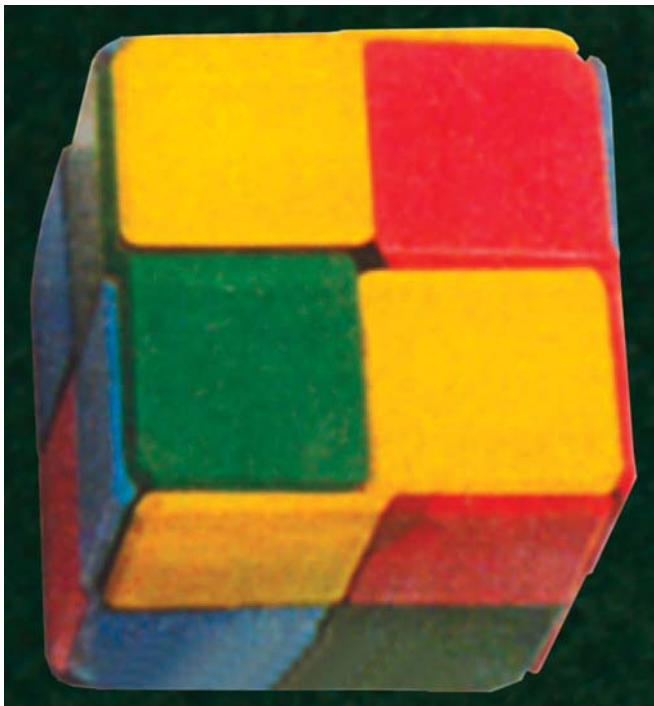
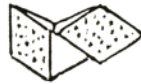

Four-Color Cube in cast epoxy by Stewart Coffin

Four-Color Octahedron was similar to **Four-Color Cube**, also with 12-piece and 6-piece versions. Only a few were cast.

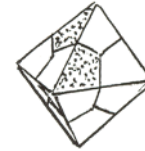

Four-Color Octahedron in cast epoxy by Stewart Coffin

Tetrahedron was similar in principle to **Prism** except that the assembled shape was tetrahedral. It later became the basis for the injection-molded **Cetus**, produced by Skor-Mor in their Geo-Logic series.

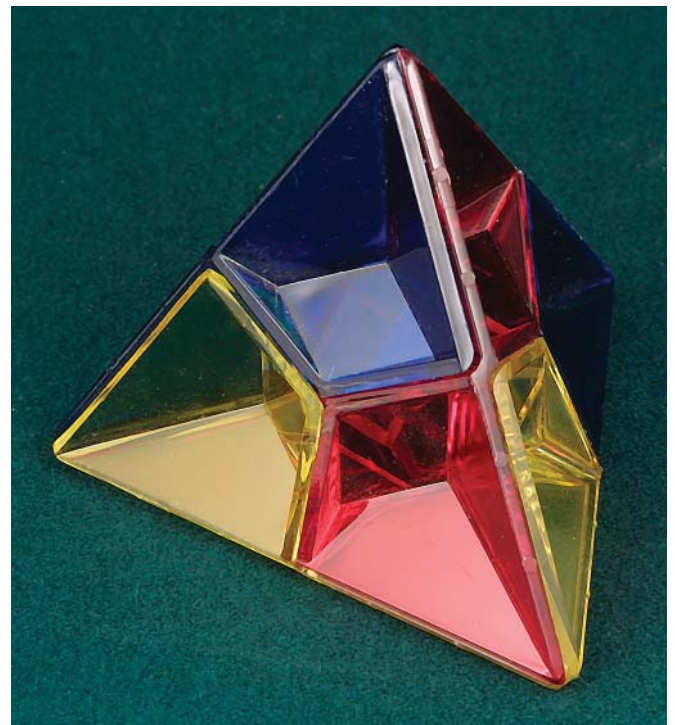

Cetus in styrene by Skor-Mor

There were many other experimental few-of-a-kind models cast during this phase and on into 1971, mostly not recorded. Some of them became the models for other “puzzles” in the Skor-Mor Geo-Logic series, such as **Nova**, **Spirus**, and **Uni**. There was one, **Double Star**, that could be assembled inside out to form two different geometrical solids, but the Skor-Mor version was so misshapen as to be nearly useless.

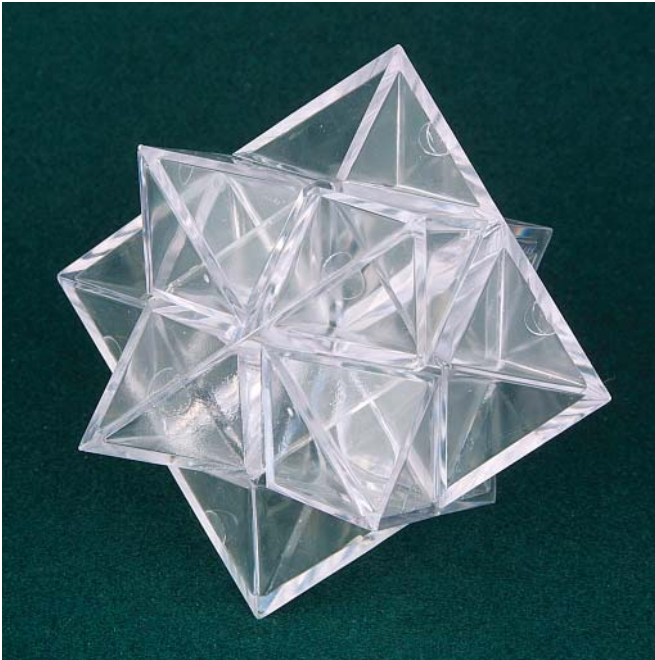

Double Star assembled in diagonal star configuration in styrene by Skor-Mor

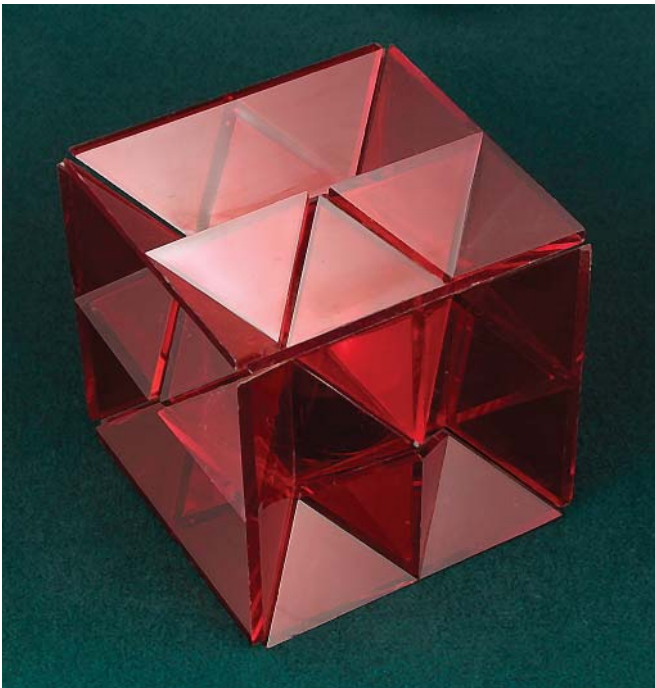

Double Star assembled in cube configuration in styrene by Skor-Mor

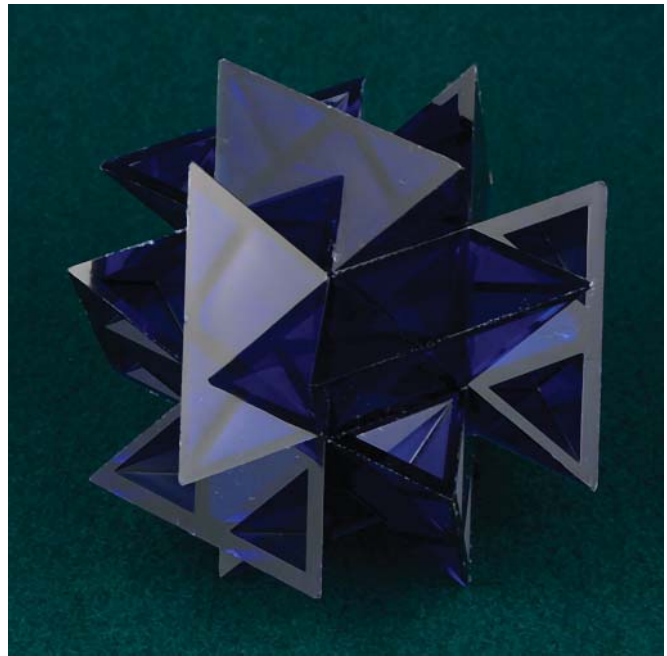

Spirus in styrene by Skor-Mor

One of the problems with the Skor-Mor series was that, in order to economize on mold costs, the manufacturer insisted on only puzzles with six identical pieces. In that way, a multi-cavity mold could produce several different puzzles at the same time. There is only so much you can do with six identical pieces. Another problem was that the pieces had to be cored out, meaning that they consisted entirely of thin walls in order to cool faster in the mold and speed up the mold cycle. I wish now that they had never been made.

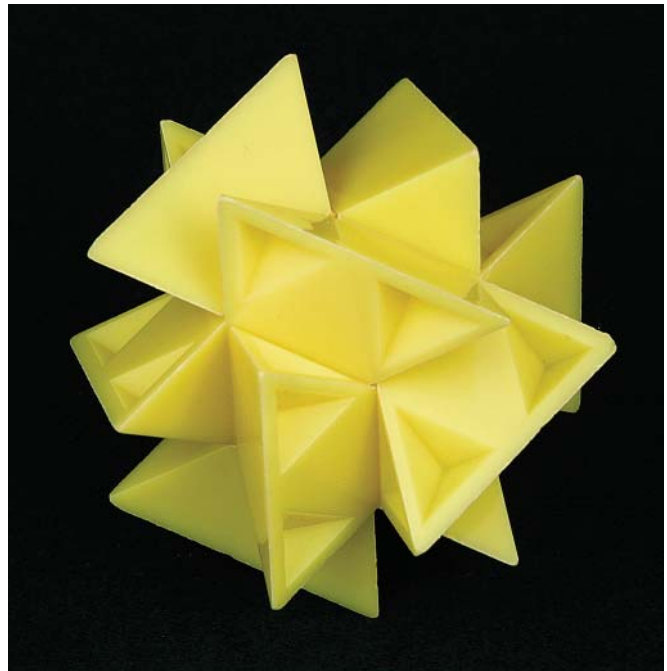

Spirus in styrene by Skor-Mor



Uni & Aries by Skor-Mor

The **Hectix (#25)** puzzle, on the other hand, was solid .75-inch hexagonal. This was achieved by including a blowing agent in the styrene and a slower mold cycle, increasing the cost. A lot of this technology was new to the molder, and there were problems with burned or misshapen pieces, some of which were never completely corrected. The discoloration from heat was especially bad because of the ugly off-white color that the manufacturer chose. Our Agreement called for it to be made in four contrasting colors—red, yellow, green, and blue—but they never did it that way. I wish now that it had never been made in plastic. A wooden version would have been better.

As I mentioned in the Background and Commentary section, for a while in 1970 I even experimented with setting up a production line myself casting puzzle pieces in epoxy. In looking back now, that seems so totally impractical that I can only wonder what I could have been thinking. One problem never overcome was that the RTV rubber molds, which were a lot of work to make, deteriorated rapidly after only a few cycles. The whole process was slow and messy, and most important, the finished product was not very attractive. And so I switched to wood, and the remainder of this publication is devoted to that phase of my work.



Hectix (#25) in cast epoxy by Stewart Coffin

Again simply for the sake of being complete, before proceeding to the numerical listing, I will briefly describe just a few of the early attempts in wood that never made it into production.

OCC-Wood consists of 3 plywood pieces in the shapes of O-C-C, plus 2 small cubic blocks. They assemble easily into a familiar burr shape with the blocks inside, and the problem is to have the blocks fall into position to permit disassembly. Without the cubic blocks, it is a familiar old novelty published in many books. Only a few were made around 1973.

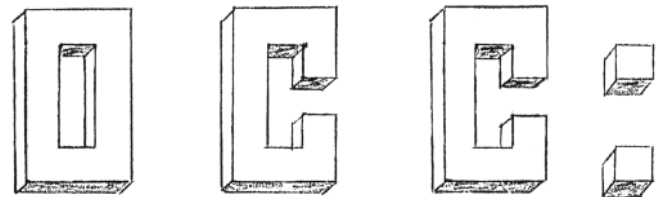

Rec-Tangle also consists of 3 pieces in the O-C-C shape as above, but this time of glued up pieces, with a hole in one piece and a dowel loose inside. The first step of disassembly is to shake the dowel into the hole, which can be made as easy or hard as one wishes by the size and shape of the dowel and hole. Four more steps are required to disassemble. There is also a modified version in which the O piece is split into 2 burr-like pieces. Only a few were made around 1973.

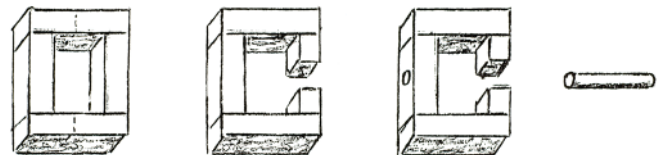

Wunder Bar consists of 6 pieces that fit together to form a cubic lattice. There are 4 types of pieces—W, X, Y, Y, Z, Z. Each piece is made up of three 1×1×5 sticks joined together. W and X are mirror image, likewise Y and Z. The diagram shows the design. There are 4 distinct mechanical solutions, but by using multi-colored woods and requiring color symmetry, the number of solutions can be reduced. Only a few were made in 1973.

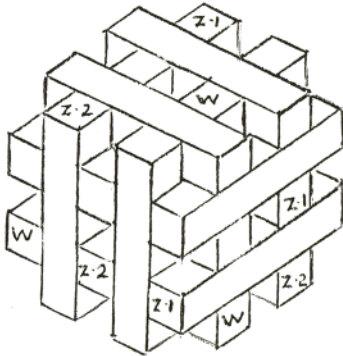

Interlocking Checkerboard consists of 8 pieces that fit together 2 different ways to form (guess what!) an interlocking checkerboard (1973). Probably none were made.

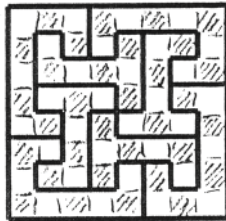

Cube Brute consists of 24 identical burr pieces that interlock to form a symmetrical cubic-shaped assembly. A 16-piece square assembly is also possible. A couple sets were made in 1973. Pentangle came up with this independently around the same time, sold as their Woodchuck Puzzle. I also proposed a set to be called **TWIS-T**, in which 16 pieces are bonded together into 8 T-shaped pairs. In yet another variation, **RUFTY**, the remaining 8 pieces are also bonded together in-line. Multicolored pieces with color symmetry solutions were also proposed. Possibly a few of each were made, all in 1973.

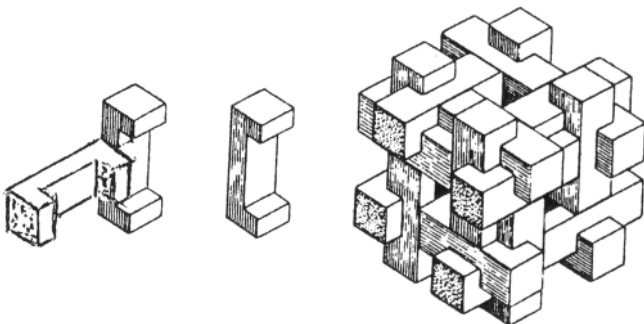

Mosaic is an 8-piece dissection of a 4×4×4 cube, designed in 1979. I must have made at least one, but have no record. The one known solution is shown here, but perhaps there are others. It is almost serially interlocking. An improved version became **Convolution** (#30).

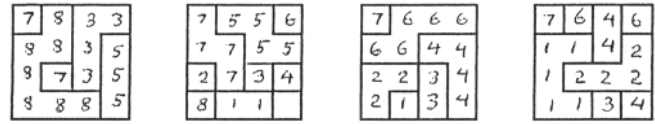

In the same vein as the above, here is one with no name that appears in my notes for 1979. It is a six-piece 4×4×3 dissection with the capability of being made with eighteen 1×1×2 blocks and twelve 1×1×1 blocks of colorful woods such that symmetrical patterns appear on all faces. It is non-interlocking, so a box or tray might be used to retain it. Must have made one.

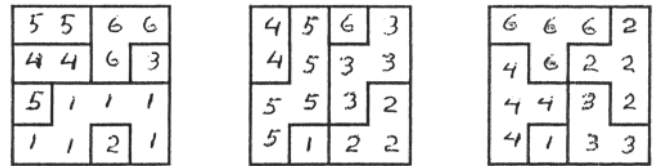

Triful was designed in 1973 for production in plastic, and a few models made of colored wood, but it was never produced. It consisted essentially of 12 triangular sticks with end blocks added, in 4 colors, 3 of each. Four pieces, one of each color, were split in two to permit assembly. Then a wooden version was designed around 1975 that used 4 sliding key pieces instead of split pieces, but only one or two were made. Much later this design was resurrected to become the basis for **Isosceles** (#101) and **Iso-Prism** (#101-A). See also **Notched Rhombic Sticks** in *The Puzzling World of Polyhedral Dissections*.

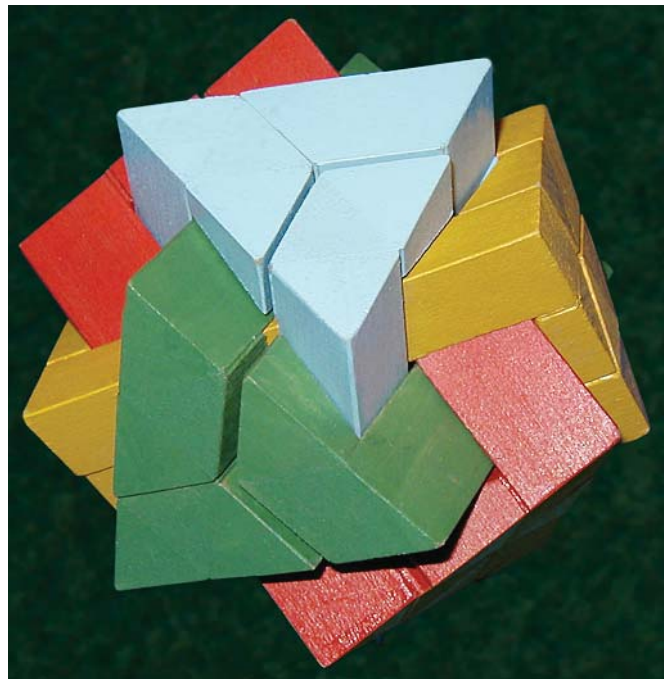

Triful in painted wood by Stewart Coffin

As some of the above entries indicate, I have ransacked my records to include everything in this comprehensive listing of AP-ART, no matter how mundane or obscure. There were many others that were never recorded and are now lost and forgotten. A few more may turn up from time to time, and if so I will add them later on.

I am not including in this publication any of my admittedly feeble attempts at inventing games, such as **Arc-Tic**, and **Hebee-Shebee**, as they do not fit my concept of AP-ART. For the same reason, I omit topological amusements such as **Lamplighter**, **Liberty Bell**, **Bottleneck**, **Sleeper-Stopper**, **Super Sleeper-Stopper**, and **Figure Eight**, most of which are described in *Puzzle Craft 1985*.

Now on to the numbered designs. I have tried to indicate the year designed, published, or first made, when known. The first illustrated brochure I put out was in 1970, and the last in 1990. I have also indicated the approximate number made, but only up to around 1990, after which the quantities decline to the level of a retirement hobby activity.

1 Ortho-Cube

A non-solid semi-symmetrical 12-piece dissection of a $5 \times 5 \times 5$ cube. This early version, which appeared on my first brochure in 1970, was made of $\frac{7}{8}$ -inch square birch stock. About 20 were made in 1970. For more information, see the 1970 instruction sheet, and also description and drawings of **The Cube** (#1-A).

1-A The Cube

An improved and slightly smaller version of the **Ortho-Cube** (#1). Twelve pieces, three kinds, four of each. The building blocks are $1 \times 1 \times 1$ cubes and $1 \times 1 \times 3$ bars, all $\frac{3}{4}$ -inch unit size. Assemble to form a $5 \times 5 \times 5$ cubic assembly with holes in the centers of all six faces. In one of the common production versions, the bars were bubinga, the corner cubes Brazilian rosewood, and the edge cubes satinwood. For more information, see 1971 instruction sheet. Appeared on 1971 brochure. About 100 made, 1971-1972. It was later made by Pentangle with the name **Wokey Hole**.

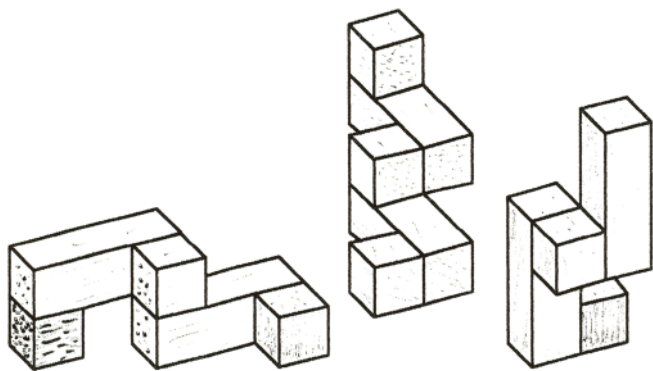

The Cube (#1-A) in cherry, mahogany, maple, rosewood & padauk by Stewart Coffin

2 Pentablock

This is the familiar set of 12 solid pentominoes in a $3 \times 4 \times 5$ box. This early version was made of $\frac{7}{8}$ -inch birch blocks. Appeared on 1970 brochure. About 20 made.

2-A Pentablock

A slightly improved version of **Pentablock** (#2), made of $\frac{3}{4}$ -inch hardwood stock in a Plexiglas box. Appeared on 1975 brochure. About 10 made.

2-B Pentacube

An improved version of **Pentablock** (#2-A), same size, but made of 12 different fancy woods colorfully combined in the given solution, shown. The box was blue mahoe. Appeared on 1977 brochure. About 20 made. More information on this popular recreation may be found in *The Puzzling World of Polyhedral Dissections* and numerous other books.

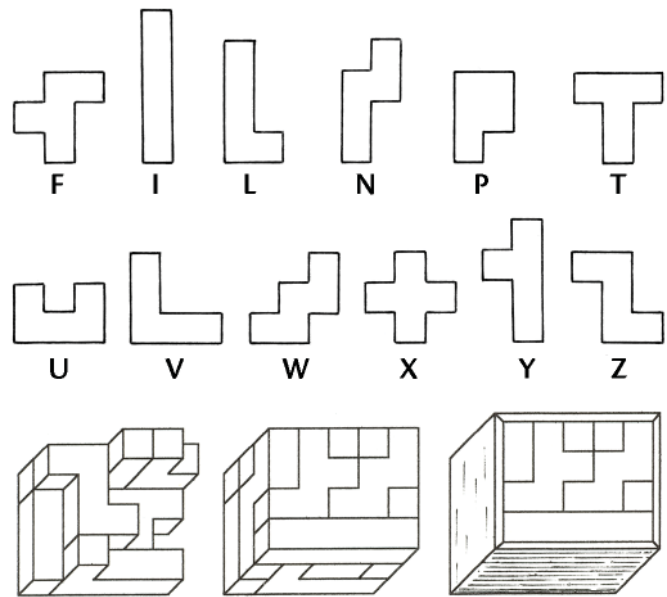

Pentacube (#2-B) by Stewart Coffin

3 Snowflake

The ten puzzle pieces of **Snowflake** represent all the ways that three or four hexagonal blocks can be joined together, requiring 37 blocks. They came with a hexagonal tray that would accommodate either of two symmetrical solutions, referred to as the “Snowflake” and “Hex” patterns. Also included was an instruction booklet showing numerous other problem shapes. For more information, see *Puzzle Craft 1985*, *Puzzle Craft 1992* and *The Puzzling World of Polyhedral Dissections*. The first version, which appeared on my 1970 brochure, was of cast thermo-setting resin. About 50 made.

The next version was one made by Span-Atwater of cast polyester resin. They made about 500, 1972-1973, most of which were sold by the Museum of Modern Art. It came with an improved 10-page instruction booklet showing 49 problem shapes, as did all subsequent versions. The tray was molded styrene.

A wooden version is mentioned on my 1977 brochure, but I don't think many were made.

The next version had cast Hydrastone pieces and a surplus styrene tray. Appeared on 1978, 1979, 1981, 1984, and 1985 brochures. About 100 made.

The next version was in fancy wood with plywood base and cover. About 10 made in 1986.

The next version was in thin birch plywood cut by Jim Ayer with a water jet with the same styrene base. Appeared on 1990 brochure. About 30 made.

The most recent version was in plastic foam, made and sold by Binary Arts around 1993. All of these versions were the same scale— $\frac{3}{4}$ -inch hexagons.

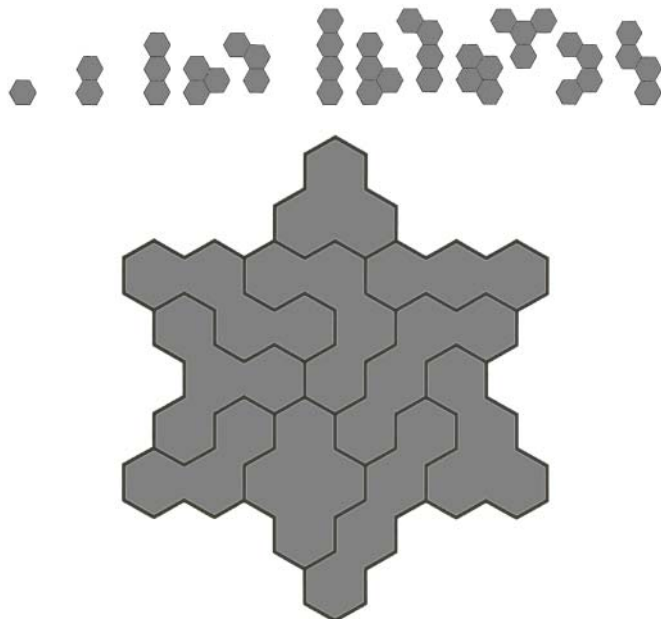

Snowflake (#3) in padauk with benge tray and lid by Stewart Coffin

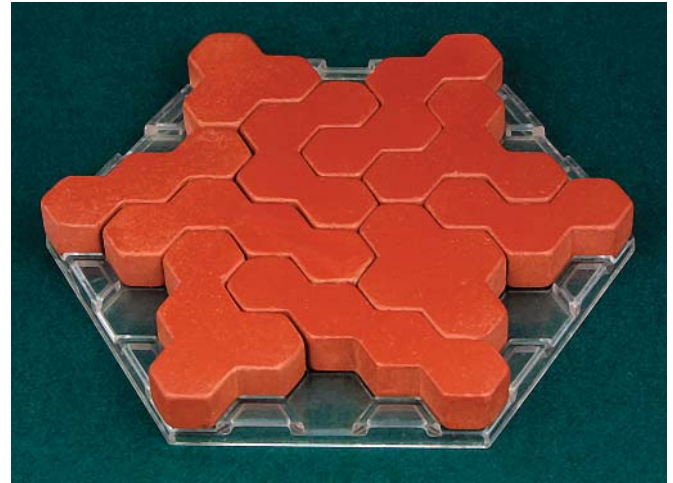

Snowflake (#3) in cast Hydrastone with styrene tray by Stewart Coffin



Snowflake (#3) in cherry and walnut by Walt Hoppe

4 Sirius

The six identical pieces assemble in two mirror image halves of three pieces each to form the familiar first stellated dodecahedron. Not difficult but requires some dexterity. This design has long been in the public domain. The unique feature of this version is that each puzzle piece is made up of three blocks glued together. This reduces the tendency of the sharp tips to break off because of the different direction of the grain. Appeared on 1971 brochure. About 100 made.

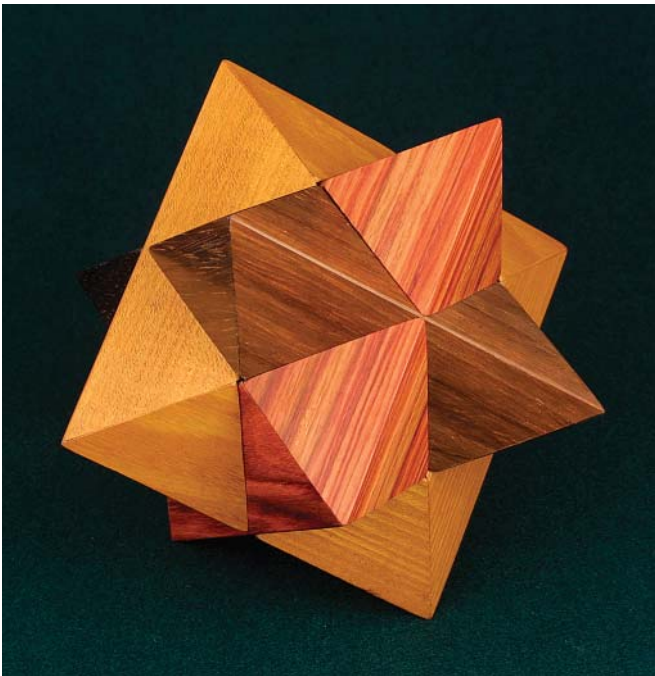
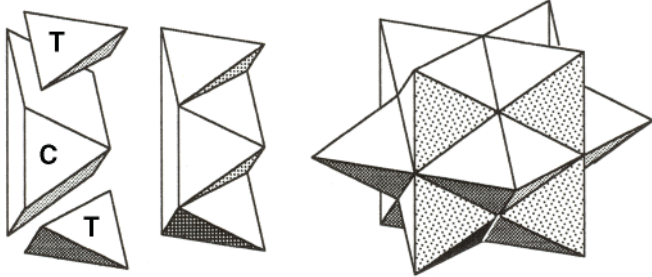

Sirius (#4) by Stewart Coffin

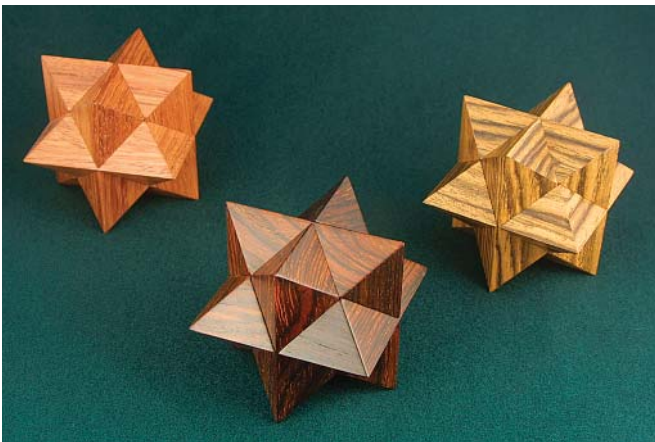

Sirius (#4) in bubinga, cocobolo & oily bocote by Lee Krasnow

4-A The Star

This is an improved version of **Sirius** (#4), 25% larger and in three contrasting colorful woods. Two assemblies with color symmetry are possible. In one, all like colors are mutually parallel, and in the other each of the six sides is one solid color. The stock was 1.25-inch size. Appeared on 1974 and 1975 brochures. About 400 made. For more information see *The Puzzling World of Polyhedral Dissections*.

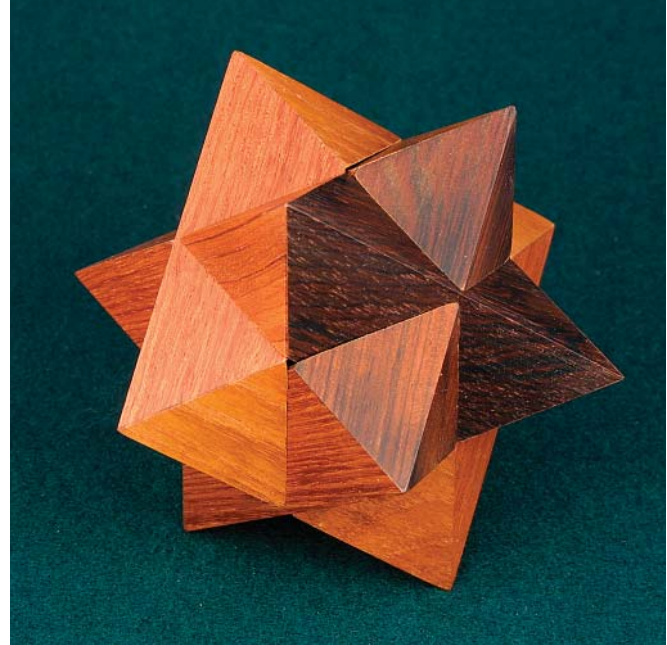

The Star (#4-A) by Stewart Coffin



The Star (#4-A) in Macassar ebony, oily bocote & airy Cambodian rosewood by Lee Krasnow

5 Spider-Slider

Six identically shaped symmetrical puzzle pieces, each one made up of four triangular sticks joined together, assemble by mating two halves of three pieces each to form a polyhedral solid. Made of basswood. The four arms of each piece are stained a different color—red, yellow, green, blue—in all six possible permutations. The object is to assemble in color symmetry. There are four different symmetries possible. My first polyhedral AP-ART in wood. About 20 made in 1970. For more information see *Puzzle Craft 1985* and *The Puzzling World of Polyhedral Dissections*.

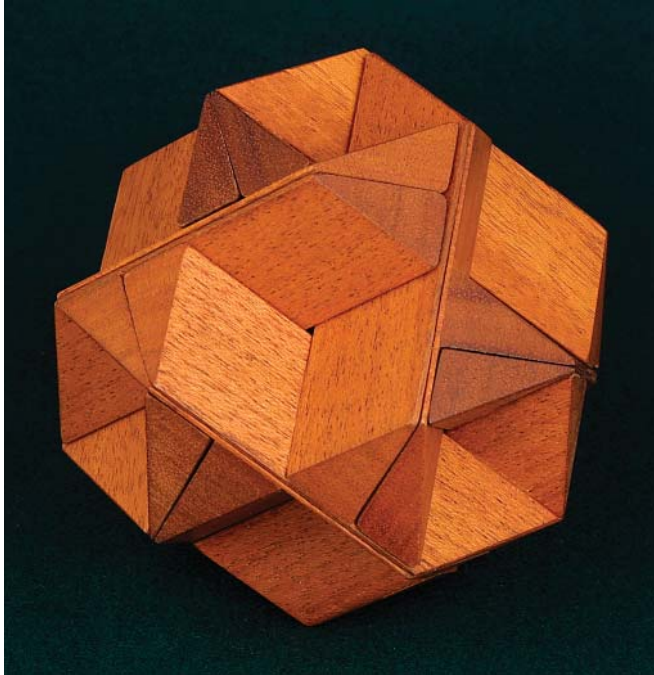

Spider Slider (#5) in mahogany by Stewart Coffin

5 Scorpius

This is an improved version of **Spider-Slider** (#5). Instead of stain, four contrasting fancy woods are used. Appeared on 1971 and 1972 brochures. About 200 made.

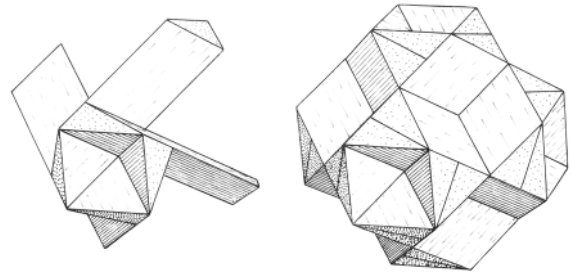

Scorpius (#5) in Tulipwood, Osage Orange Luzon Acle & Rosewood by Stewart Coffin



Scorpius (#5) in black palm, holly, ebony and bleached wenge by Bart Buie

6 Four Corners

Six identically shaped symmetrical pieces assemble by mating two dissimilar halves of three pieces each to form a polyhedral solid intermediate between the first and second stellations of the rhombic dodecahedron. Each puzzle piece is made up of a six-sided center block to each end of which is attached a prism block. The prism blocks are in four contrasting fancy woods, combined in all six possible permutations of dissimilar pairs. The simple object is to assemble such that each *corner* is one kind of wood. See *The Puzzling World of Polyhedral Dissections*, pages 85-86. Appeared on 1971, 1972, 1974, and 1975 brochures. About 200 made.

A version of **Four Corners** in oak and purpleheart was made by Roy Rice and used in the IPP-14 puzzle exchange.

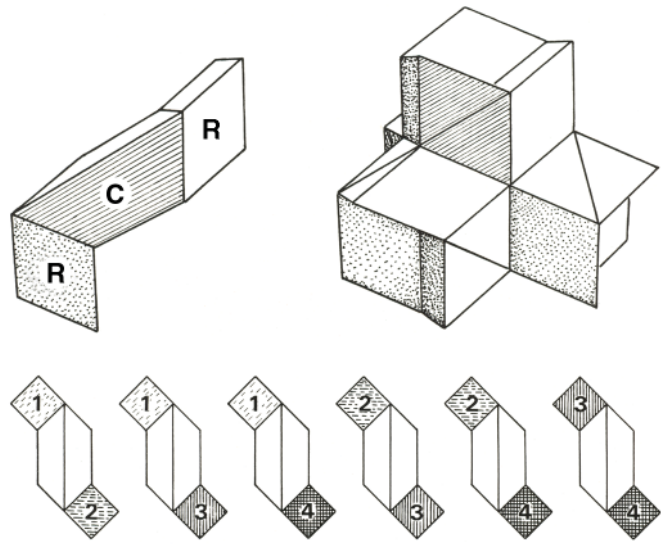

Four Corners (#6) in Brazilian satinwood, canarywood, pau ferro & cardinal by Tom Lensch

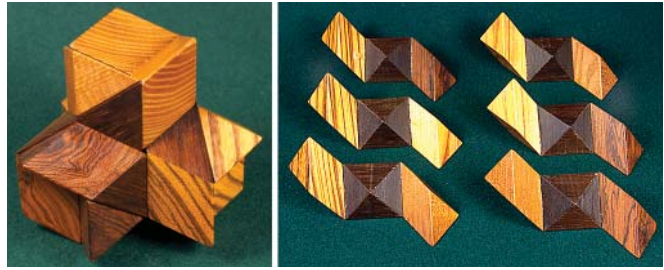

Four Corners by Stewart Coffin

6-A Aries

This was a plastic version of **Four Corners** (#6) made by Skor-Mor for their Geo-Logic series.



Aries (#6-A) in styrene by Skor-Mor

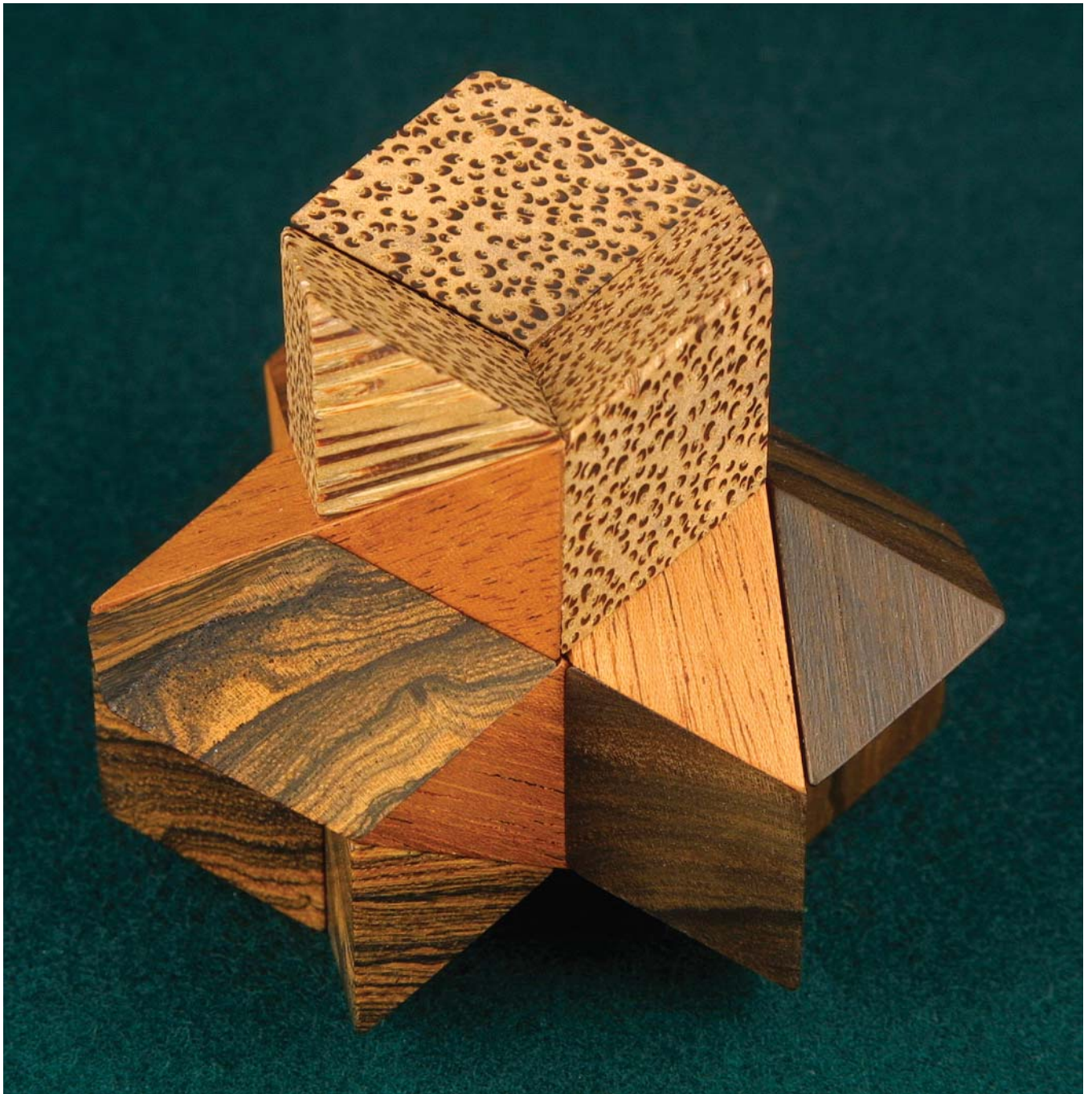

Four Corners (#6) in red palm, pau ferro, bocote, zircote & mahogany by Bart Buie

7 Jupiter

Twelve symmetrical and identically shaped puzzle pieces, each one made up of five triangular sticks joined together, assemble by mating two identical halves of six pieces each to enclose a hollow having the shape of a triacontahedron. I call the resulting solid a castellated triacontahedron. Six contrasting fancy woods are used for the arms, combined such that the puzzle can be assembled with all like woods mutually parallel. Four other less obvious symmetrical solutions are also possible. For many years my most popular AP-ART creation, and used for the centerpiece for our display at craft shows. Appeared on 1971, 1972, 1974, 1975, and 1977 brochures. About 400 made. For more information, see *Puzzle Craft 1985* and *The Puzzling World of Polyhedral Dissections*.

The **Jupiter** would be one of the more difficult puzzles for the casual woodworker to make. The difficulty is in the gluing jig. The form for mine was made by an expert machinist using a Bridgeport milling machine with rotary table. Few home hobbyists will care to go to all that trouble and expense. One alternative is to use one of the pieces from one of my **Jupiter** puzzles and cast a gluing jig from it in plaster of Paris. Although I had 24 of these jigs at one time, several of them are now in the hands of other puzzle makers.

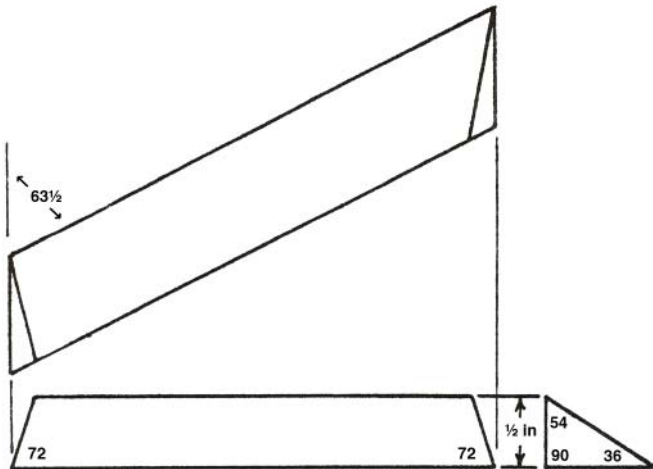

| A | | C | | E |
|---|---|---|---|---|
| 1 | 2 | 3 | 4 | 5 |
| 1 | 4 | 6 | 2 | 5 |
| 1 | 2 | 5 | 6 | 3 |
| 1 | 6 | 4 | 2 | 3 |
| 2 | 6 | 5 | 3 | 4 |
| 1 | 4 | 5 | 3 | 6 |
| 1 | 5 | 4 | 3 | 2 |
| 1 | 5 | 2 | 6 | 4 |
| 1 | 3 | 6 | 5 | 2 |
| 1 | 3 | 2 | 4 | 6 |
| 2 | 4 | 3 | 5 | 6 |
| 1 | 6 | 3 | 5 | 4 |

This table shows how dissimilar woods are combined in the twelve puzzle pieces. The first piece would have woods 1, 2, 3, 4 and 5 on arms A, B, C, D and E, etc.

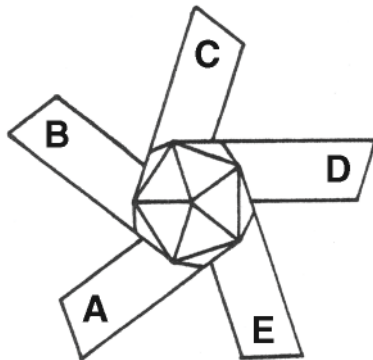

Jupiter (#7) by Stewart Coffin



Jupiter (#7) in zebrawood, Osage orange, tarara, blue mahoe, breadnut & Honduras mahogany by Stewart Coffin



Jupiter (#7) in zebrawood, bloodwood, canarywood, Indonesian rosewood, satinwood & bubinga by Bart Buie

8 Nova

Six identical symmetrical pieces easily assemble to form the second stellation of the rhombic dodecahedron. More of a sculpture than a puzzle. The end blocks in this early version were made by sawing notches into six-sided center blocks. Appeared on 1972 brochure. About 100 made of one-inch zebra wood.

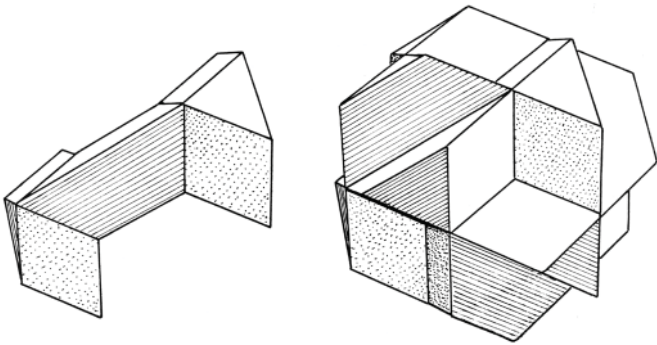

Nova (#8) in rosewood by Stewart Coffin

8-A Nova

A plastic version based on **Nova** (#8), also called **Nova**, was made by Skor-Mor for their Geo-Logic series.

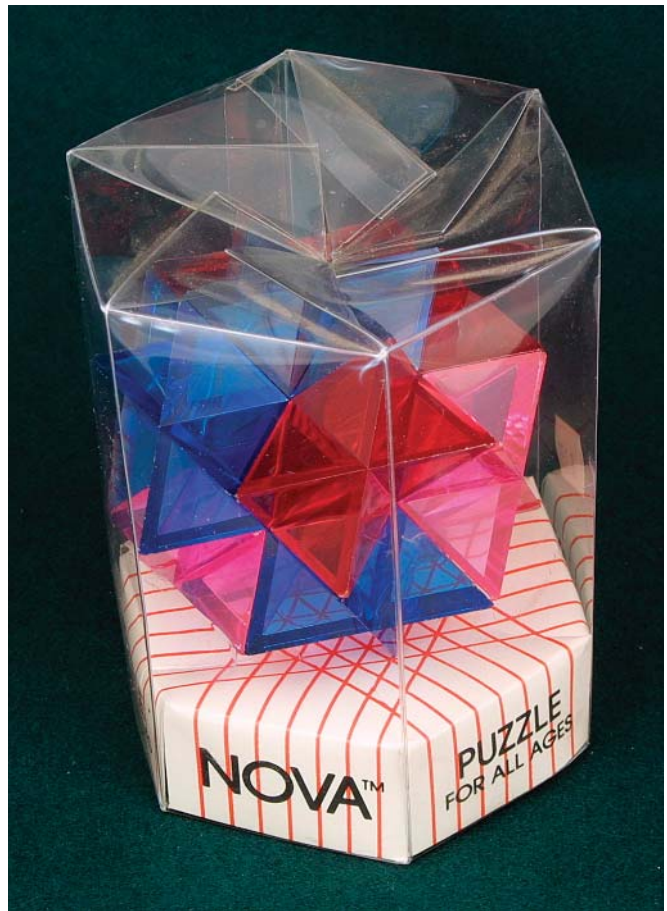
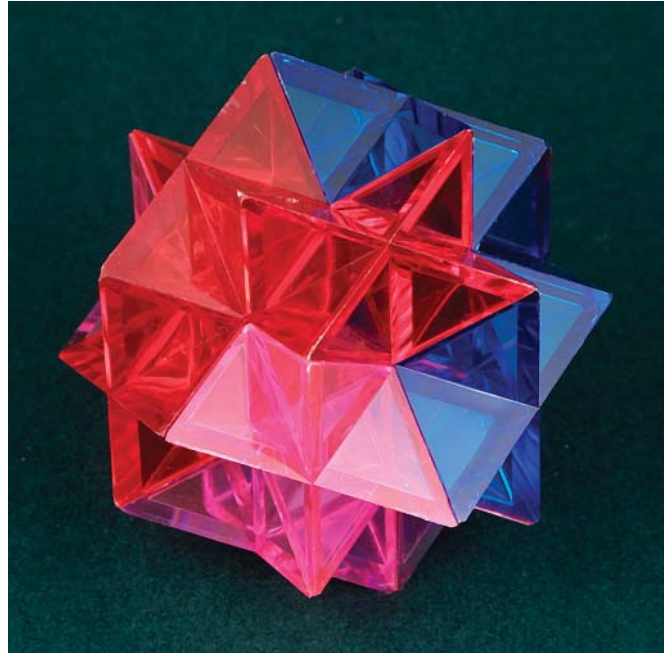

Nova (#8-A) in styrene by Skor-Mor

8-B Nova

There was also a special fancy version, with the end blocks in four contrasting woods. The color scheme is shown, together with a representation of three different forms of color symmetry possible. See *The Puzzling World of Polyhedral Dissections*, page 87. Three made in 1987.

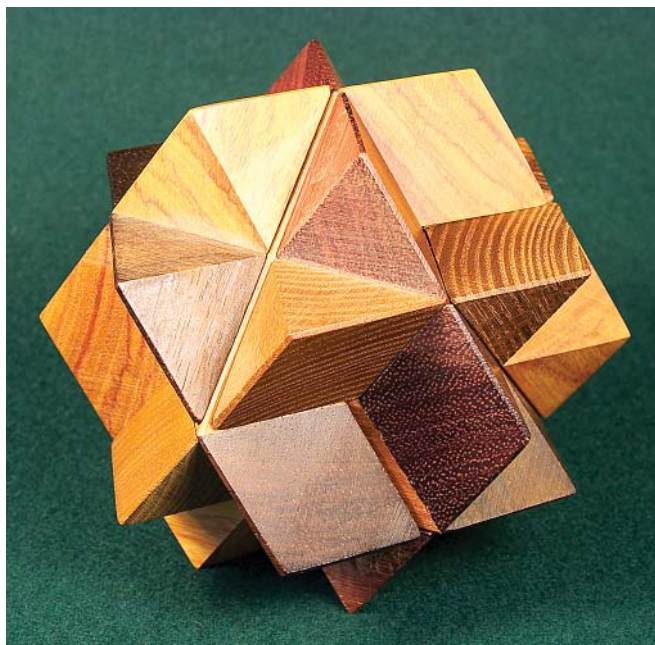
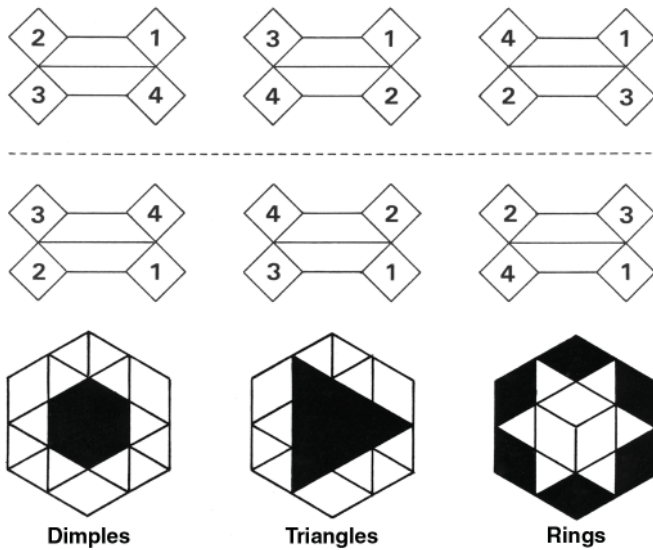

Nova (#8-B) in tulipwood, purpleheart, Osage orange & mahogany by Stewart Coffin

9 Square Knot

This is my name for a popular 19th century design patented in 1890 by William Altekruze. Twelve identical notched square sticks form an interlocking assembly. The assembly procedure has several variations. Mine were made of 7/8-inch stock in three contrasting fancy woods. Some sets included two extra pieces, later listed as **Plus 2** (#57). Appeared on 1974 and 1975 brochures. About 40 made.

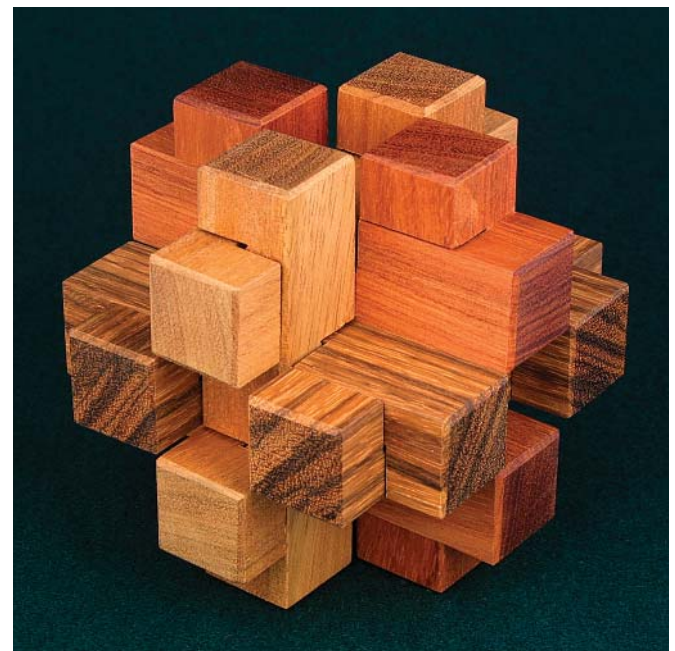
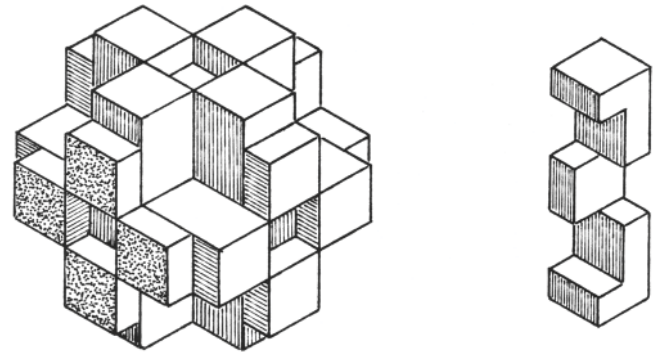

Square Knot (#9) in zebrawood, padauk & satinwood by Stewart Coffin

9-A Frantix

A variation on **Square Knot (#9)** with pins and holes in place of notches. Two kinds of pieces, six of each. Four made in 1973 as a prototype for the plastic version.

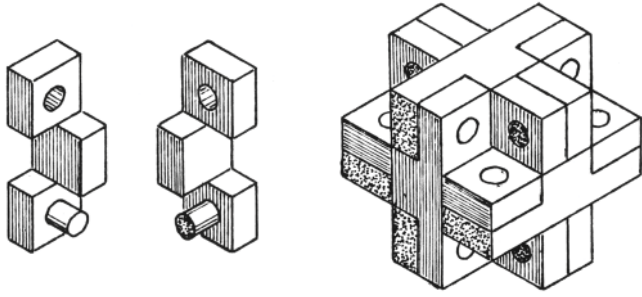

Frantix (#9-A) in Honduras mahogany with birch dowels by Stewart Coffin

9-B Frantix

Licensed to 3M Company in 1974 for manufacture in injection-molded styrene. It was poorly made with tapered holes and not a commercial success.

9-C Frantix

This version has extra pins and holes in the centers, so four kinds of pieces, three of each. About four made around 1973.

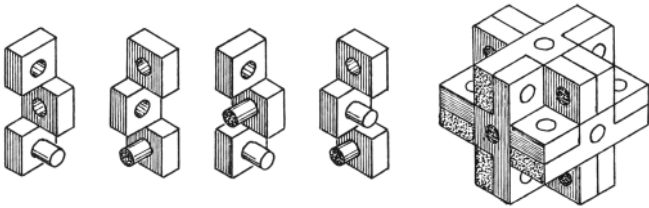

10 Giant Steps

A variation on **Square Knot (#9)**, but hardly an improvement, made by adding extra $1 \times 1 \times 2$ blocks to six of the standard **Square Knot** pieces to make T-shaped pieces. Appeared on 1974 and 1975 brochures. About 20 made, mostly in $\frac{7}{8}$ -inch butternut.

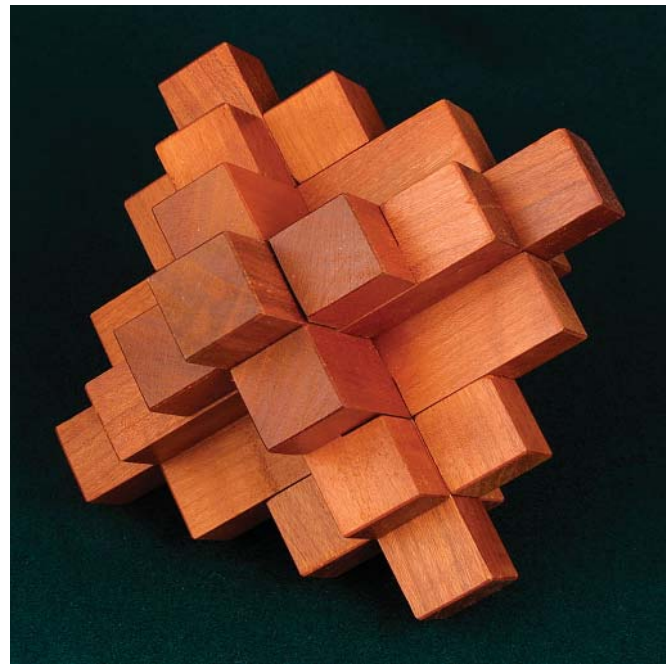
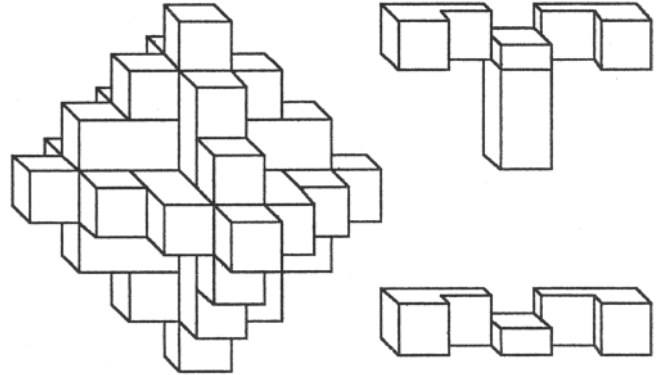

Giant Steps (#10) in butternut by Stewart Coffin

11 Hexagonal Prism

Six dissimilar pieces assemble one way only, with only one sliding axis, a significant departure from all previous AP-ART designs. Appeared on 1974 and 1974 brochures. About 60 made. Many used two dissimilar woods, as indicated in the drawings.

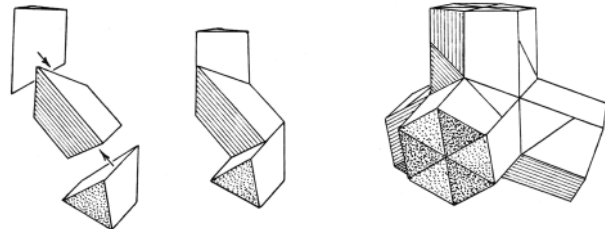

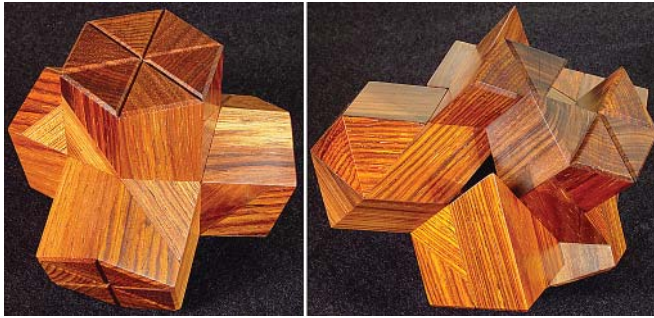
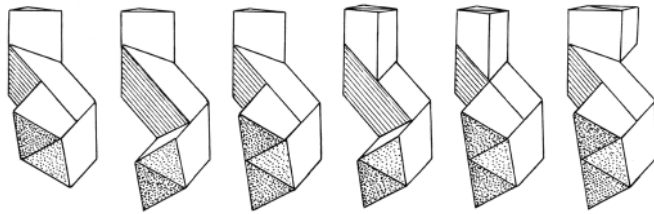

Hexagonal Prism (#11) in Honduras rosewood & cocobolo by Lee Krasnow



Hexagonal Prism (#11) in Honduras mahogany & Brazilian rosewood by Stewart Coffin

12 Triangular Prism

This is a variation of the **Hexagonal Prism** (#11) by adding 12 more blocks, transforming it into a most intriguing solid that reappears in **Burr Muda** (#112). Appeared on 1975, 1975, 1980, and 1981 brochures. About 100 made, mostly in mahogany but a few in rosewood. Used in the IPP-18 puzzle exchange.

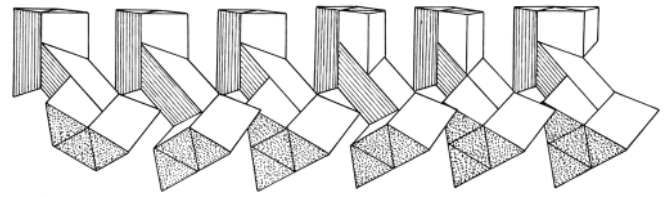
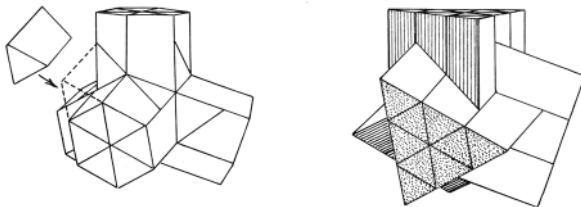

Triangular Prism (#12) in Bolivian rosewood by Lee Krasnow



Triangular Prism (#12) In Brazilian rosewood by Stewart Coffin

12-A Triangular Prism, Elongate Version

This is a slightly different version of **Triangular Prism** (#12), in which the added blocks are attached by their end faces rather than sides. Many other minor variations are possible. Two made around 1974.

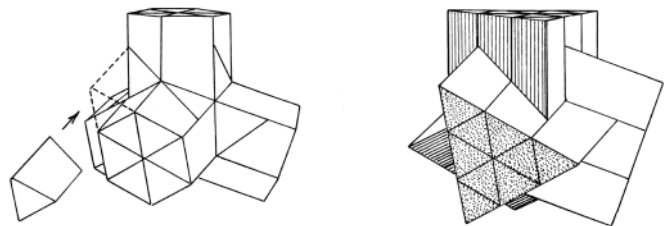

13 The General a.k.a Four Star

This is a variation of the **Triangular Prism** (#12) made by adding yet 12 more blocks. Appeared on 1974 and 1975 brochures. About 20 made, mostly in mahogany, but a couple in rosewood.

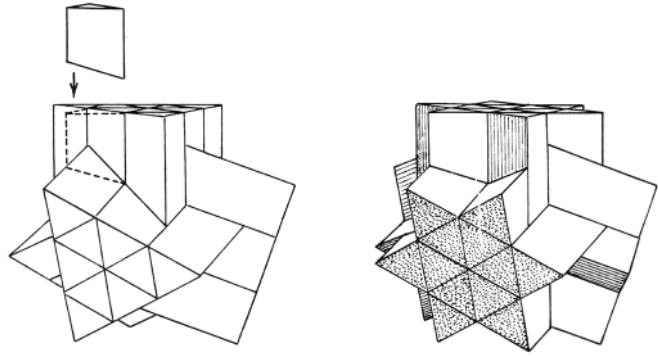
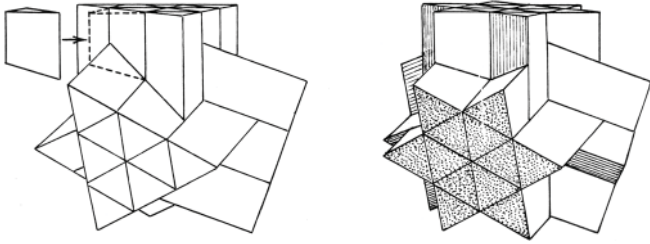

The General (#13) in almond by Stewart Coffin

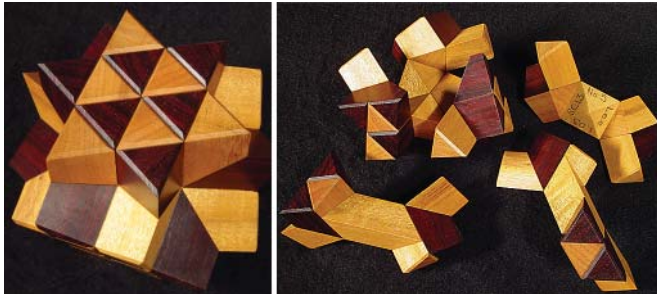

The General (#13) in gonalco alves & bois de rose by Lee Krasnow

13-A. The General, Elongate Version

Same idea as **Triangular Prism, Elongate Version** (#12-A). Added blocks attach by end faces. One made, around 1974.

13-B Ring of Diamonds

An improved variation of **The General** (#13) using rhombic rather than triangular stick segments. Neater and easier to make. Evidently designed in 1973 and forgotten, then rediscovered in 1995. A few made in 1995.

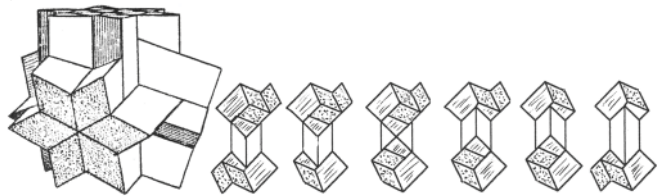

Ring of Diamonds (#13-B) in walnut by Stewart Coffin

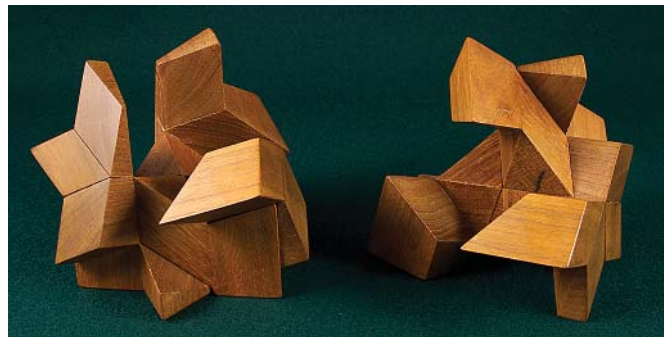

Ring of Diamonds (#13-B) halves separated

14 Super Nova

Same shape as **Nova** (#8) when assembled (second stellation of the rhombic dodecahedron) but with six dissimilar non-symmetrical pieces, making it a genuine puzzle. Has two solutions. Appeared on 1974 and 1975 brochures. About 20 made.

14-A Second Stellation

A reissue of the **Super Nova** (#14), more accurately made in mahogany. Appeared on 1981 brochure. About 50 made.

A further improved version of the **Second Stellation** was made starting in 1983, using triangular rather than square stock. About 50 made in mahogany.

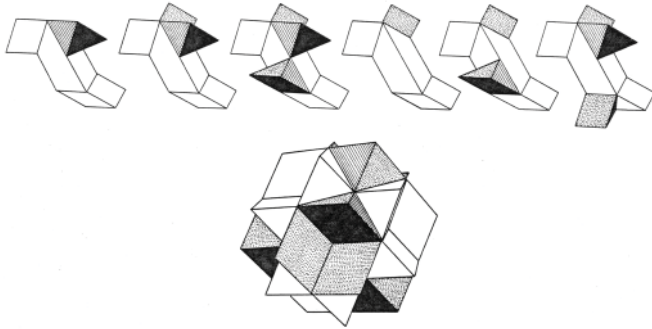

Second Stellation (#14-A) in bocote by Bart Buie



Second Stellation (#14-A) in Bolivian rosewood, Mexican kingwood, oily bocote & Macassar ebony by Lee Krasnow

14-B Augmented Second Stellation

A variation of the **Second Stellation** (#14-A) in which the arms are lengthened to make a different shape. Only two made in 1990. It was reissued in 1996 using 0.800-inch stock (20% smaller) in four contrasting fancy woods and a few more made.

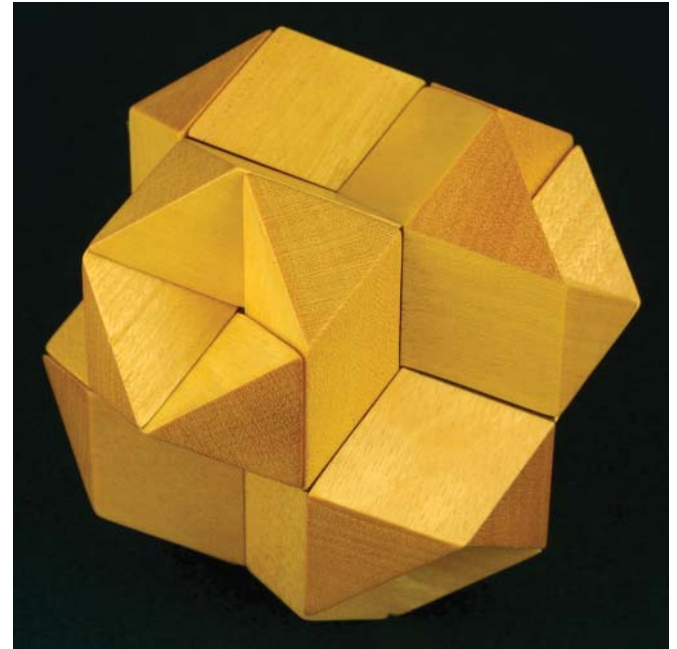

Augmented Second Stellation (#14-B) in yellowheart & Bolivian rosewood by Lee Krasnow



Augmented Second Stellation (#14-B) partially disassembled

15 Triumph

The six identically shaped pieces somewhat resemble those of the **Four Corners** (#6), but have bilateral rather than axial symmetry. They assemble into three different symmetrical polyhedral shapes, the first AP-ART design with this feature (with many more to follow). Each piece is made up of two dissimilar contrasting woods, which introduces color symmetry considerations in the solutions. For more information, see the instruction sheet. Appeared on 1974 and 1975 brochures. About 50 made until superseded by **Fusion-Confusion** (#15-A).

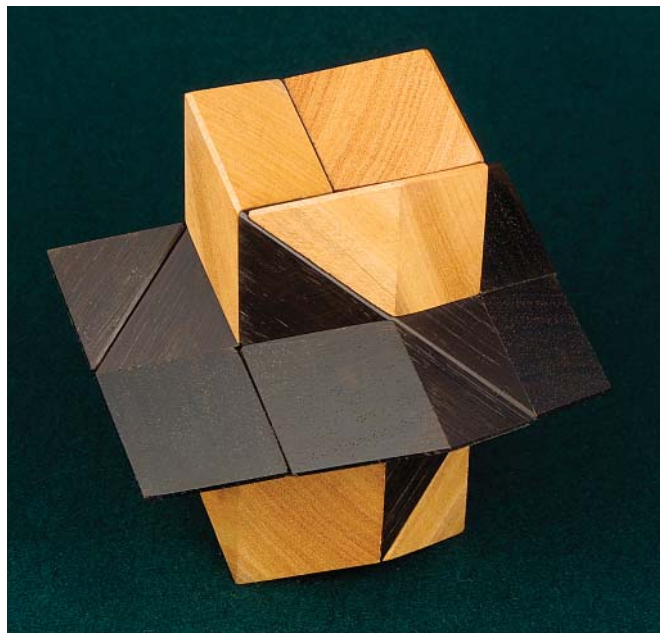
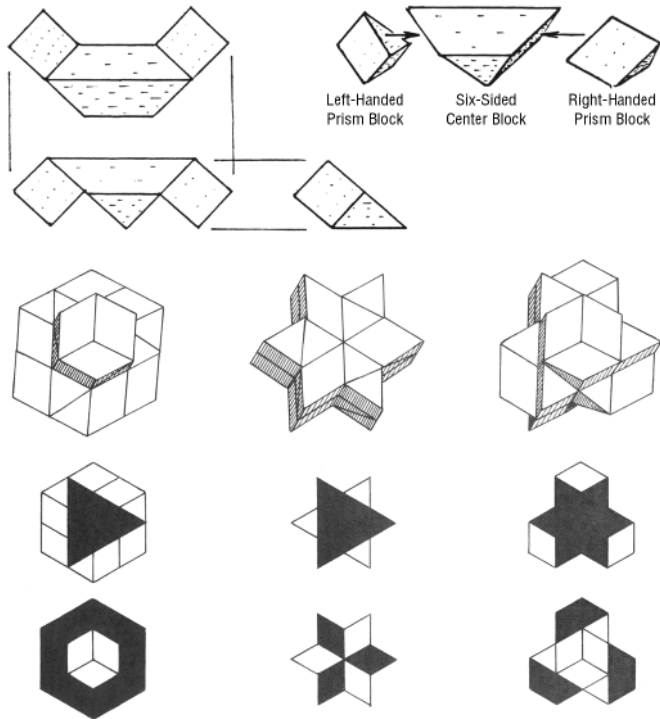

Triumph (#15) in Brazilian rosewood & peroba rosa by Stewart Coffin

15-A Fusion-Confusion

Think of this as a **Triumph** (#15) puzzle in which two pairs of pieces have been joined together, resulting in four utterly confusing puzzle pieces. They assemble to form four different symmetrical shapes, as shown, the *strange* shape being a mirror-image pair. More information on instruction sheet. First made in 1990. About 40 made in multicolored fancy woods.

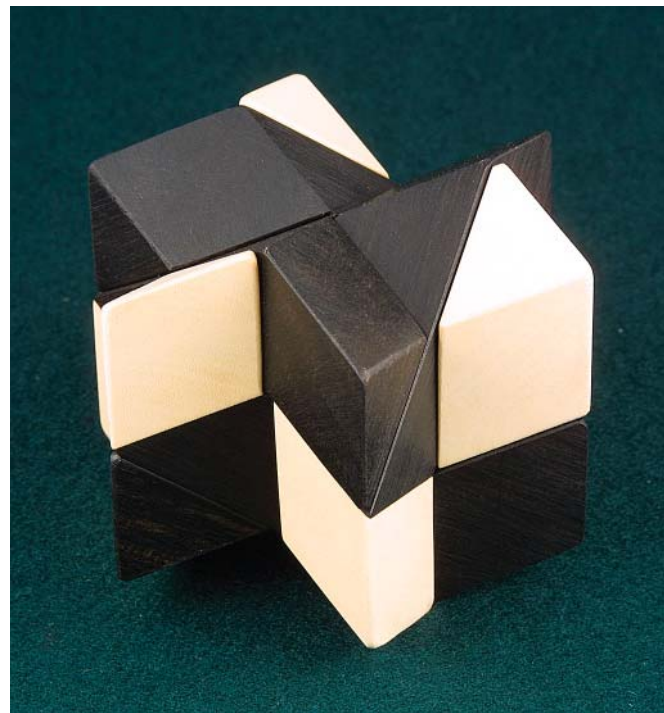
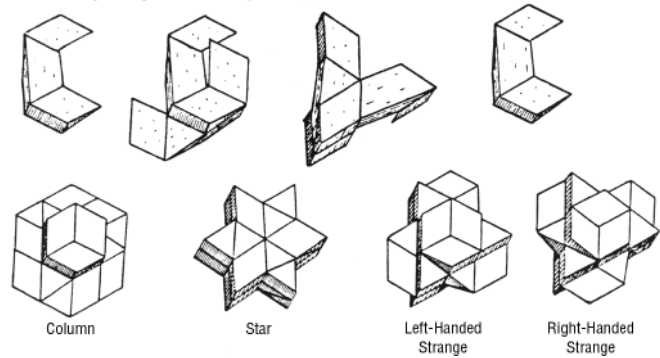

Fusion Confusion (#15-A) in Gaboon ebony & holly by Tom Lensch

15-B Triumph Companion

A couple of these puzzles were made as companions for the **Triumph** (#15) puzzle. The two photographs show the **Triumph** and its pieces on the left with the **Triumph Companion** and its pieces on the right. There are three of each piece in both puzzles. The top **Triumph Companion** piece has a six-sided center block on one end and a left-handed prism block on the other. The bottom piece has right-handed prism blocks on both ends. The **Triumph Companion** puzzle has eight symmetrical solutions. By interchanging sets of the three pieces between the two puzzles, a great many new and interesting shapes are possible. I haven't bothered to figure out how many. I'll leave that up to you.

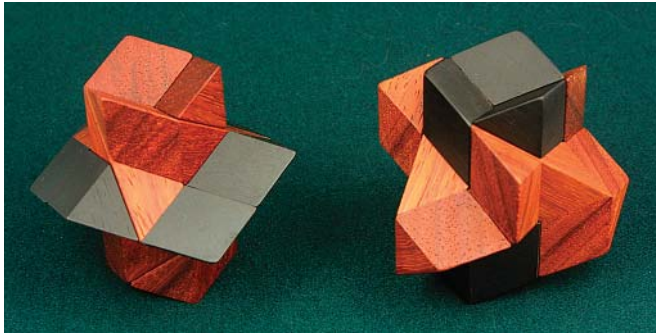

Triumph and Companion (#15 & #15-B) in *padauk & Gaboon ebony* by Tom Lensch

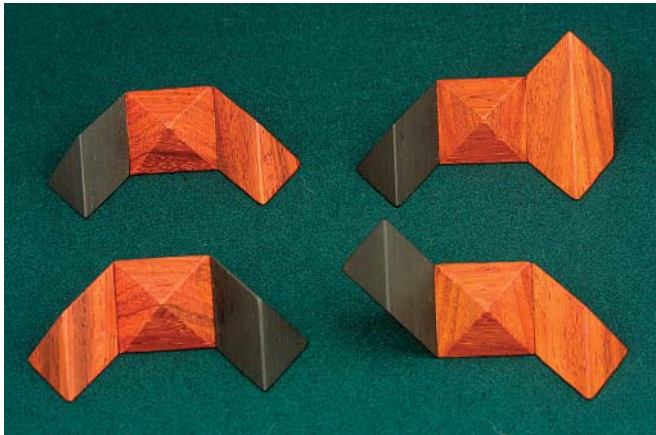

Triumph and Companion (#15 & #15-B) pieces

16 Dislocated Scorpis

This design closely resembles the **Scorpis** (#5), but one arm in each piece has been displaced, making the six identical pieces non-symmetrical. This also makes the assembled puzzle more interlocking and somewhat more confusing to assemble and disassemble. Appeared on 1974 and 1975 brochures. About 20 made. Then superseded by the **Scrambled Scorpis** (#23).

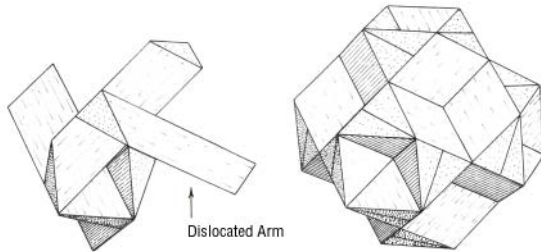

17 Dislocated Jupiter

This is a variation of the **Jupiter** (#7), analogous to the **Dislocated Scorpis** (#16). There are at least two different solutions. A complete analysis was never made. Appeared on 1974 and 1975 brochures. About 10 made in one wood. Then superseded by the **Saturn** (#24).

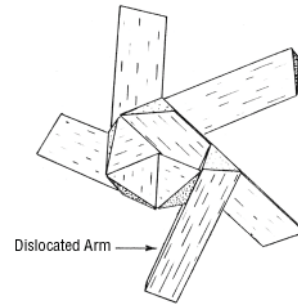

18 Abbie's Waffle

Six pieces, each made of four cubic blocks, assemble various ways onto a square tray or into a $2 \times 3 \times 4$ box. Created by my daughter and demonstrated by her on the PBS children's program ZOOM, Dec. 9, 1973. The instruction sheet shows various problems. Appeared on 1975 brochure. About 10 made.

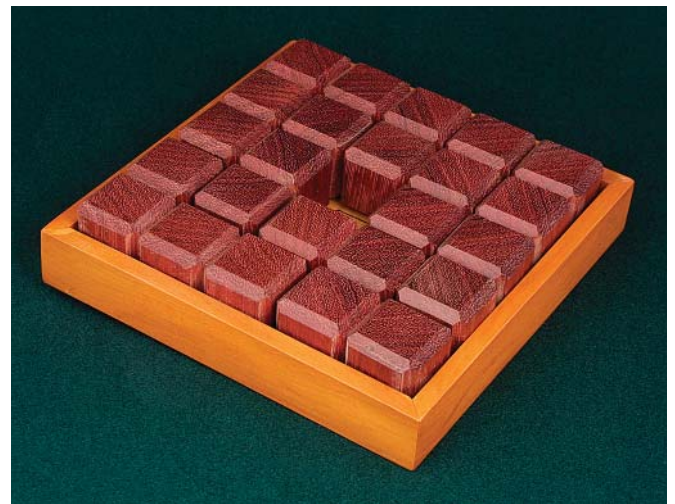
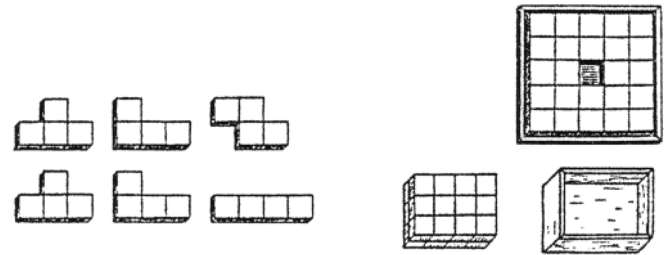

Abbie's Waffle (#18) in *purpleheart* with *peroba rosa & mahogany* tray by Stewart Coffin

18-A Joined Pairs

The six pieces are made of two $1 \times 1 \times 2$ blocks joined together all possible ways. They pack into a $2 \times 3 \times 4$ box various ways. One solution has a sort of symmetry. An obvious idea, probably discovered independently by others. One made in 1990.

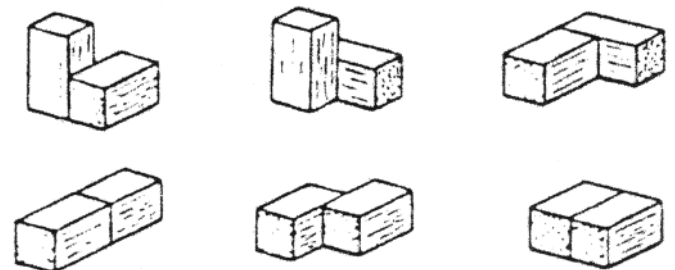

19 Pyracube

Four of the pieces are made of truncated rhombic dodecahedra (or edge-beveled cubes) joined different ways and the fifth piece is a single block, for a total of 19 blocks. They pack snugly into the cubic box with or without the single block. The instruction sheet shows other problems. Appeared on 1975 brochure. About 20 made. A variation of this design using spheres appears in *Creative Puzzles of the World* by van Delft & Botermans, page 85.

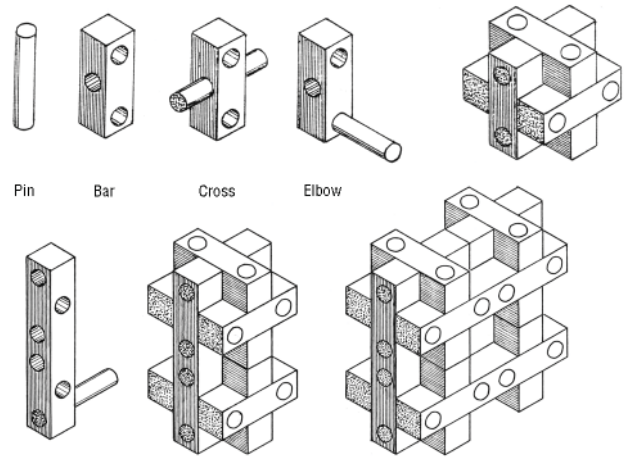
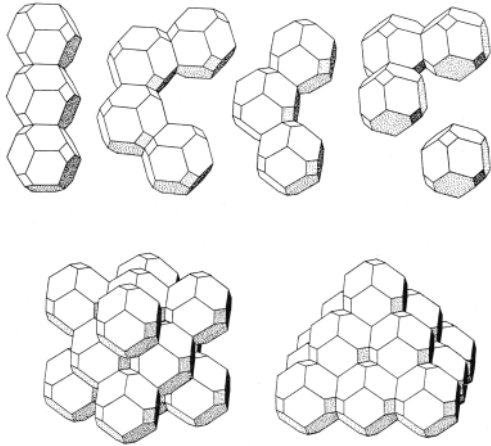

Pyracube (#19) in Honduras rosewood with blue mahoe box by Stewart Coffin

20 Pin-Hole

Six $1 \times 1 \times 3$ bars with pins and holes assemble easily into a burr. By adding one or more pieces twice as long, more complicated assemblies are possible, as explained in the instruction booklet. Appeared on 1977 and 1978 brochures. About 50 sets made in cherry and birch.

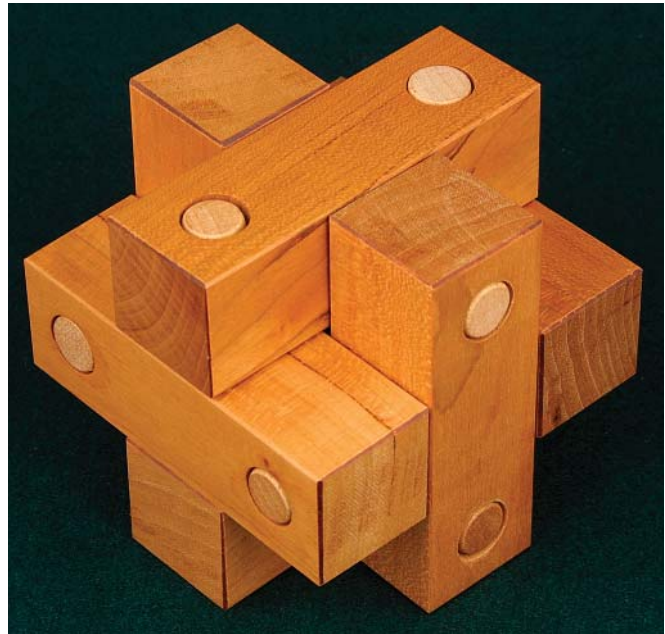

Pin-Hole (#20) in cherry & birch by Stewart Coffin



Pin-Hole (#20) Grand Cross variation in cherry & birch by Stewart Coffin

20-A King Pin

This was a variation of **Pin-Hole** (#20) with blind holes and free pins as a sort of puzzling large construction set. It never got beyond the development stage in 1975.

20-B Goose

This was to be a variation of **King Pin** (#20-A) with animated figures. It too never got beyond the development stage in 1986.

21 Cuckoo Nest

Six hexagonal bars are pinned together with six dowels. Appeared on 1977, 1978, and 1979 brochures. About 100 made in birch.

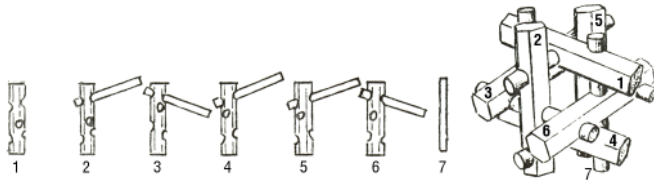

Cuckoo Nest (#21) in birch by Stewart Coffin

22 Locked Nest

Twelve hexagonal bars are pinned together with 12 dowels in a symmetrical assembly. There are two versions. Most of those made have five elbow pieces, but the more interesting version has six. Appeared on 1977, 1978, and 1979 brochures. About 100 made in birch, and a few in fancier woods.

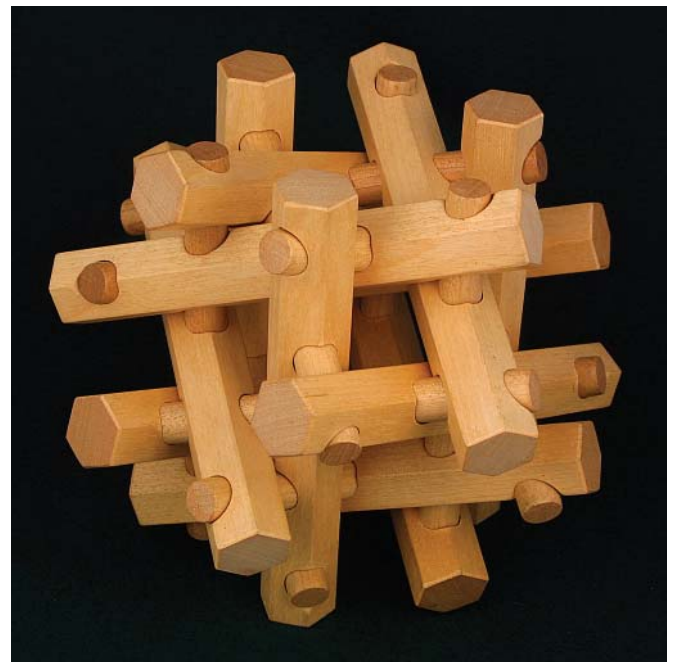
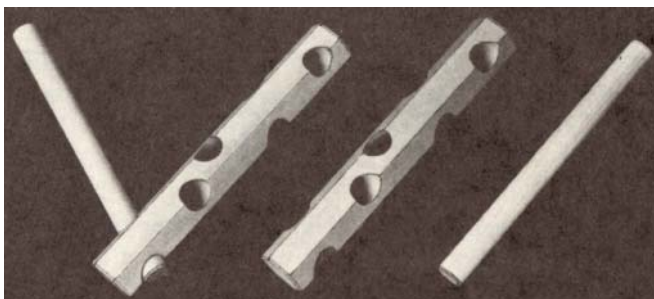

Locked Nest (#22) in birch by Stewart Coffin

22-A Locked Nest, Three-Hole Version

This is simply a variation of **Locked Nest** (#22) in which the bars and dowels are shortened so that the end holes are eliminated. One made in 1990. Never illustrated, so use your imagination.

22-B Siamese Locked Nests

Two **Locked Nests** (#22) joined together using longer bars. Two made in 1989. Many other variation on this theme are possible.

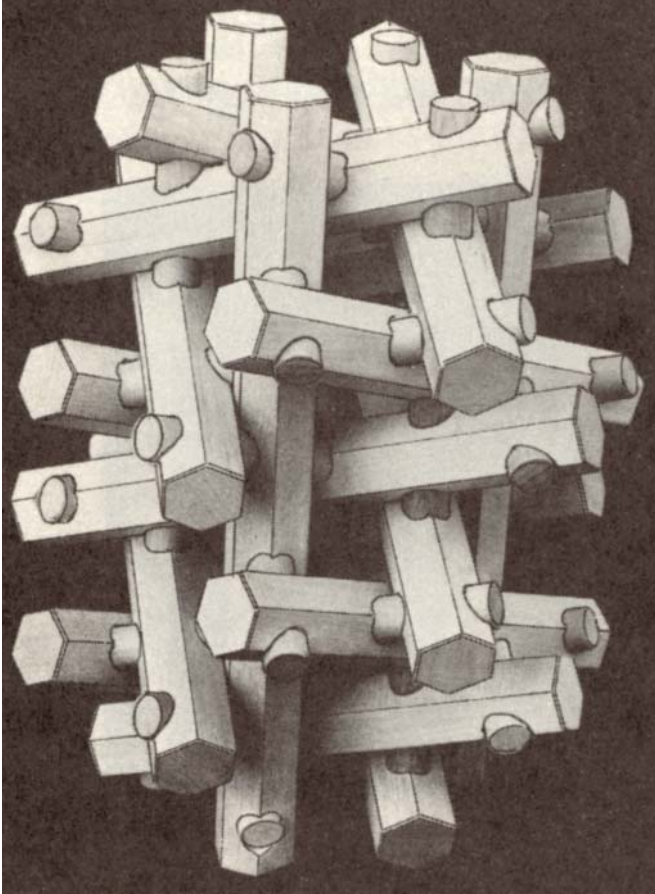

Scrambled Scorpius (#23) in tulipwood by Bart Buie



Scrambled Scorpius (#23) partially disassembled

23 Scrambled Scorpius

A derivative of **Scorpius** (#6) in which all pieces are dissimilar and non-symmetrical. Only one solution, one sliding axis, and one order of assembly. Difficult, and overall one of my most satisfactory AP-ART designs. Appeared on 1978, 1979, 1980, and 1981 brochures. About 200 made, mostly in mahogany but some in exotic woods with doweled joints.

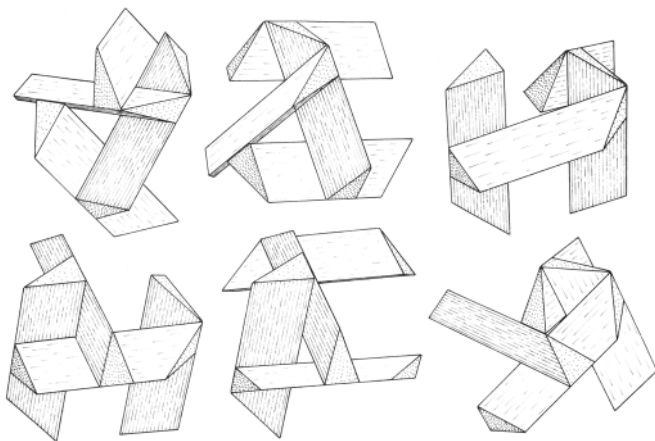

23-A Egyptian

This is an enlarged version of **Scrambled Scorpius** (#23) with the solution marked in code on the inside. A few made in oak, 1993-1995.



Egyptian (#23-A) in oak by Stewart Coffin

24 Saturn

A derivative of **Jupiter** (#7), but with six kinds of pieces, two of each, all non-symmetrical and same size. Intended to have only one solution, but other solutions discovered by Stan Isaacs. Appeared on 1978, 1979, 1980, and 1981 brochures. About 65 made, mostly in one kind of fancy wood. The deluxe version has six kinds of wood and doweled joints. Superseded by **Sphinx** (#156).

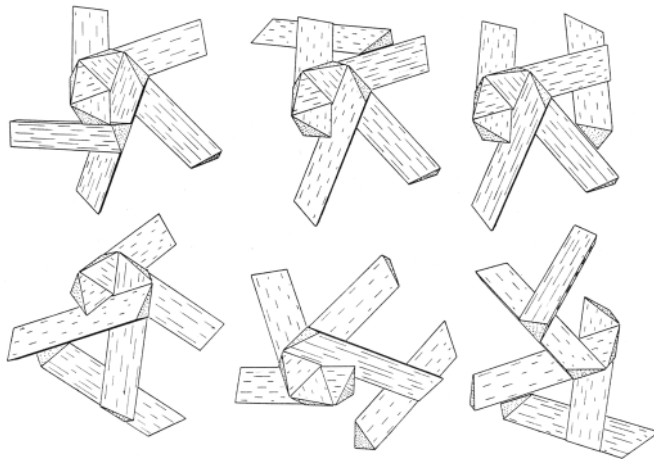

Saturn (#24) in tarara, tulipwood, rosewood, breadnut, satinwood & purnambuco by Stewart Coffin

25 Hectix

Twelve notched hexagonal bars interlock to form a symmetrical burr. Nine bars have two notches and three bars have three notches. There are three distinctly different solutions. US Patent 3721448. (Discovered independently by Bill Cutler around 1965.) Licensed to 3M Company. About 100,000 made, in white injection molded styrene and a few Executive Models in clear styrene with air bubbles.

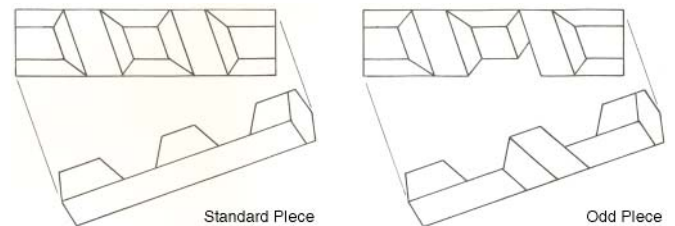

Hectix, Executive Model (#25) in styrene by 3M

25-A Hexsticks

This is my wooden version of **Hectix** (#25) in which seven bars have two notches, three bars have three notches, and two bars have one notch. Same three solutions possible. Appeared on 1979 and 1981 brochures. About 150 made, mostly birch. Unlicensed reproductions have been made in Japan, Australia, and probably many other places.



Hexsticks (#25-A) in birch by Stewart Coffin

25-B Giant Hexsticks

Wooden version of **Hectix** (#25) but twice the size, 1.5-inch hexagonal stock. A few made in 1993.



Giant Hexsticks (#25-B) in cherry by Stewart Coffin

25-C Four-Color Hexsticks

A wooden version of the original **Hectix** (#25), but in four contrasting colors as it was supposed to have been manufactured but never was. Also in one-inch rather than $\frac{3}{4}$ -inch hex size. A few made in 1995.



Four-Color Hexsticks (#25-C) in padauk, purpleheart, pine & cherry by Stewart Coffin

25-D Hectix

A wooden version licensed to Bits & Pieces, listed in their 1996 catalog and evidently made by them, although I have never seen one.

26 Four-Piece Pyramid

Four pieces, each made up of five rhombic dodecahedral blocks joined different ways, assemble with remarkable confusion one way and in one order only to form a triangular pyramid. Appeared on 1979 and 1981 brochures. The first twelve, made in 1976, used edge-beveled rosewood cubes and doweled joints. The next 30, made around 1979, used one-inch cherry rhombic dodecahedron blocks. About 25 were made starting in 1981 with larger edge-beveled cubes. In 1997 a few were made in contrasting fancy woods.

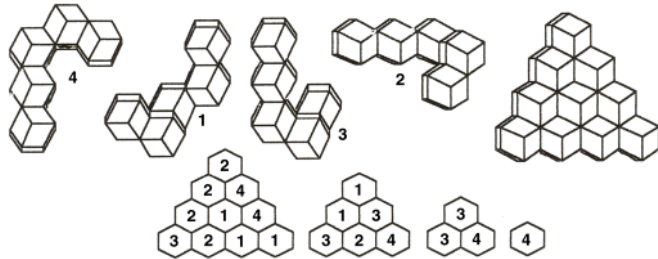

Four-Piece Pyramid (#26) made from edge-beveled cubes in locust, walnut, cherry & purpleheart by Stewart Coffin

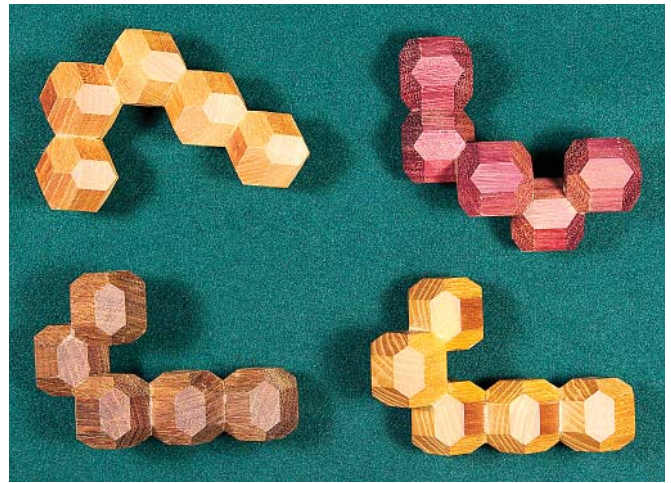

Four-Piece Pyramid (#26) pieces

27 Three Pairs

Two kinds of pieces, three of each, assemble with surprising difficulty. My first truly coordinate motion puzzle, and still one of the best. Appeared on 1979 and 1981 brochures. About 150 made in mahogany. In 1986 a deluxe edition of 10 was made of rosewood with doweled joints.

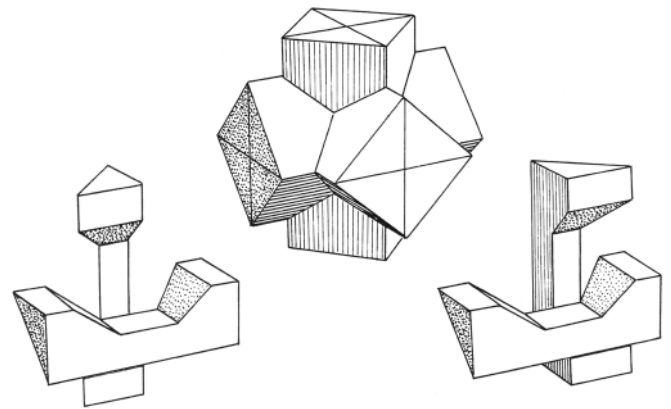

Three Pairs (#27) in Brazilian rosewood by Stewart Coffin

27-A Three Pairs Variations

Several variations are possible, all with the same internal function but with different external shape. I have made rough working models having the shape of the **Star** (#4-A) and **Four Corners** (#6). A version made by Interlocking Puzzles (shown in the photograph) having the shape of **Nova** (#8) and called **Split Second** was used in the IPP-19 puzzle exchange.



Split Second (#27-A) in peroba rosa by Interlocking Puzzles

28 Truncated Octahedra

Five pieces made of 14 truncated octahedral blocks pack neatly into a square box. The 12-page booklet shows 18 other problems. Appeared on 1979 and 1981 brochures. About 50 made by starting with 1.5-inch mahogany cubes and removing corners. The novel box of Baltic birch could be inverted to hold the square pyramid.

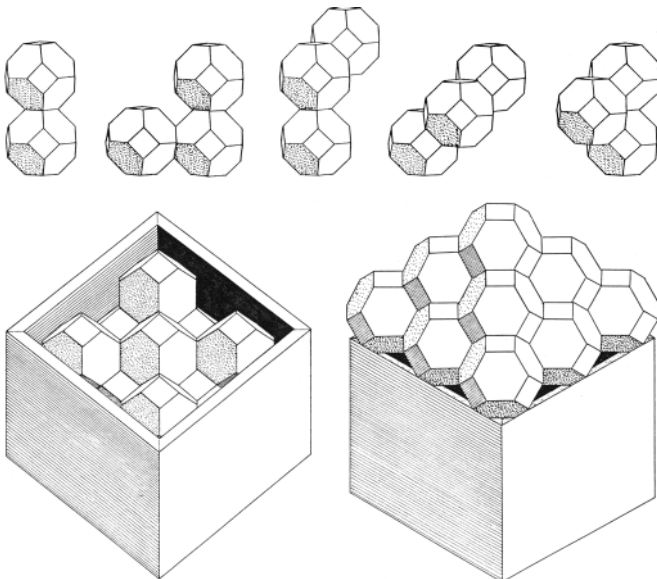

Truncated Octahedra (#28) in mahogany with birch box by Stewart Coffin

29 Half-Hour

An ordinary six-piece $3 \times 3 \times 3$ cubic dissection. The object was to discover the most difficult possible design in this class. Consequently all pieces are dissimilar and as non-symmetrical as practical, with unique solution. Dozens of other problem shapes were later submitted by H. Havermann and D. Barge. Appeared on 1980 and 1981 brochures. About 50 made of one-inch stock. Reissued in 1984 using six fancy woods and a box of blue mahoe.

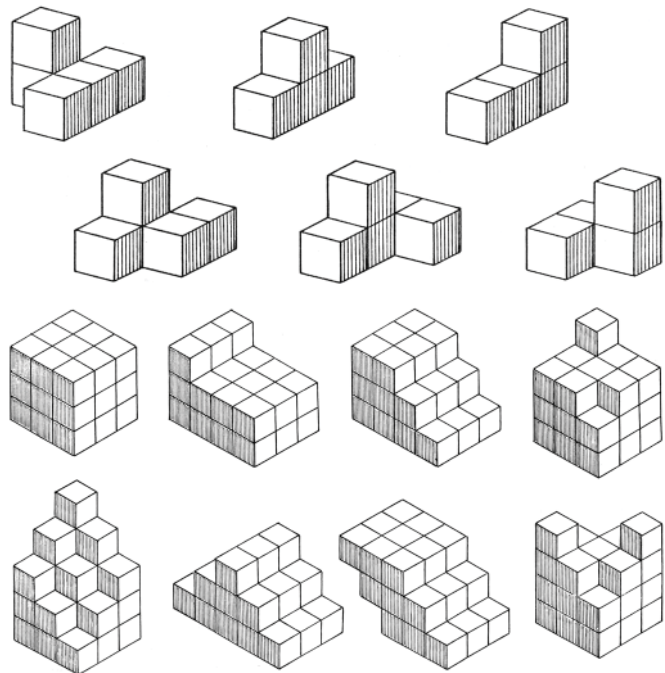

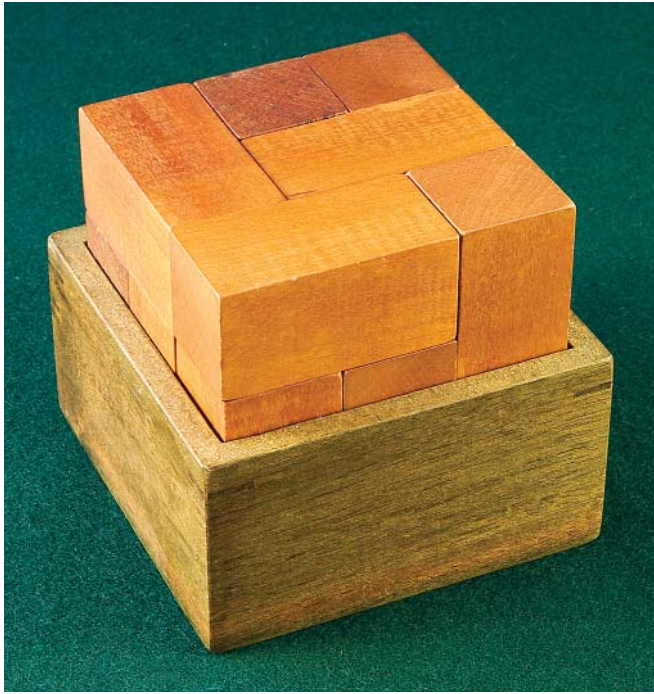

Half Hour (#29) in cherry with blue mahoe box

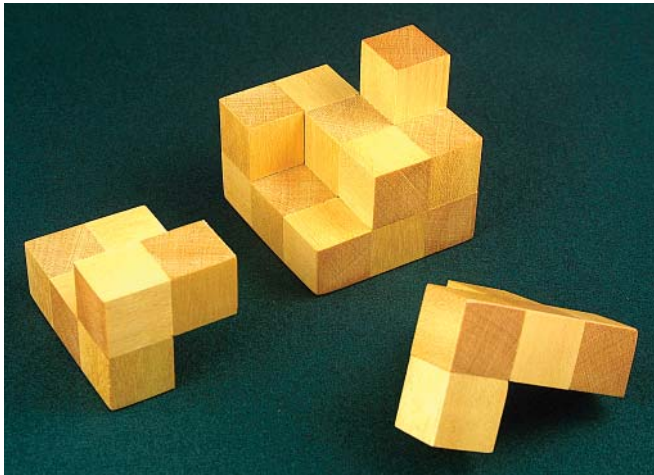

Half Hour (#29) in yellowheart by Tom Lensch

30 Convolution

Seven pieces assemble one way only and in only one order to form an interlocking 4x4x4 cube with symmetrical pattern on all six faces. Appeared on 1980 and 1981 brochures. About 50 made of 3/4-inch stock.

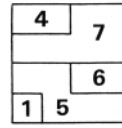

Top Layer

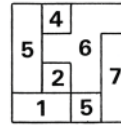

Second Layer

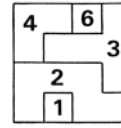

Third Layer

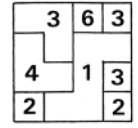

Bottom Layer



Convolution (#30) in zebrawood & Indian rosewood by Bart Buie



Convolution (#30) partially disassembled

31 Octahedral Cluster

Four pieces made up of 19 rhombic dodecahedron blocks assemble one way only and in only one order to form an interlocking octahedral cluster. If you think the **Four-Piece Pyramid** (#26) is confusing, this one is even more so. Appeared on 1980 and 1981 brochures. About 40 made of limba.

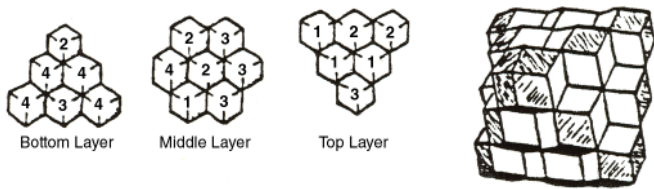

Octahedral Cluster (#31) made from rhombic dodecahedron blocks, in Spanish cedar by Stewart Coffin



Octahedral Cluster (#31) made from edge-beveled cubes, in Philippine mahogany by Stewart Coffin

31-A Five-Piece Octahedral Cluster

Like **Octahedral Cluster** (#31) except one more piece and even more confusing. A few were made recently of edge-beveled cubes. One drawback—the lone block, which goes in last as the key piece, tends to fall out easily unless very accurately made.

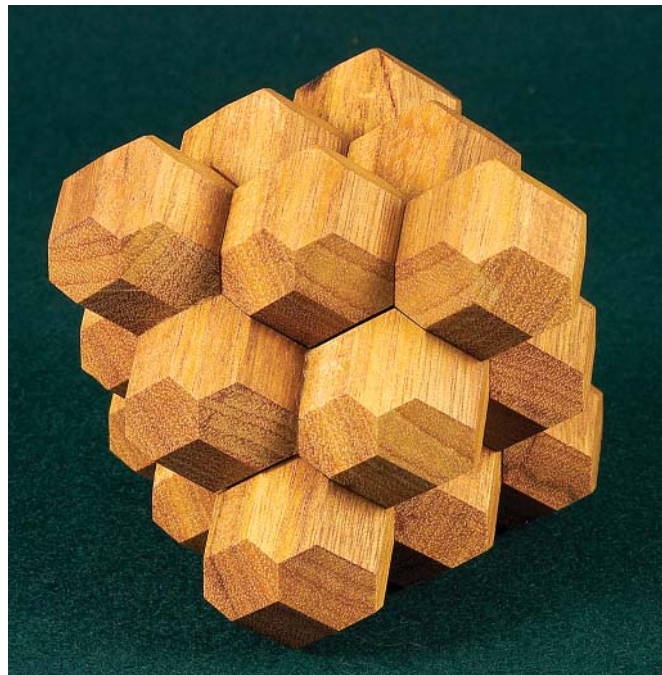
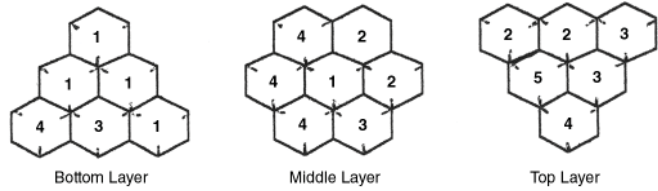

Five-Piece Octahedral Cluster (#31-A) in camphorwood by Stewart Coffin

32 Broken Sticks

Six dissimilar pieces made of triangular stick segments joined together various ways assemble one way only with one sliding axis. Difficult. Appeared on 1980 and 1981 brochures. About 50 made until superseded by **Twelve Point** (#33).

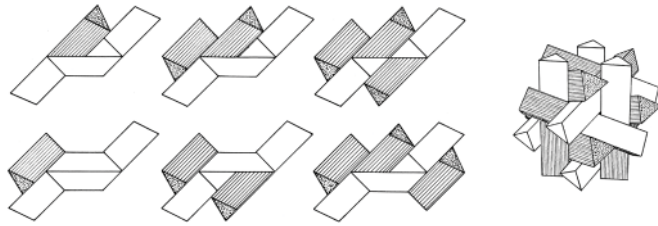

Broken Sticks (#32) in mahogany by Stewart Coffin



Broken Sticks (#32) partially disassembled, in Macassar ebony, Gaboon ebony, airy Cambodian rosewood, Bolivian rosewood & bloodwood Lee Krasnow

33 Twelve Point

Six dissimilar pieces assemble one way only with one sliding axis to form an intriguing solid intermediate between the second and third stellations of the rhombic dodecahedron. Appeared on 1981 brochure. About 50 made of one-inch stock in two contrasting fancy woods. This neat puzzle, not too difficult to make and ought to be reissued.

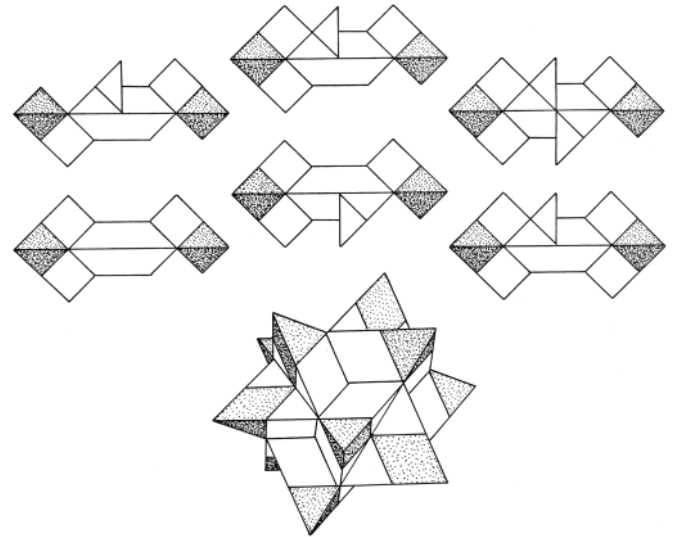

Twelve Point (#33) in bois de rose & jatoba by Lee Krasnow

33-A Twelve Point

This was a remake of the original **Twelve Point** (#33) in 0.800-inch stock. A few made in 1996.

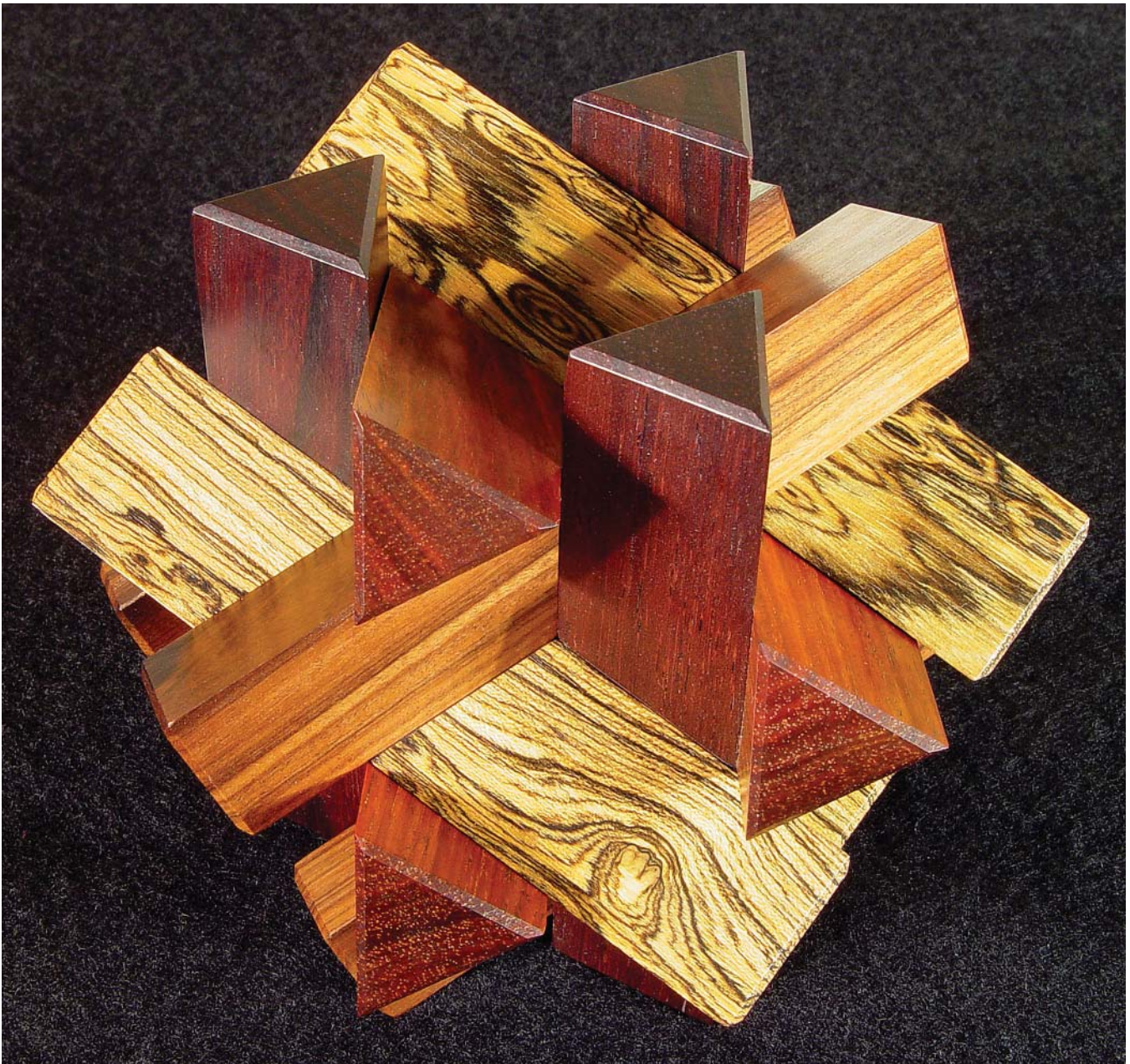

Broken Sticks (#32) in pao ferro, dense Cambodian rosewood, bois de rose & figured bocote by Lee Krasnow

34 Augmented Four Corners

Six pieces assemble one way only and with one sliding axis. Appeared on 1981 brochure. About 60 made of one-inch stock in two contrasting fancy woods.

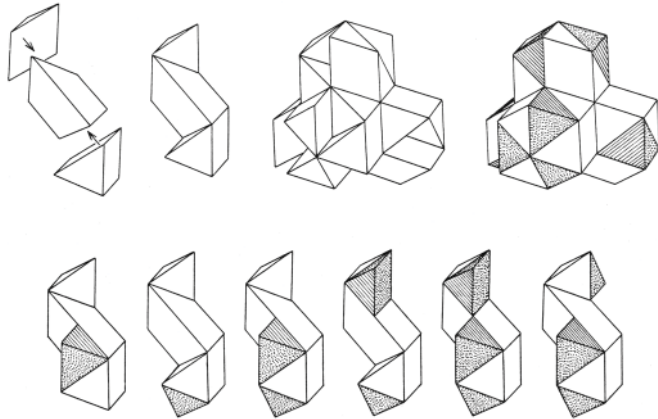

Augmented Four Corners (#34) partially disassembled, in bubinga & Bolivian rosewood by Lee Krasnow

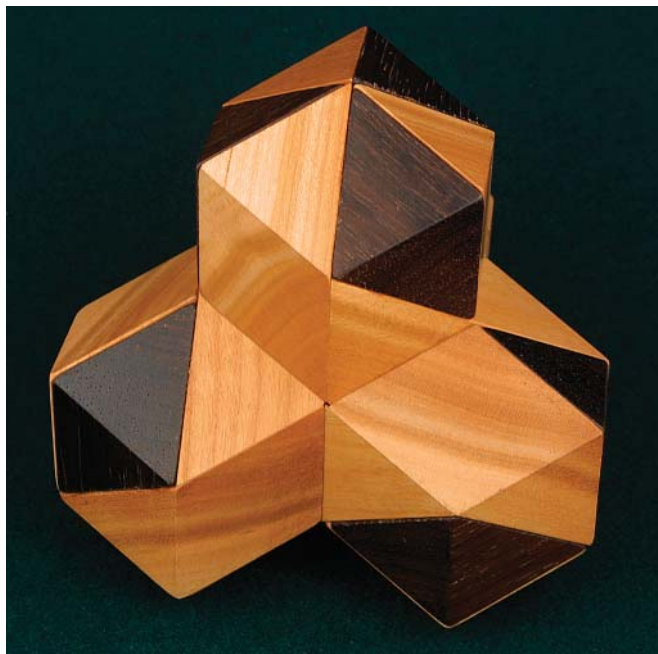

Augmented Four Corners (#34) in cherry & Brazilian rosewood by Stewart Coffin

34-A Augmented Four Corners Variations

These are variations of the **Augmented Four Corners** (#34) made by sawing or sanding down the various faces of the assembled puzzle to achieve interesting sculptural effects, especially when using contrasting woods. Two versions were made, one model of each, probably in early 1970's. Two other versions were made in 2003, again just one model of each. Except for the following photograph, never illustrated, so use your imagination.

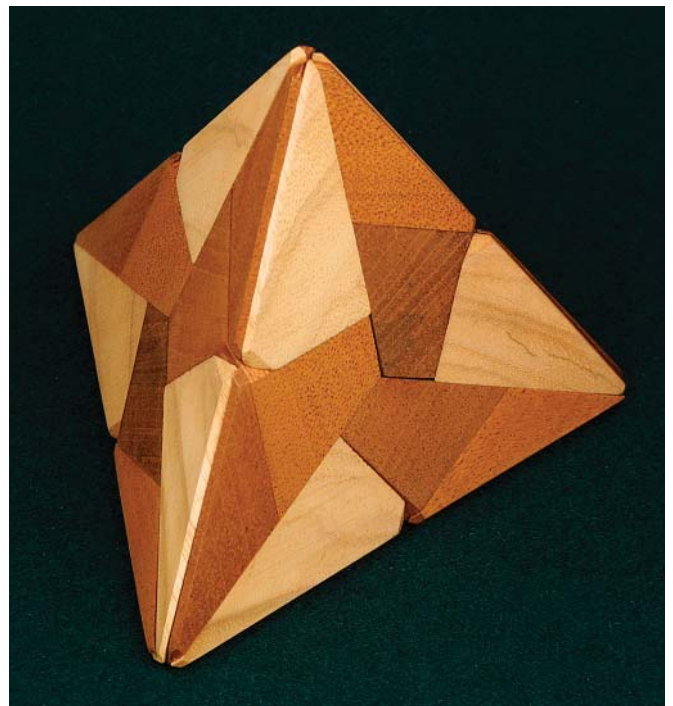

Augmented Four Corners Variation (#34-A) in mahogany & limba by Stewart Coffin

35 Burr#305

Ordinary six-piece notchable burr with unusual 3+3 solution. Appeared on 1981 brochure. About 60 made of one-inch stock.

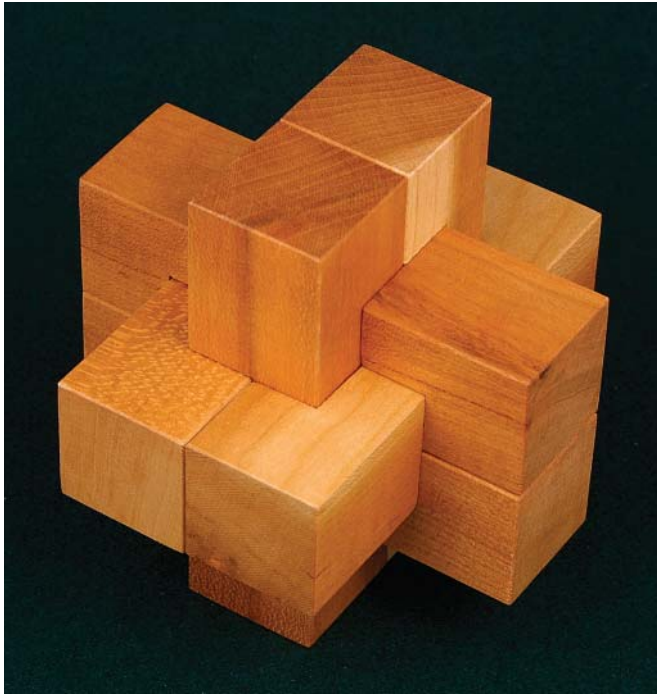
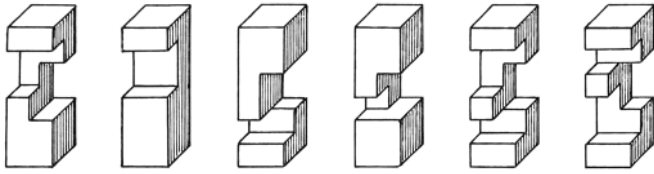

Burr #305 (#35) in cherry by Stewart Coffin

36 Coffin's Improved Burr

More complicated than Burr #305 (#35), with five shifts required to release the first two pieces. Appeared on 1981 brochure. About 50 made.

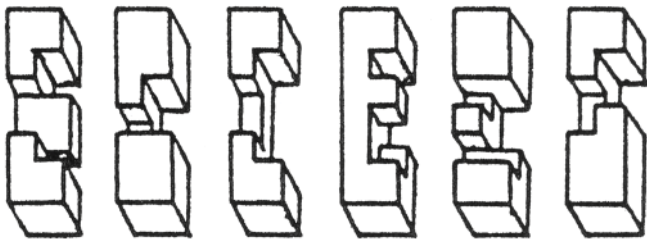

37 Star-of-David

Six dissimilar non-symmetrical pieces assemble to form three different interlocking polyhedral solids with confusing diagonal axis of assembly. Appeared on 1981 brochure. About 50 made of mahogany.

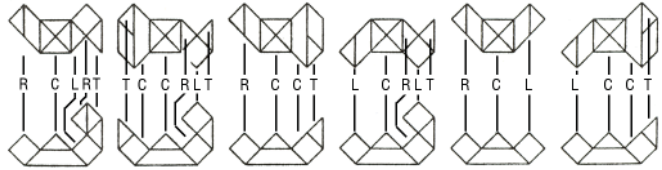

Star-of-David (#37) assembled in "star" configuration, in New Guinea rosewood by Lee Krasnow

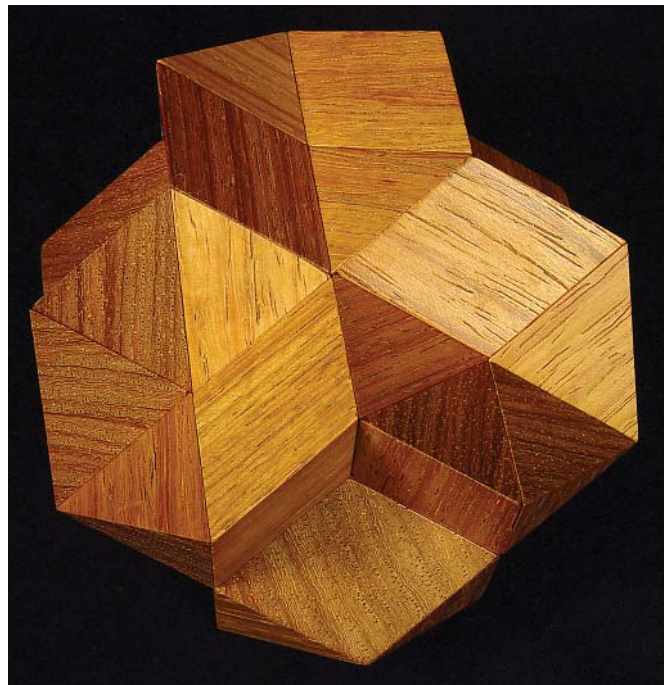

Star-of-David (#37) assembled in "squat" configuration, in New Guinea rosewood by Lee Krasnow

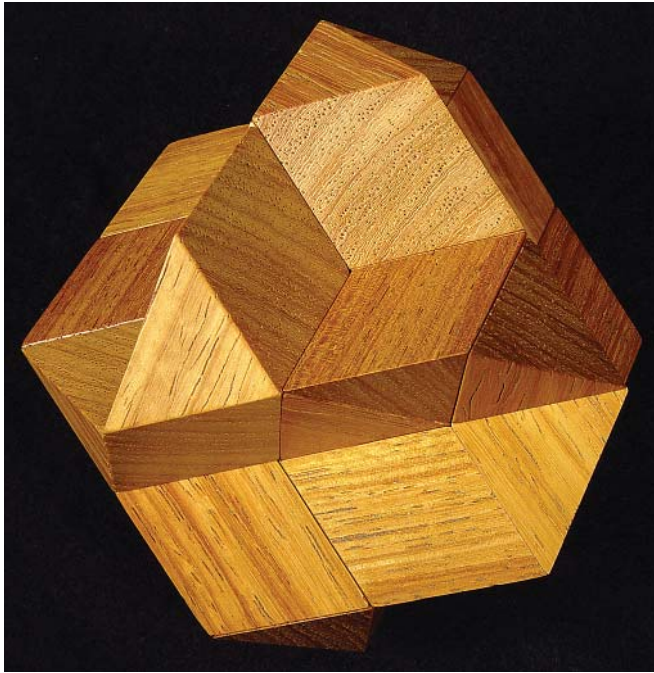

Star-of-David (#37) assembled in "clockwise spiral" configuration, in New Guinea rosewood by Lee Krasnow

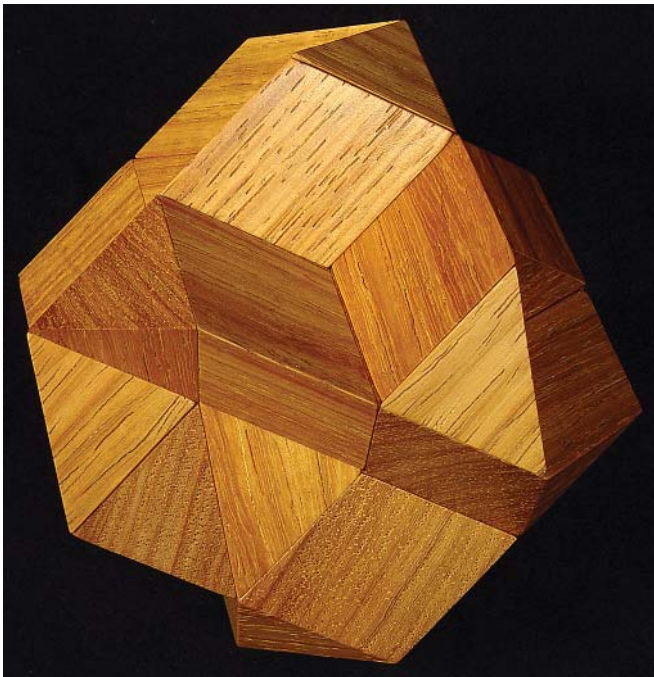

Star-of-David (#37) assembled in "counter-clockwise spiral" configuration, in New Guinea rosewood by Lee Krasnow

37-A Star-of-David, Improved

Same object as **Star-of-David (#37)**, but achieved with simpler pieces. About 12 made beginning in 1990. A few more made in 1997 of 0.800 stock in two contrasting fancy woods.

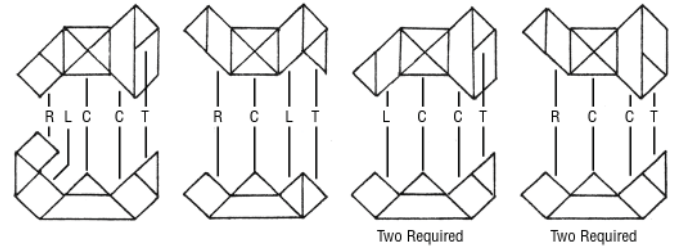

Star-of-David, Improved (#37-A) in cocobolo by Lee Krasnow

38 Three-Piece Block

Three pieces made of ten cubic blocks interlock to form a triangular pyramid. Surprisingly confusing. First 300 made of cherry for Citibank in 1980. About 50 more made starting in 1981, all of one-inch blocks.

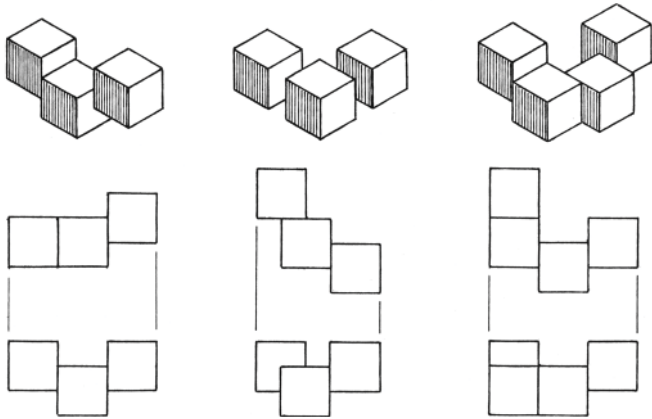

Three-Piece Block (#38) in padauk by Tom Lensch

39 Rosebud

Two kinds of pieces, three of each, assemble by coordinate motion with much difficulty to form an intriguing polyhedral solid. About 42 made, starting in 1982. Some were in mulberry and cherry. A deluxe version was made in Brazilian rosewood and tulipwood.

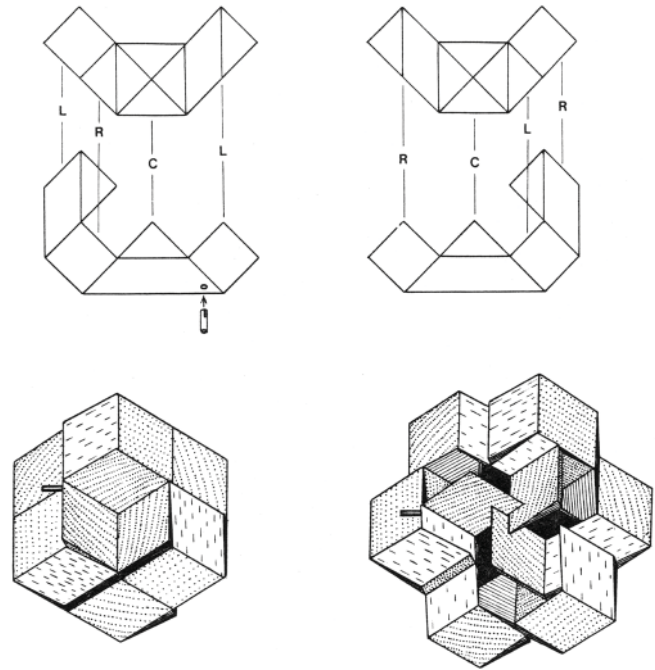

Rosebud (#39) in Brazilian rosewood & tulipwood by Stewart Coffin



Rosebud (#39) partially open, in Brazilian rosewood & tulipwood by Stewart Coffin

39-A Rosewood Assembly Jig

Made available later. **Rosebud (#39)** could conceivably be assembled without, but much easier with.



Rosebud Assembly Jig (#39-A) by Stewart Coffin

40 Interrupted Slide

A standard six-piece burr with either one or two solutions, depending upon the length of the pieces. Made 28 of the short version in 1982 of golden bilinga.

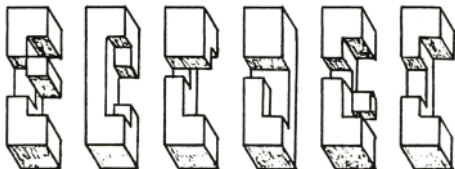

41 Unhappy Childhood

Ten checkered pieces, each made of five cubic blocks joined different ways, pack into a 5x5x2 square box. About 50 made in 1983-1984.

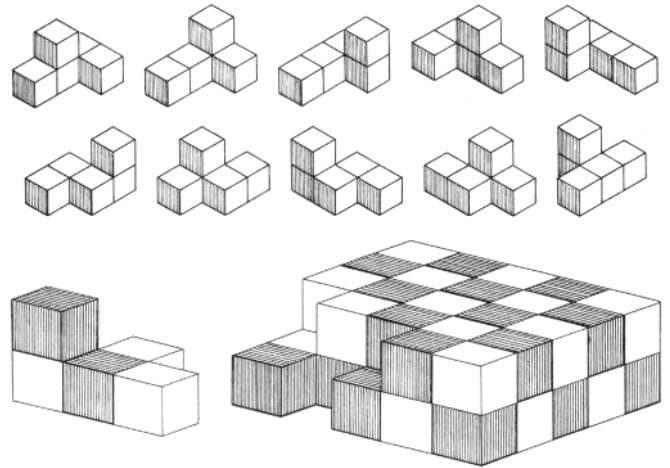

Unhappy Childhood (#41) in rosewood & satinwood by Stewart Coffin

42 Seven Woods

Six identical simple pieces make a modified diagonal burr. About 20 made in 1971. So named because seven kinds of wood were used in the fabrication of this novelty.



Seven Woods (#42) in pao ferro, Macassar ebony, Brazilian kingwood, cocobolo, dense Cambodian rosewood & oily bocote by Lee Krasnow



Seven Woods (#42) expanded

42-A Brickyard

A derivative of **Seven Woods** (#42), distorted by compression along the vertical axis. Only two made. Proposed as a possible exchange puzzle in 1996 but never used, and probably just as well. Too simple.

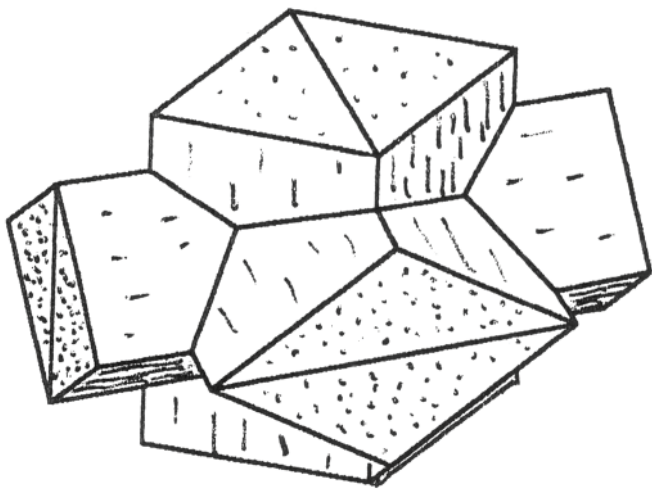

Brickyard (#42-A) by Stewart Coffin

43 Sleeper-Stopper

Topological—see *Puzzle Craft* 1985.

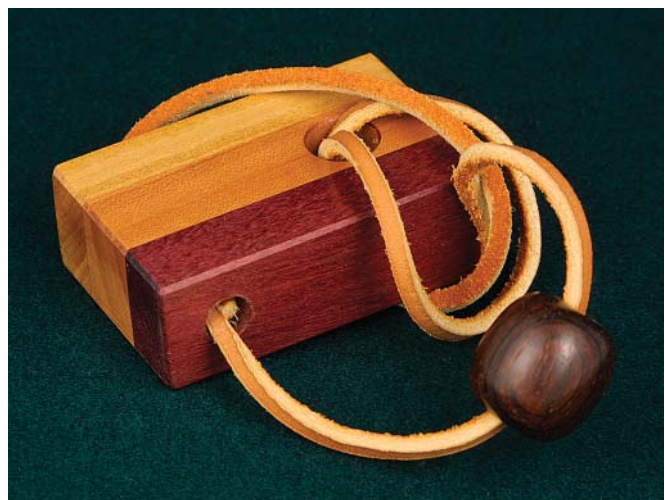

Sleeper Stopper (#43) in purpleheart, cherry & satinwood with rosewood bead by Stewart Coffin

44 Super Sleeper-Stopper

Topological—see *Puzzle Craft* 1985.



Super Sleeper Stopper (#44) in purpleheart, cherry & satinwood with rosewood bead by Stewart Coffin

45 Buttonhole

Topological—see *Puzzle Craft 1985*.

46 Vega

Six simple identical pieces assemble easily to form an attractive solid. About 30 in fancy woods sold at craft shows, 1972-1975.

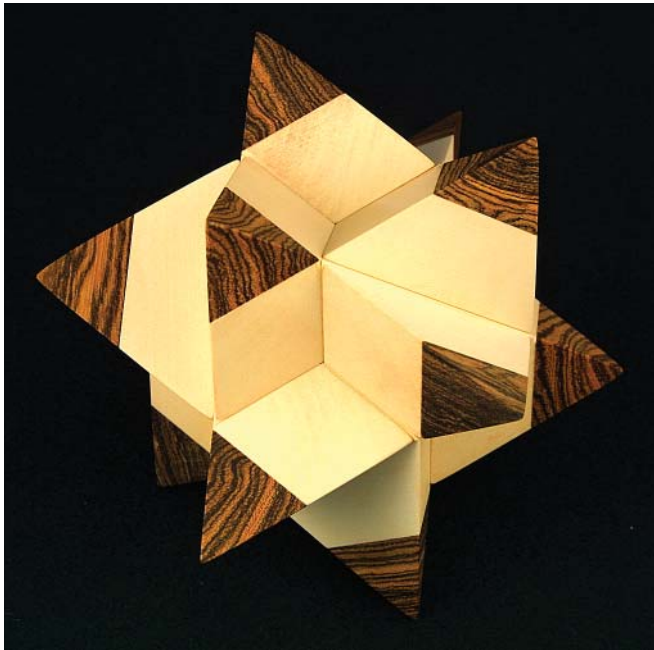

Vega (#46) in holly & bocote by Bart Buie

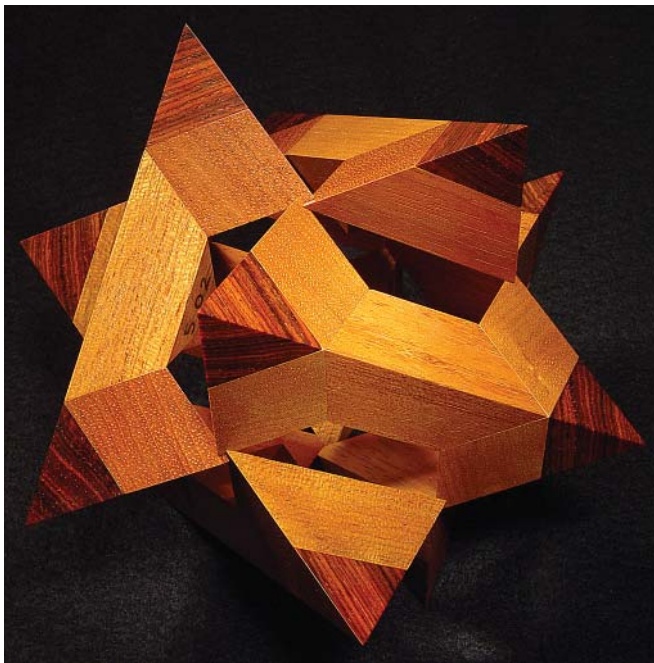

Vega (#46) expanded to its limits, in jatoba & cocobolo by Lee Krasnow

46-A Vega II

Same shape as **Vega** (#46) but made by truncating **Superstar** (#50).

47 Cluster-Buster

Six identical pieces assemble into a polyhedral solid, but harder to disassemble. About five made in 1973.

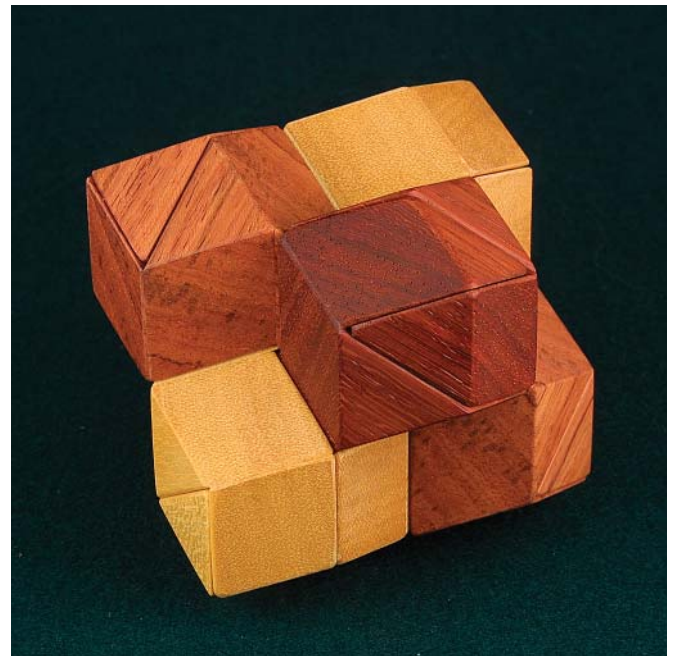
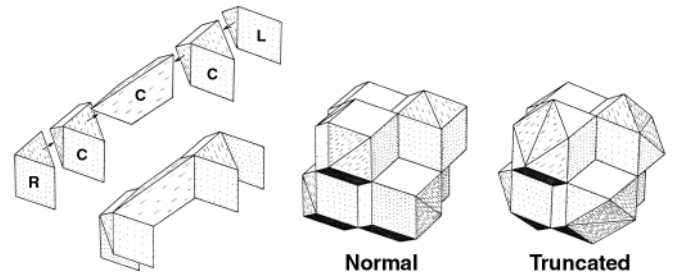

Cluster-Buster (#47) in Brazilian satinwood, bubinga & padauk by Tom Lensch

48 Truncated Cluster-Buster

Made by truncating **Cluster-Buster** (#47). About five made in 1973.



Truncated Cluster Buster (#48) in Santos rosewood, Honduras rosewood & gonalco alves by Lee Krasnow



Truncated Cluster Buster (#48) partially disassembled

49 Improved Cluster-Buster

About 10 made in 1973. When I hurriedly put together the first edition of AP-ART in time for distribution at IPP-20, this design was listed as “unpublished.” Translated, that means that I could not locate any drawings of the design to copy and paste in, either from *Puzzle Craft* 1985, *Puzzle Craft* 1992, *The Puzzling World of Polyhedral Dissections*, my file of instruction sheets, or any other resources. Evidently the plans were never recorded on paper. In such cases, I would instead retain at least one working model to copy, in case I should wish to make more. In this particular case, I find that I had either sold or discarded my last remaining **Improved Cluster-Buster**, so for the sake of com-

pleteness I have been forced to reinvent it. The plans shown may or may not be exactly the same as the original **Improved Cluster Buster**, but no matter, they will serve the purpose. The essential feature is three dissimilar pairs of pieces, hence a more interesting design, both to assemble and disassemble.

As in all of the **Cluster-Buster** family of designs, the framework of each piece consists of three six-sided center blocks joined together, onto which the right-hand and left-hand prism blocks are added, shown here shaded. Two of each piece required.

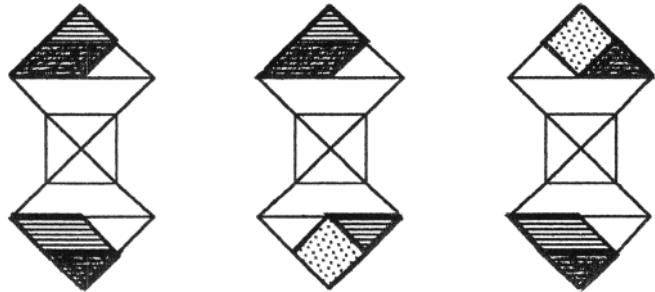

Improved Cluster-Buster (#49) in canarywood by Tom Lensch

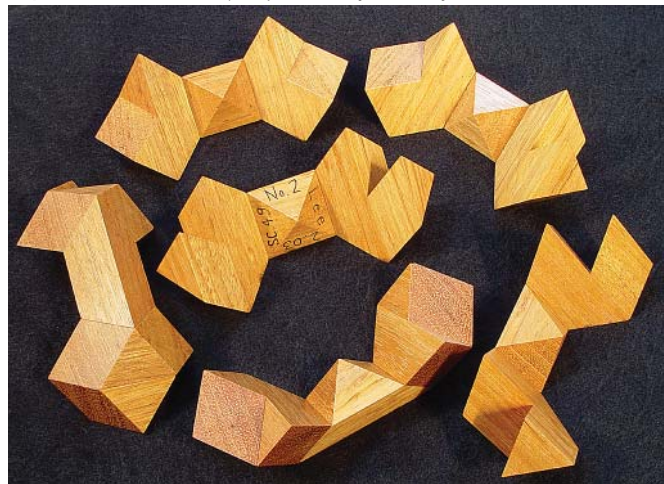

Improved Cluster-Buster (#49) pieces, in Jatoba by Lee Krasnow

50 Superstar

Six identical pieces assemble easily to form the third stellation of the rhombic dodecahedron. Does not quite live up to its name. More of a sculpture than a puzzle. About ten made in mahogany and sold at craft fairs, 1972-1975.

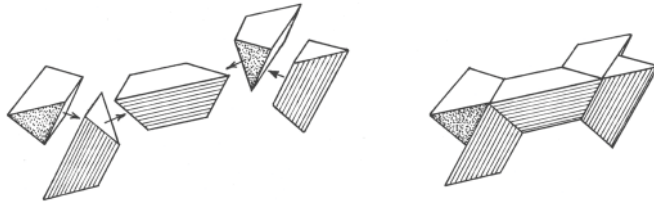

50-A Superstar II

A minor variation of the **Superstar** (#50). One made in 1990.

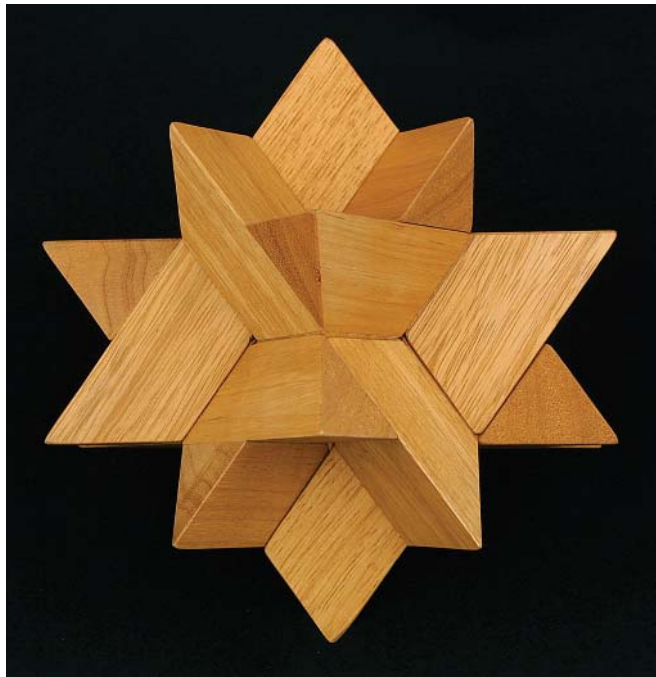

Superstar II (#50-A) in Honduras mahogany by Stewart Coffin

50-B Third Stellation

The **Superstar II** (#50-A) in four colors, proposed but never made—by me. See *The Puzzling World of Polyhedral Dissections*, page 88.

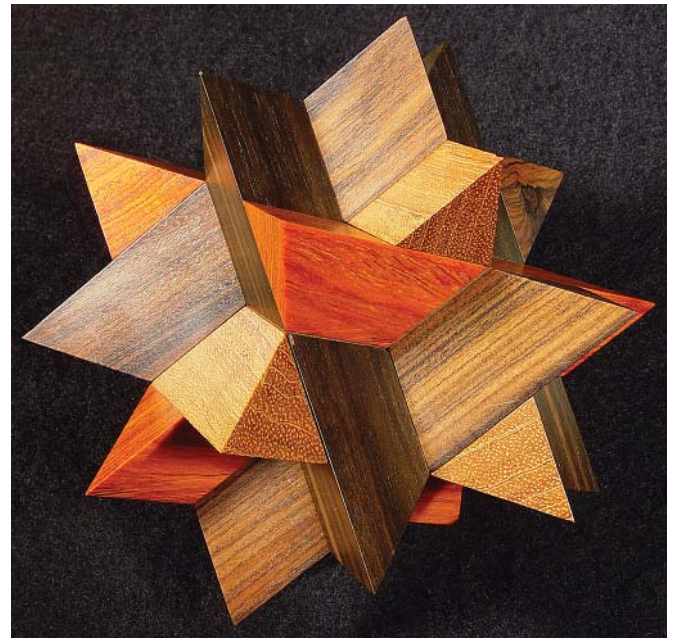
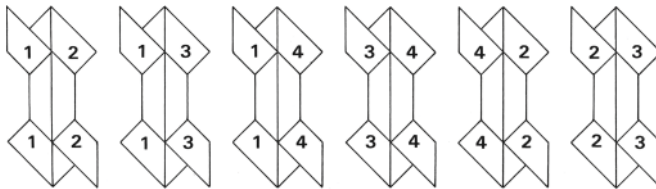

Third Stellation (#50-B) in jatoba, Macassar ebony, Panama cocobolo, pao ferro & Santos rosewood by Lee Krasnow



Third Stellation (#50-B) partially disassembled

51 Little Superstar

Simply a truncated version of **Superstar** (#50). Six identical pieces make the second stellation of the rhombic dodecahedron. Just a sculpture.

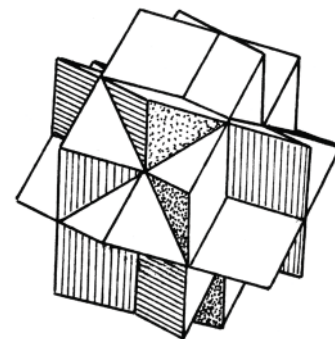

52 Pennyhedron

In the original **Pennyhedron**, two mirror-image halves mate to form a rhombic dodecahedron. Made about 150, 1971-1985. There was also a smaller version called **Minihedron**. Later there were variations too numerous to mention.

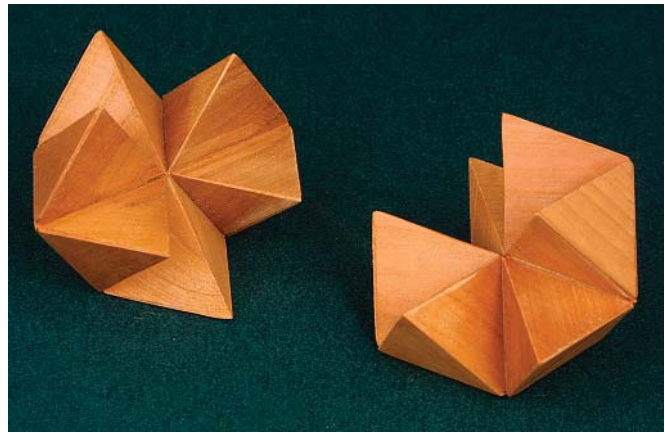
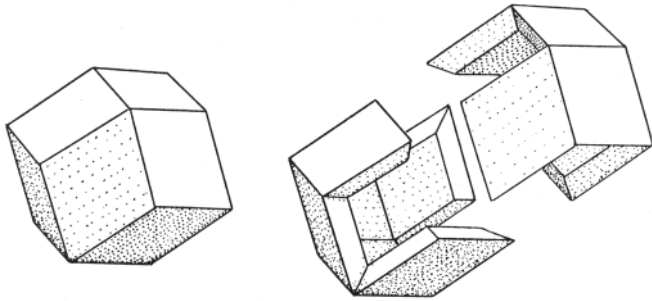

Pennyhedron (#52) pieces



Pennyhedrons (#52) by Lee Krasnow



Minihedrons (#52) by Stewart Coffin



Pennyhedron (#52) in cherry by Stewart Coffin

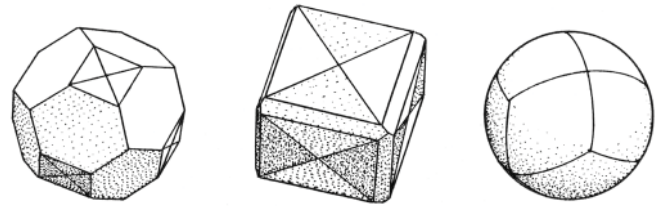

The three dissimilar pieces of the **Three-Piece Pennyhedron** are shown below. If made of three dissimilar woods, the correct grasp for disassembly can be deduced by examination. Otherwise it can be quite confusing to disassemble.

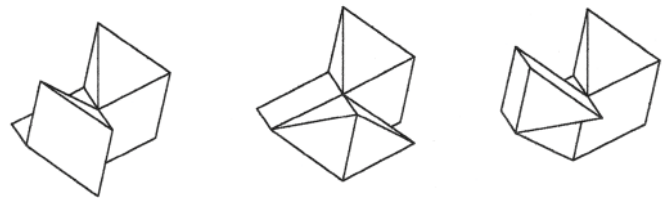

On the left in the following drawing, the **Zig-Zag Pennyhedron** is shown assembled, with the heavy line indicating the dissection that separates it into two identical halves.

On the right, a standard **Pennyhedron** has been sanded down to change its shape from a rhombic dodecahedron to an octahedron, producing interesting sculptural patterns of the three contrasting woods.

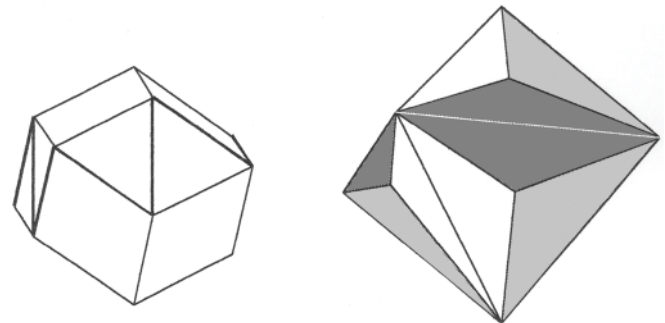

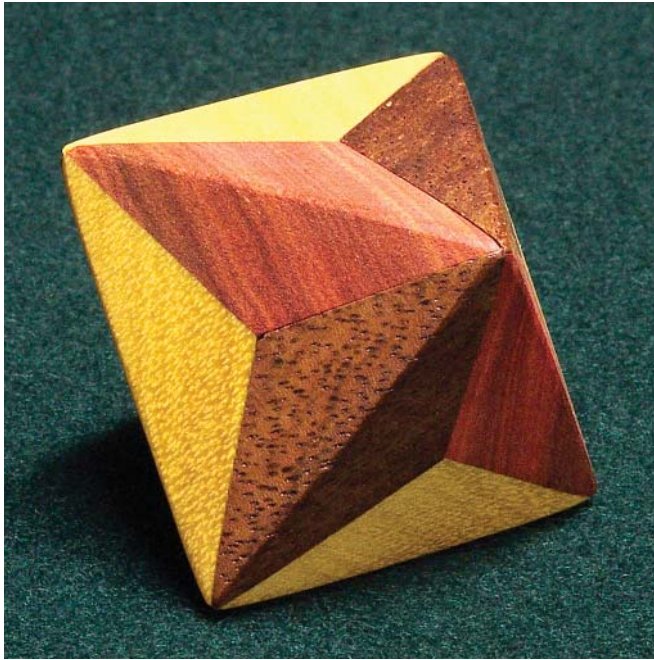

Pennyhedron (#52) sanded from a rhombic dodecahedron into an octahedron, in yellowheart, redheart & Honduras rosewood by Bart Buie

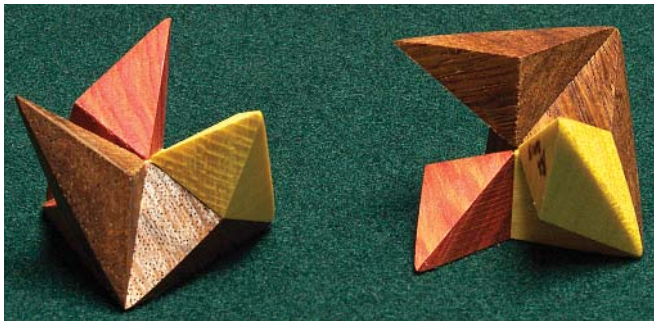

Pennyhedron (#52) pieces

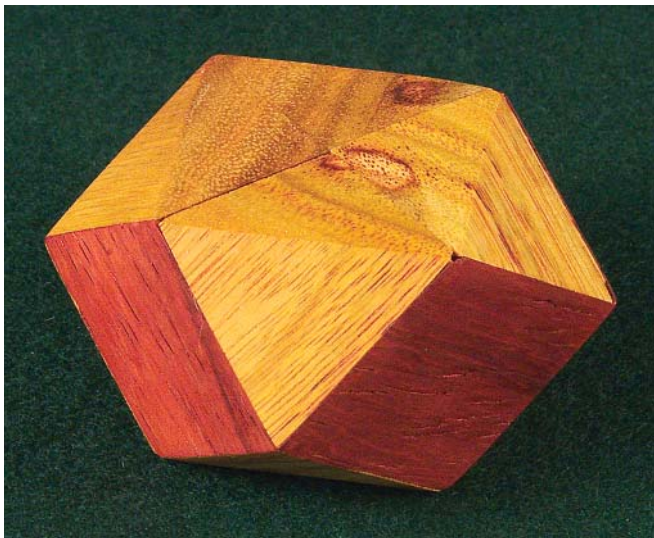

Pennyhedron (#52) truncated from a rhombic dodecahedron, in canarywood & padauk by Bart Buie

52-A Hole-in-One

Previously unpublished design, proposed for IPP puzzle exchange but never used. The three pieces are identical except that one has a pin and one has a hole. It assembles easily to form a rhombic dodecahedron but is surprisingly tricky to take apart. Four made in 1995.

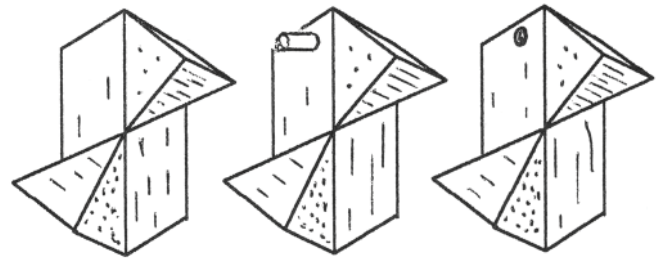

52-B Button Box

A distorted **Pennyhedron** having the symmetry of a brick. Used in the IPP-16 puzzle exchange.



Button Box (#52-B) by Stewart Coffin

52-C Pennyhedron Tricky Pair

A pair of Pennyhedrons that look alike but come apart different ways. See explanation in *Puzzle Craft 1985* or *The Puzzling World of Polyhedral Dissections*.

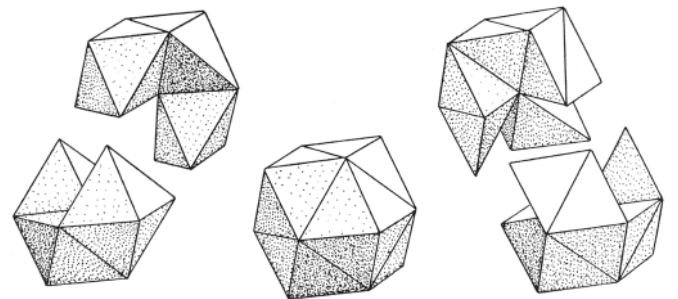

53 Little Giant Steps

This is an uninteresting variation of **Giant Steps** (#10) in which the added blocks are cubic instead of $1 \times 1 \times 2$. About three made in 1973.

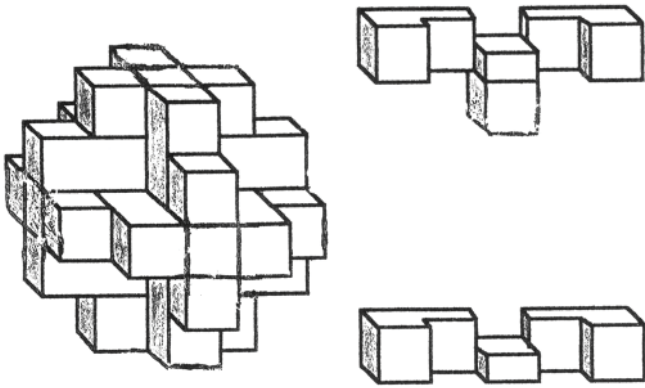

Little Giant Steps (#53) in mahogany by Bart Buie

54 Defiant Giant

This is a bizarre variation of **Giant Steps** (#10), same assembled shape, in which the added blocks are attached differently, as shown. The first piece is a standard **Square Knot** (#9) piece of length 5, six required. The second piece has a $1 \times 1 \times 1.5$ block attached. All the other attached blocks are $1 \times 1 \times 2$. Three required of piece on right, one each of the other three. Very tricky to assemble. One made in 1973.

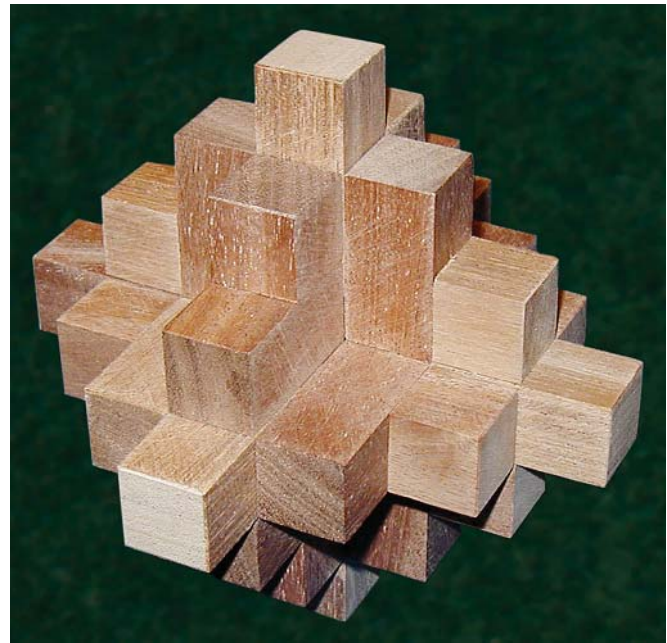
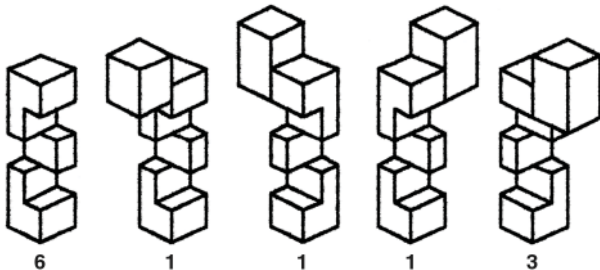

Defiant Giant (#54) in mahogany by Bart Buie

55 Pagoda

Eight cubic blocks are added to standard **Square Knot** #9 pieces, resulting in three kinds of pieces, four of each, as shown. Slightly trickier than the standard **Square Knot** to assemble. A few made in 1973.

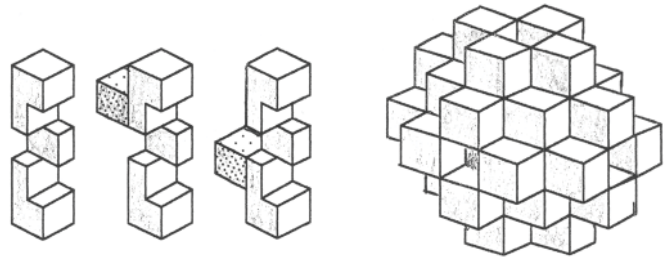

Pagoda (#55) in mahogany by Bart Buie

56 Giant Pagoda

This version is a combination of the six added blocks of **Giant Steps** (#10) and the eight added blocks of **Pagoda** (#55). This results in six kinds of pieces, two of each. This is another one of those lost designs. One or two made in 1973, and I have reconstructed this from memory. I hope I got it right.

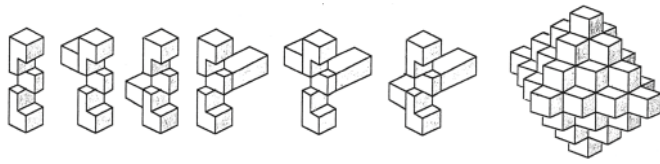

Giant Pagoda (#56) in mahogany by Bart Buie

57 Plus 2

This was my name given to the 14-piece version of the **Square Knot** (#9). See *Puzzle Craft 1985* for the amusing story of its discovery, and of the many variations. I also made a few larger assemblies such as the 24-piece and 36-piece versions shown here.

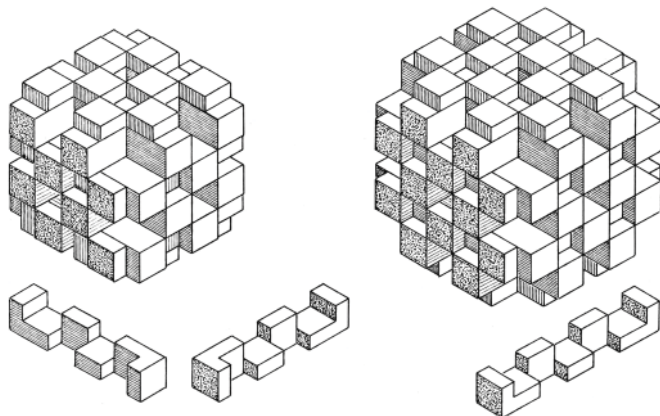

58 Diagonal Cube

Six dissimilar non-symmetrical pieces in two contrasting woods assemble diagonally to form an attractive cube. About 20 made in fancy woods, 1981-1985.

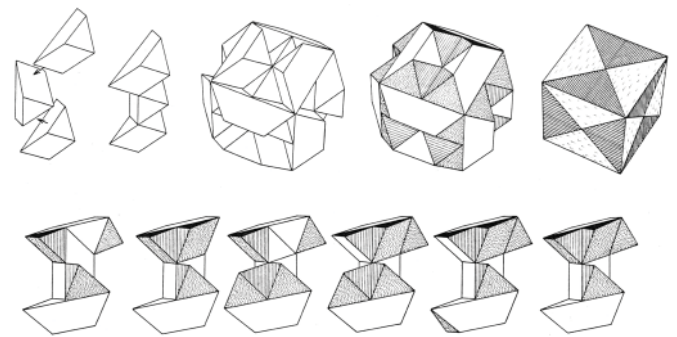

Diagonal Cube (#58) in cherry & Brazilian rosewood by Stewart Coffin



Diagonal Cube (#58) in cherry & Honduras rosewood by Stewart Coffin

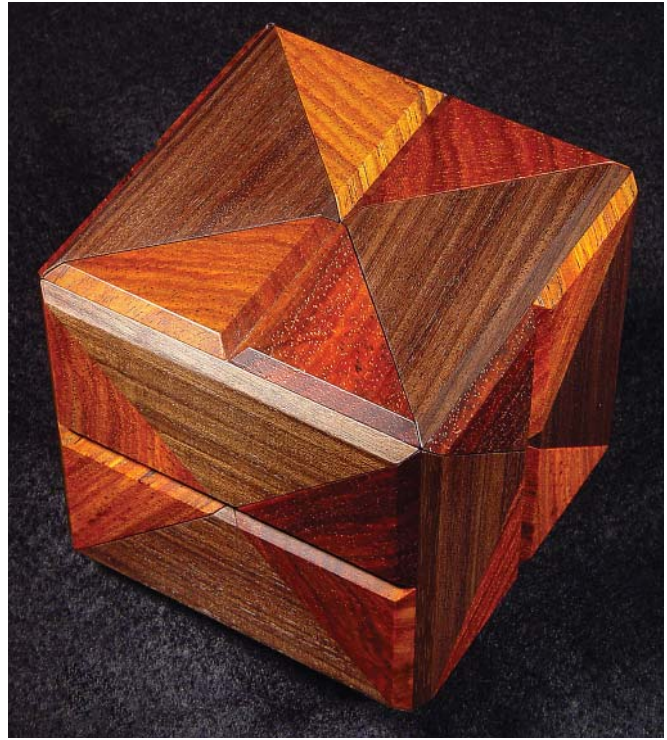

Diagonal Cube (#58) in dense Cambodian rosewood and Bolivian rosewood by Lee Krasnow



Diagonal Cube (#58) in Honduras rosewood & canarywood by Lee Krasnow

Note the differences in edge beveling in the three **Diagonal Cubes** shown.

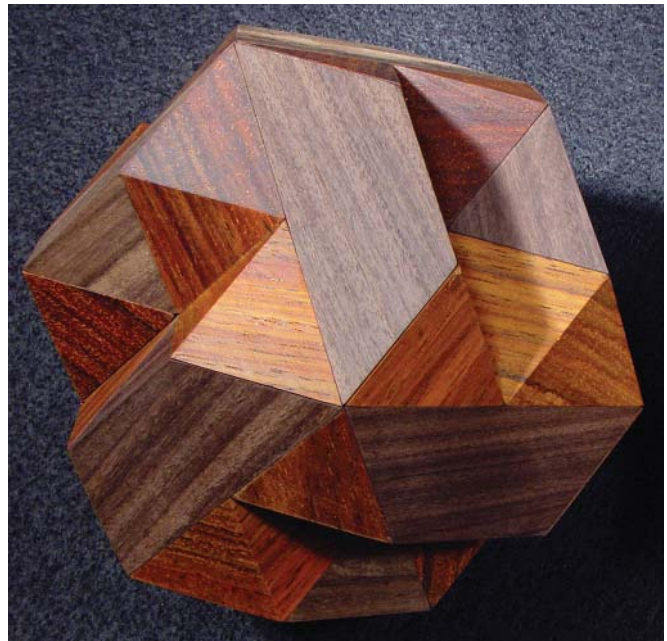

Same **Diagonal Cube (#58)** before truncation

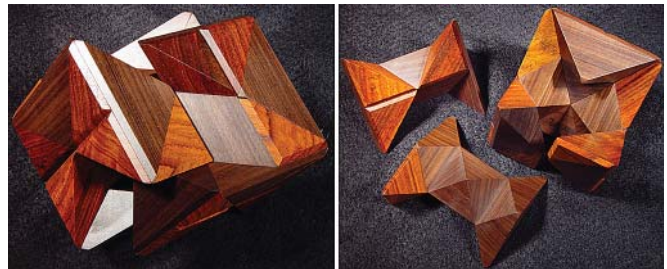

Same **Diagonal Cube (#58)** showing two halves sliding apart and partially disassembled

59 Corner Block

A **Pin-Hole** (#20) with eight cubic blocks added to the corners. Made about 30 starting in 1980 until superseded by the **Improved Corner Block** (#59-A).

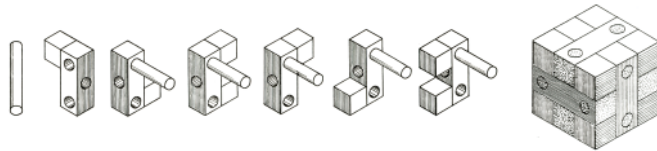

59-A Improved Corner Block

Designed in 1985 to replace **Corner Block** (#59). About 15 made.

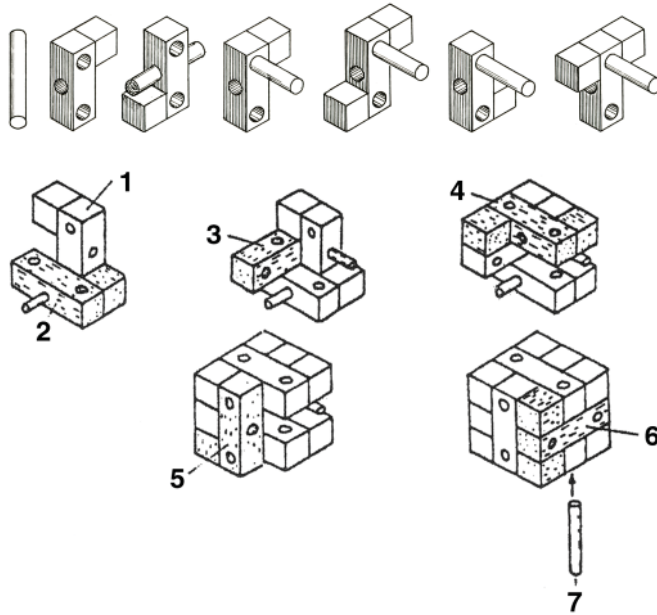

Improved Corner Block (#59-A) in Honduras mahogany & Brazilian rosewood by Stewart Coffin

60 Garnet

Six dissimilar pieces, each made of four tapered blocks, assemble into a rhombic dodecahedron. Appeared on 1984 brochure. About 30 made.

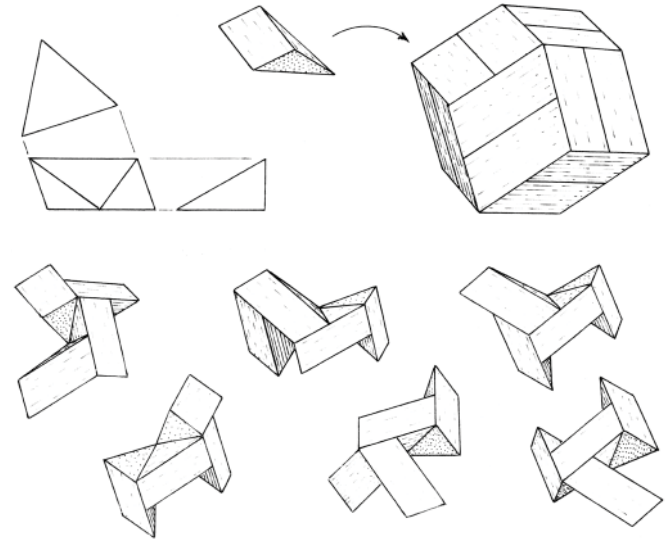

Garnet (#60) in ebony, tulipwood, purpleheart & three other unknown woods Stewart Coffin

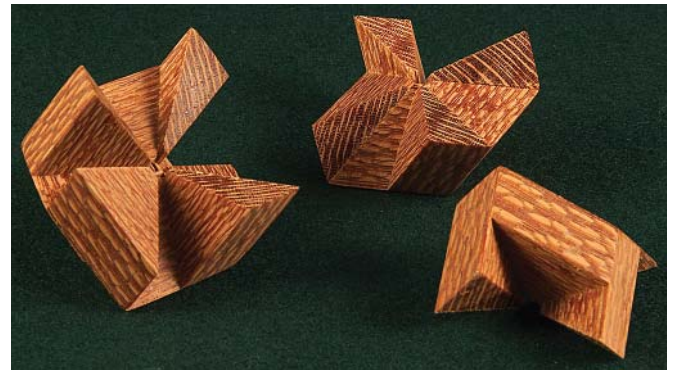

Garnet (#60) partially disassembled, in fishtail oak by Bart Buie

61 Setting Hen

Four pieces made of 14 rhombic dodecahedron blocks fit into a cubic box and construct other problem shapes. Appeared on 1984 brochure. About 30 made, but there are several better choices, including **Pyracube** (#19) and **Distorted Cube** (#61-A). See instruction sheet for details. The puzzle pieces, which are not defined on the instruction sheet, are shown here.

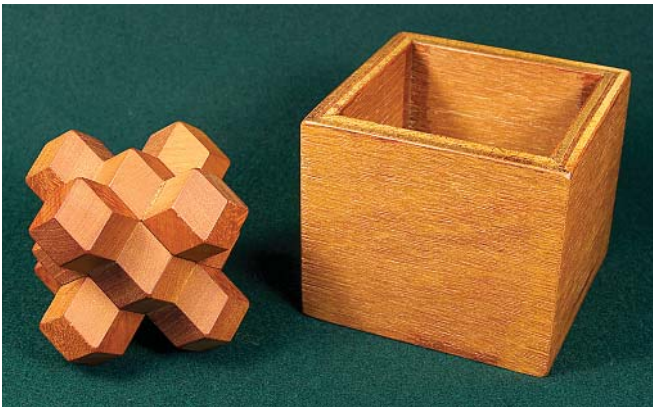
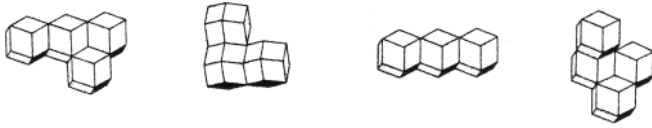

Setting Hen (#61) by Stewart Coffin

61-A Distorted Cube

A redesign and improvement of the **Setting Hen** (#61), made instead with edge-beveled cubes. Tricky box converts from cubic to rectangular. Designed in 1988. About 20 made.

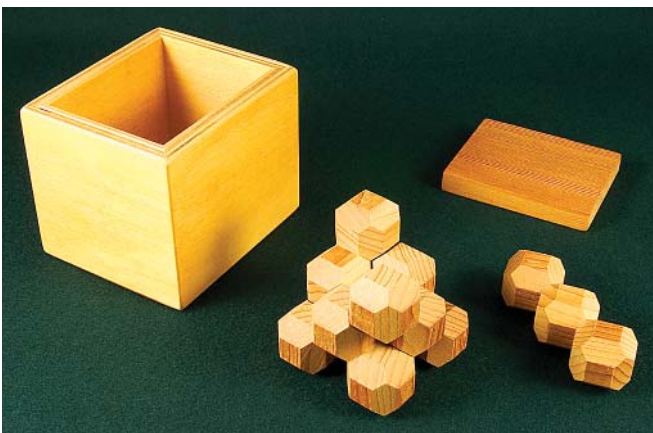
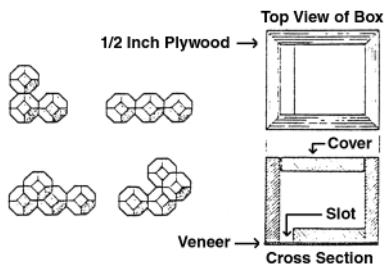

Distorted Cube (#61-A) in spruce with Baltic birch box by Stewart Coffin

62 Nine Bars

Same idea as **Cuckoo Nest** (#21) but nine bars and dowels rather than six, and three layers instead of two. Only one solution known—difficult. Appeared on 1984 brochure. About 10 made in birch.

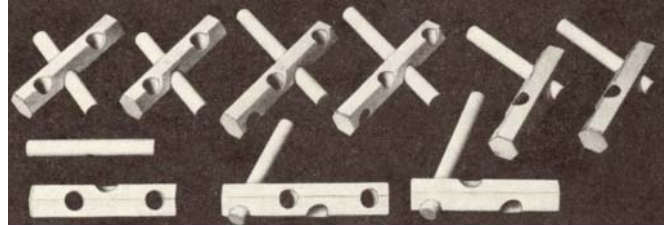

Nine Bars (#62) in birch by Stewart Coffin

63 Pseudo-Notched Sticks

A novelty of six identical pieces. Looks like ordinary diagonal burr, but when you try to disassemble all you are doing is pressing it more tightly together.

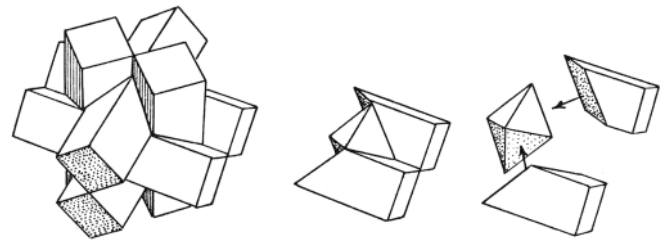



Pseudo-Notched Sticks (#63) in tulipwood, Santos rosewood, Macassar ebony, goncalo alves, Panama cocobolo & Brazilian kingwood by Lee Krasnow



Expanding Box (#64) in Honduras rosewood by Stewart Coffin



Pseudo-Notched Sticks (#63) partially slid apart.

64 Expanding Box

Just a novelty. Six identical pieces fly apart. Coordinate motion, requires some dexterity to reassemble. Two made of Honduras rosewood in 1971.

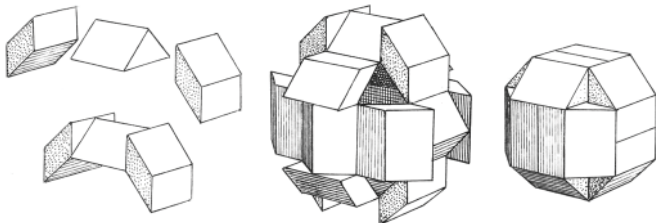

65 Thirty Notched Sticks

In my file of design ideas for 1972, I list a rhombic version and a couple of pentagonal versions. My rough models of the latter are shown plus a triangular stick version. More information is in *The Puzzling World of Polyhedral Dissections*, pages 136-137.

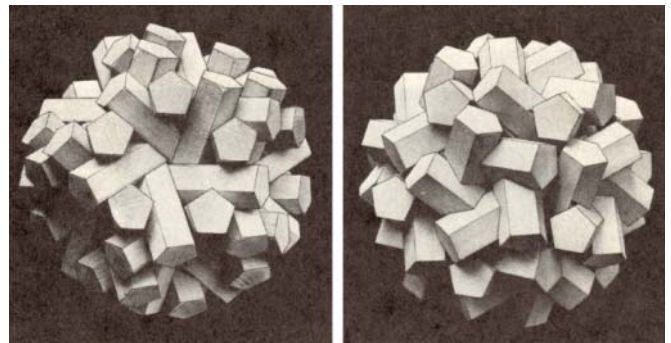

Thirty Notched Sticks (#65) triangular sticks, in cast epoxy by Stewart Coffin

65-A Thirty Notched Rhombic Sticks

This was the only version found to be practical. A few of these were finally made in mahogany in 1987.



Thirty Notched Rhombic Sticks (#65-A) in southern yellow pine by Stewart Coffin

66 Crystal Blocks

This is the label that I attached to various sets of puzzle pieces consisting of rhombic dodecahedral blocks cast in epoxy and joined together different ways. This was back in 1971 when I was still attempting to cast in thermosetting resins. The one set of six that was most thoroughly analyzed for recreational constructions is shown here. I still have all the notes if anyone is interested in pursuing this.

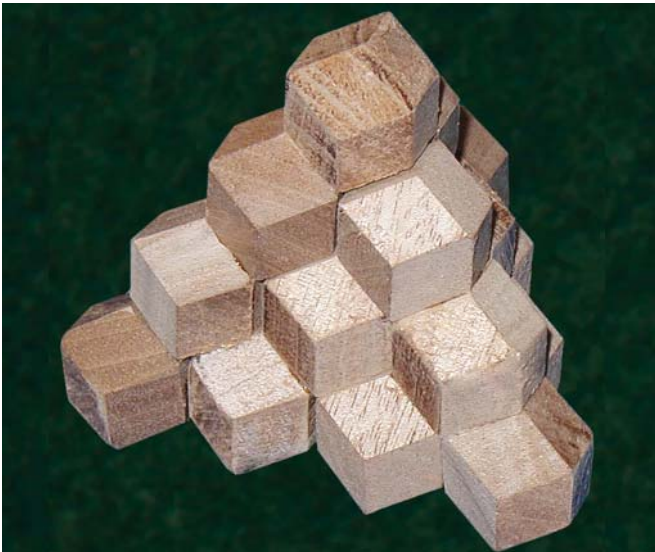
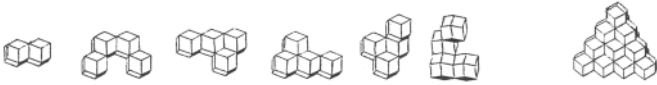

Crystal Blocks (#66) in Philippine mahogany by Stewart Coffin

67 Peanut

Six polyhedral pieces fit together many ways to construct various shapes shown on the instruction sheet. Designed in 1973 for possible manufacture in plastic, but never done. Resurrected in 1986 to make in wood. Made about 30 sets of one-inch mahogany. A neat puzzle. Requires accurate woodcraft but otherwise not difficult to make.

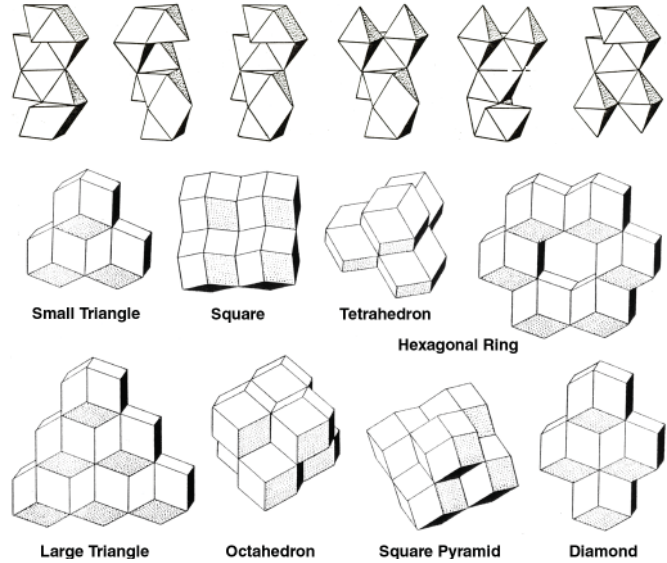

Peanut (#67) assembled in "small triangle" configuration



Peanut (#67) assembled in "Tetrahedron" configuration



Peanut (#67) pieces



Peanut (#67) assembled in "Square" configuration

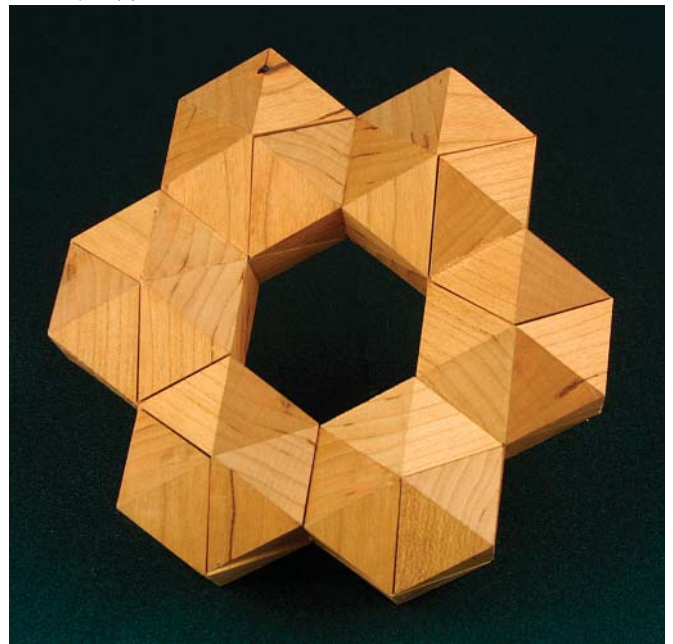

Peanut (#67) in cherry by Bart Buie

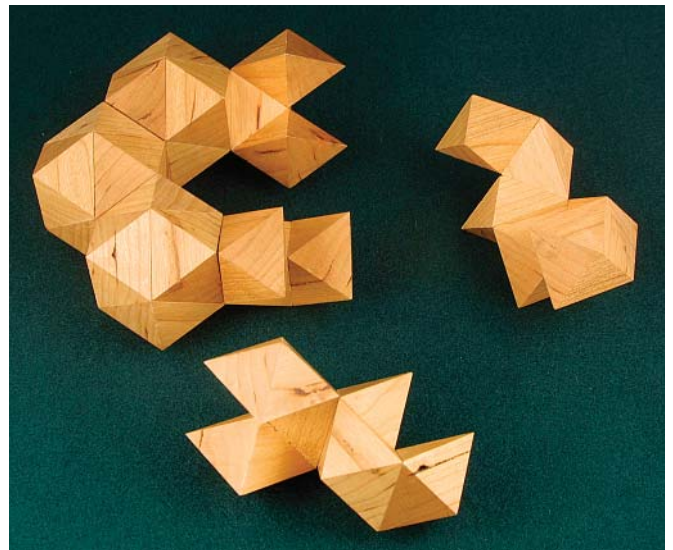

Peanut (#67) partially disassembled

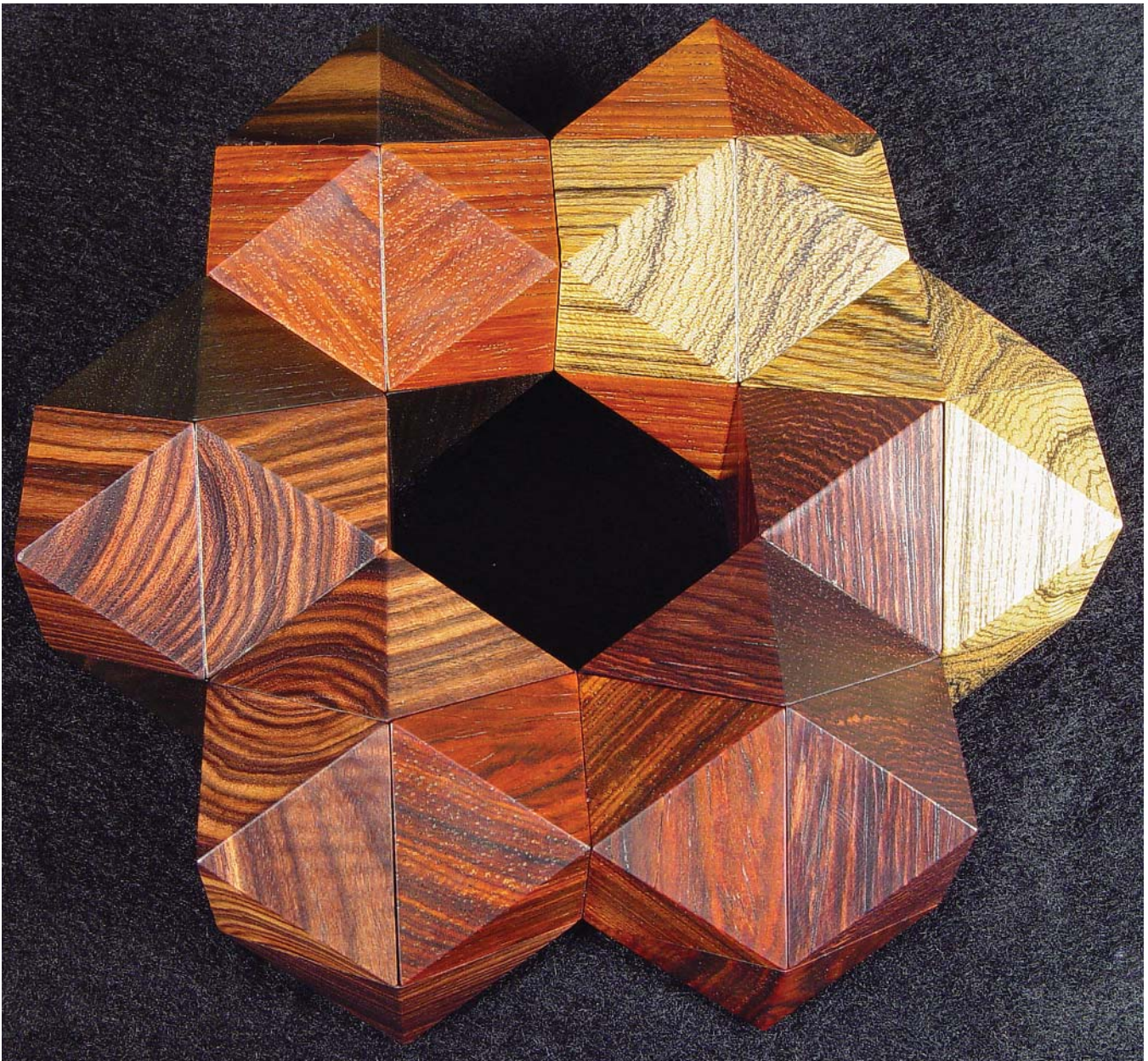

Peanut (#67) assembled in "hexagonal ring" configuration, in Mexican kingwood, Macassar ebony, Brazilian kingwood, cocobolo, dense Cambodian rosewood & oily bocote by Lee Krasnow

67-A Shatterblock

This is the same idea as **Peanut** (#67) except based on the three-prong bisection of the rhombic dodecahedron used in the **Pennyhedron** (#52). It was likewise conceived for manufacture in plastic, but never was. Designed in 1973 and never got beyond the design stage.

67-B Pennydoodle

This is the revised and improved version of **Shatterblock** (#67-A) designed for fabrication in wood. Five pieces fit together many different ways. About 30 made, 1989-1990. To be satisfactory they must fit precisely and not warp. They had a tendency to bind with age, so discontinued making.

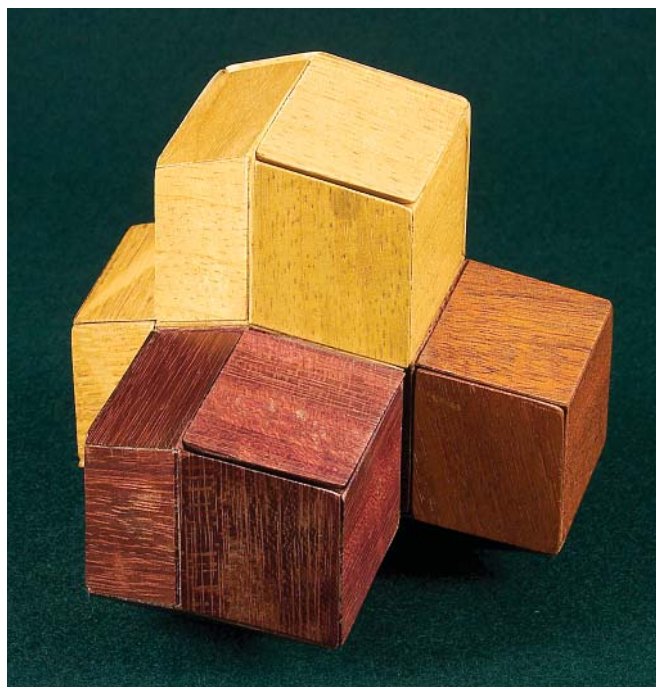
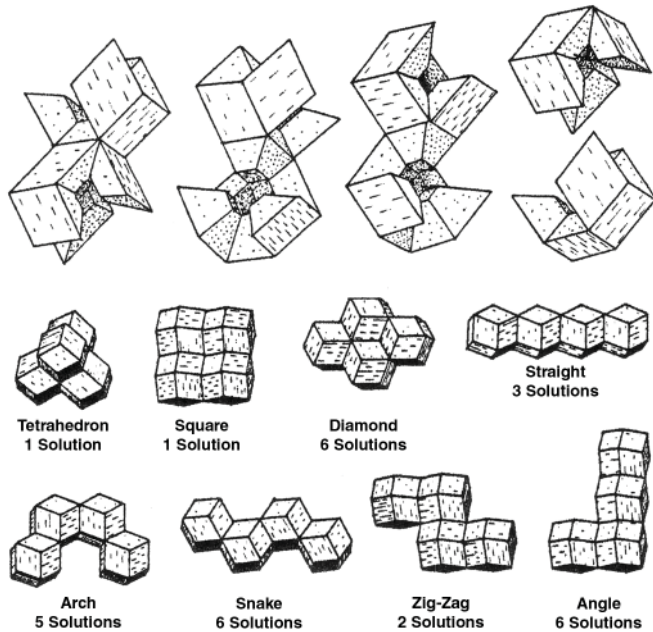

Pennydoodle (#67-B) assembled in "tetrahedron" configuration, in limba, oak, purpleheart & mahogany by Stewart Coffin

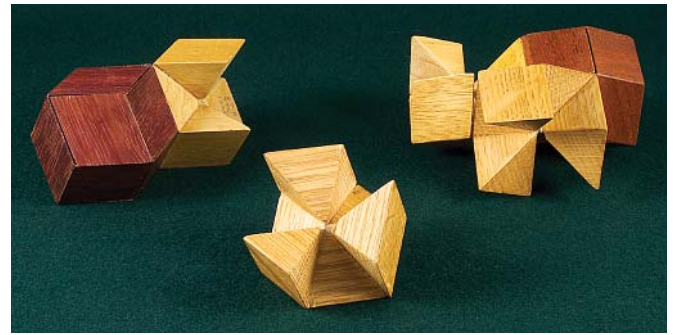

Pennydoodle (#67-B) partially disassembled

68 Confessional

A variation of **Square Knot** (#9) using $\frac{3}{4} \times 3$ -inch sticks of 85 degree rhombic rather than square cross section. Two kinds of pieces, 8 of one (labeled A) and 4 of the other (labeled B). Tricky solution involves rotation. Designed in 1994.

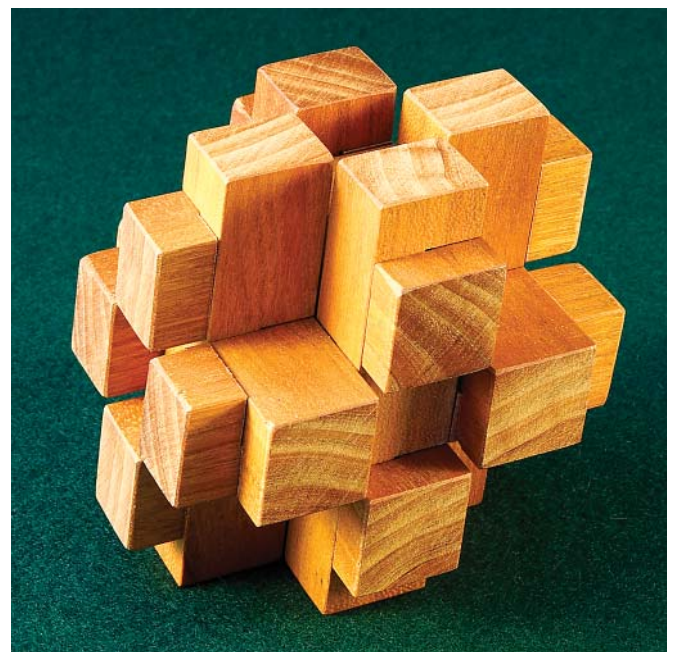
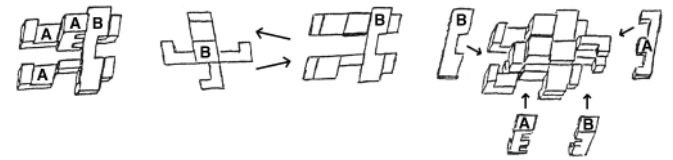

Confessional (#68) in cherry by Stewart Coffin

68-A Leaning Tower of Altekruise

A 14-piece variation of **Confessional, Long Version** (#68-B). Used in the IPP-15 puzzle exchange.

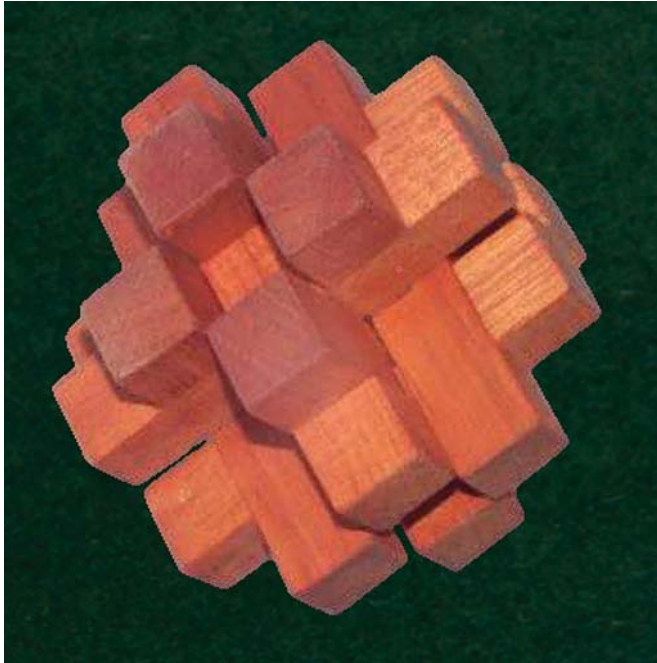

Leaning Tower of Altekruise (#68-A) in mahogany by Stewart Coffin

68-B Confessional, Long Version

Like the original **Confessional** (#68) except that sticks are five units long instead of four. Even more confusing. One of my most satisfactory designs, but only a few made because of the labor of sawing out the slant notches with multiple saw cuts. With a special cutter, would be easy to manufacture and perhaps well worth the investment.

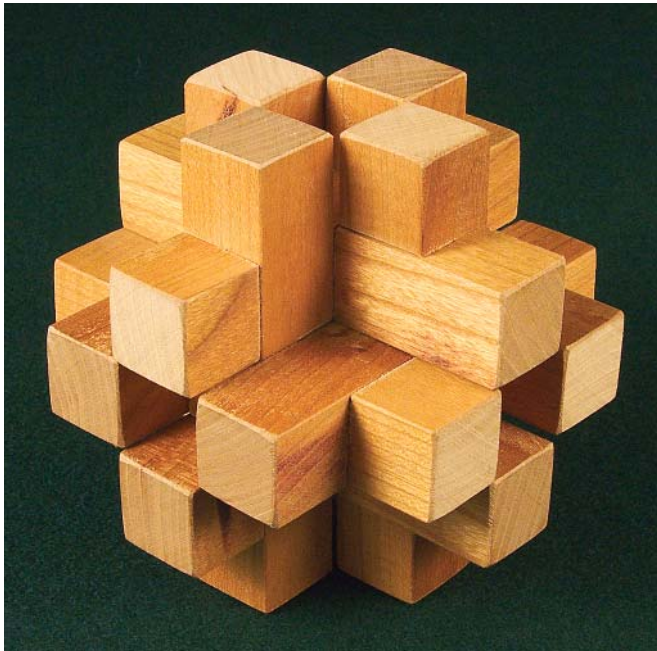

Confessional, Long Version (#68-B) in cherry by Stewart Coffin

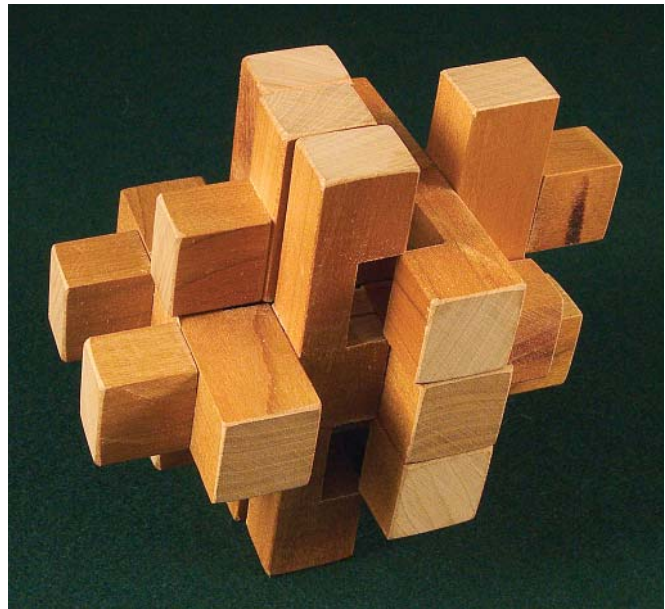

Confessional, Long Version (#68-B) partiality separated

69 No Name

This was to be a distorted version of **Scorpius** (#23) or **Jupiter** (#7) but never got beyond the preliminary design stage. Awaits some enterprising inventor and woodcrafter.

70 No Name

This was to be an improved **Saturn** (#24) with a unique solution, but the project was postponed and later named and re-numbered **Sphinx** (#156).

71 Stucksticks

Previously unpublished. Starts out with **Hexsticks** (#25-C) in four colors. That version used nine standard pieces and three odd (extra notch) pieces. In **Stucksticks**, four pairs of standard pieces are bonded together into T-pieces for greater challenge. Reported to be confusing, even with hints provided by the multi-colored woods arranged symmetrically. Designed in 1995 and three made, but superseded by **Sticky Sticks** (#140), **Seven-Piece Hexsticks** (#159), and finally **Seven-Piece Hexsticks, Improved** (#159-A).

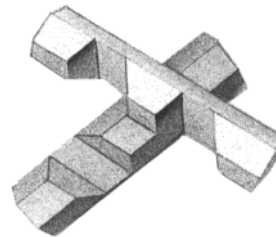

71-A Stucksticks

This was to be the same as **Stucksticks** (#71) but in all one kind of wood. Even more confusing. None made.

72 Design No. 72

Analogous to the **Garnet** (#60), but here the assembled shape is instead a 30-faced triacontahedron. Hence 60 identical wedge-shaped blocks bonded together to make five kinds of pieces, two of each. Each piece is a different kind of colorful wood, arranged for pleasing contrast in the assembly. The hollow shell goes together in two identical halves. The pieces are lettered internally for ease of assembly. More of an attractive wood sculpture than a puzzle. Six made in 1985.

The five dissimilar pieces for **Design No. 72** are shown by a schematic representation of their outside faces, approximately as they would appear when viewed along a five-fold axis of the assembled puzzle. Two of each are required. To assemble each half, refer to the letters, which indicate mated pairs of blocks. The two identical halves are then brought together to complete the assembly.

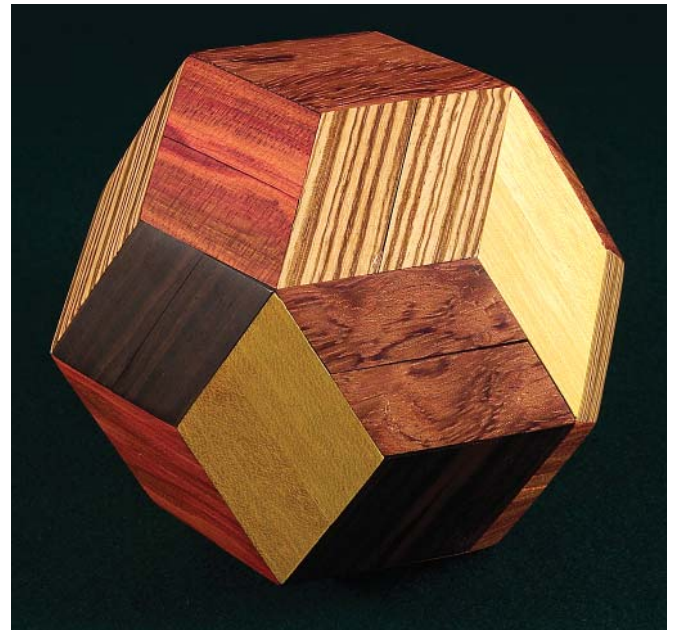
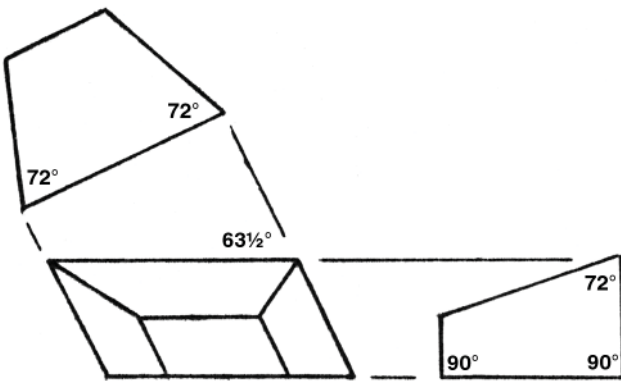
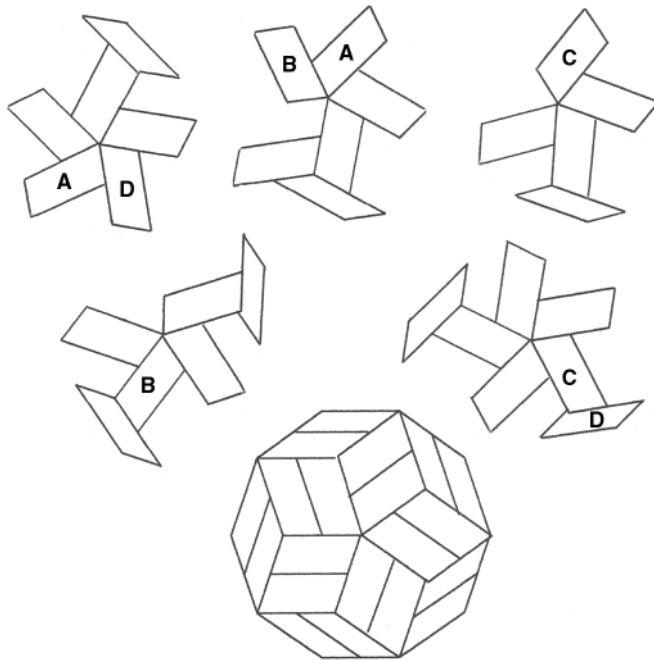

Design No. 72 (#72) in zebrawood, bubinga, Macassar ebony, tulipwood, redheart & yellowheart by Bart Buie



Design No. 72 (#72) halves separated



Design No. 72 (#72) one half disassembled except for two pieces on right

72-A Design No. 72, Two-Tiered Version

Very complicated to explain, not to mention illustrating. In the two-tiered version, the blocks of the outer shell are deeply truncated to make space for the inner layer. The blocks of the inner layer are also truncated because they are easier to make that way. One was made in 1990, but the design was unrecorded.



Design No. 72, Two-Tiered Version (#72-A) in Honduras mahogany, satinwood, sumac, purpleheart, tulipwood & rosewood by Stewart Coffin

73 Seven-Piece Third Stellation

All seven pieces are dissimilar and non-symmetrical. The first step of assembly involves tricky coordinate motion of three pieces. The remaining four steps are serially interlocking. Evidently designed around 1973 and forgotten until rediscovered in 1985. Five made in mahogany. A very satisfactory but a previously unpublished design. I hope the several hours it took to make this illustration was justified. The drawing accompanying **Seven-Piece Third Stellation, Modified** (#73-A) is anatomically correct but probably incomprehensible. If you want to make **Seven-Piece Third Stellation, Modified**, note that the two sets of pieces are nearly identical. To convert #73 into #73-A, just remove the end block on the key piece and add it to the piece that is second from the left.

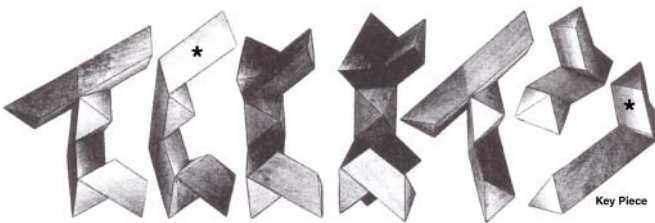

Seven-Piece Third Stellation (#73) in walnut by Stewart Coffin

73-A Seven-Piece Third Stellation, Modified

This is a slightly modified version of the **Seven-Piece Third Stellation** (#73) that is harder still, even though the use of four kinds of colorful woods arranged mutually parallel gives hints. Two of the pieces are identical in shape, and the key piece is a plain stick. The problem is that theoretically the puzzle is impossible to assemble, and the first step, which involves coordinate motion with rotation can be done only if the center vertices are slightly sanded down. It can range from difficult to nearly impossible depending upon the amount of removal. Designed in 1996 and a few made in fancy woods. The original version is the better design.

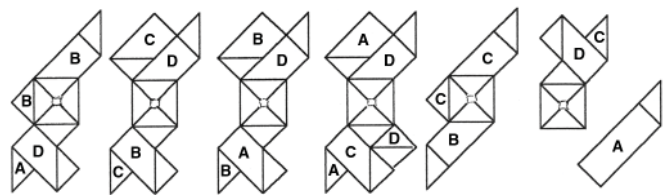

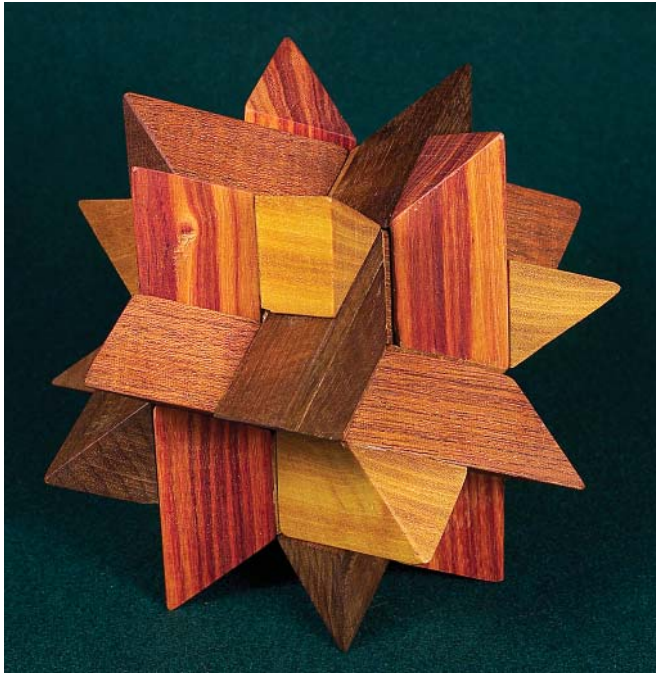

Seven-Piece Third Stellation, Modified (#73-A) in tulipwood, yellowheart, camphorwood & machiche by Stewart Coffin

74 Square Face

To the **Pseudo-Notched Sticks** (#63) twelve additional notched blocks are attached, making six dissimilar non-symmetrical pieces. There are two solutions. Made about 20, 1987-1988.

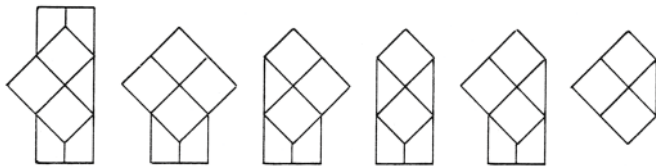
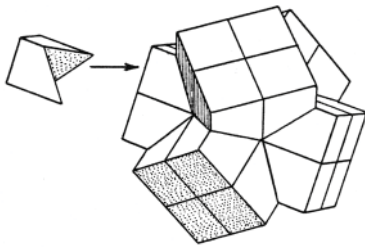

74-A Square Face, Improved

This version starts with the standard six-piece diagonal burr, to which the 12 notched blocks are added, again making six dissimilar non-symmetrical pieces. There is one solution, with minor variations, and it involves coordinate motion. A neat little puzzle if accurately made.

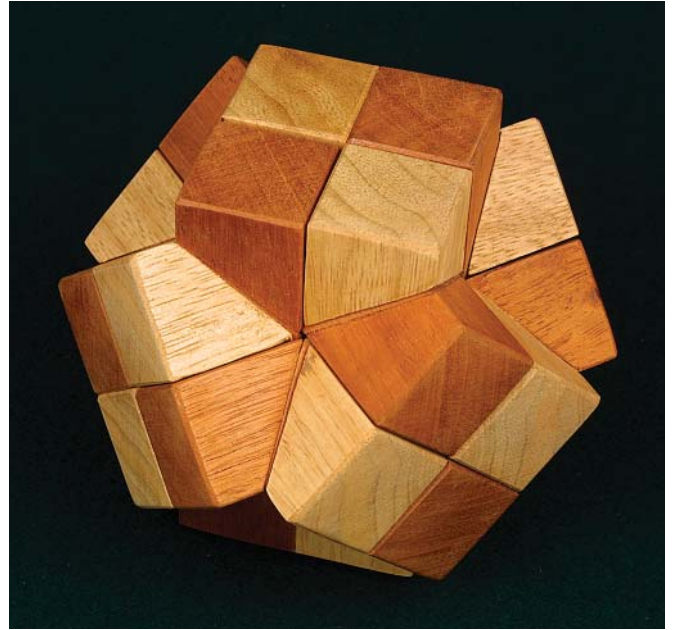
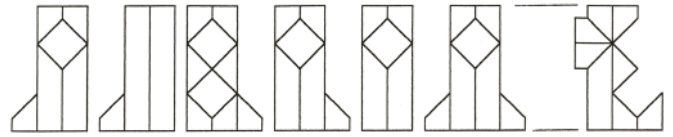

Square Face, Improved (#74-A) in Honduras mahogany & limba by Stewart Coffin

75 Split Star

A complicated two-tiered variation of **Garnet** (#60), with the outer layer forming the first stellation of the rhombic dodecahedron and the inner layer being basically a **Garnet** puzzle. Four made of applewood in 1985, one of my finer accomplishments in woodcraft.

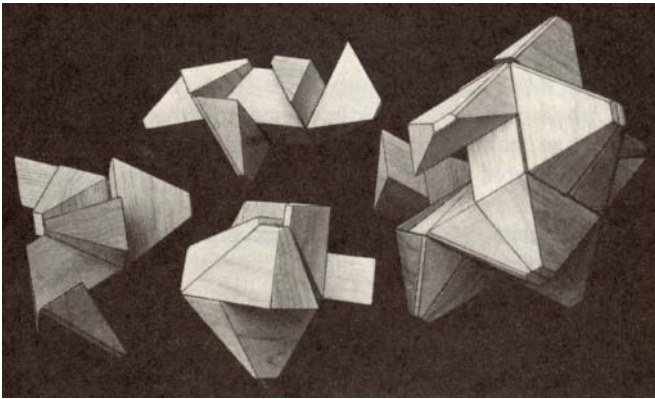

Split Star (#75) in applewood by Stewart Coffin

75-A Two Tiers

This is essentially a two-tiered **Garnet** (#60) puzzle, one inside the other. Designed and illustrated in 1988 but never made. A whole chapter of *The Puzzling World of Polyhedral Dissections* is devoted to it.

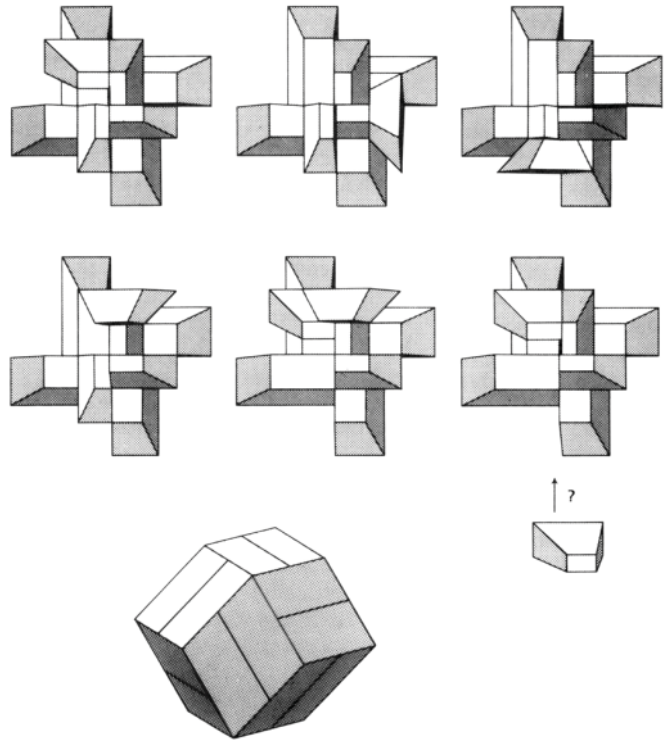

76 Cornucopia

This is a large family of designs that involve fitting ten hexominoes onto an 8x8 tray. Analyzed by Mike Beeler in 1985 by computer. It is fully described in *Puzzle Craft 1985*, *Puzzle Craft 1992* and *The Puzzling World of Polyhedral Dissections*. About 100 sets, all different, made 1985-1987.

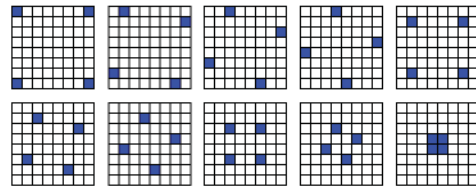
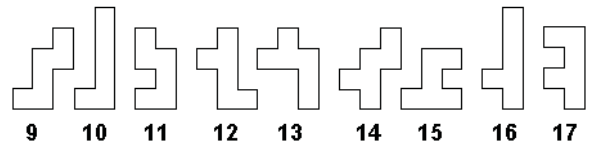
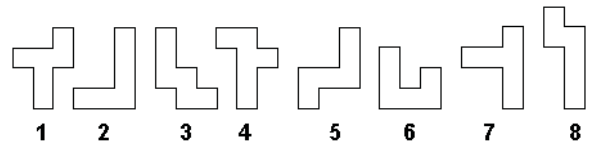



Cornucopia (#76) by Stewart Coffin



Cornucopia (#76) by Stewart Coffin

76-A Cornucopia 105747 a.k.a The Copious Cornucopia

Selected from among the 8203 possible usable sets for greatest versatility of solutions. About 30 made, 1985-1986, using ten contrasting fancy woods.

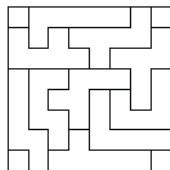

76-B Cornucopia 107715

Has a unique solution when a 1x1 square occupies the four corners and a unique solution when a 2x2 square occupies the center location. Used in the IPP-16 puzzle exchange.



Cornucopia 107715 (#76-B) solved with four 1x1 squares in the corners, in walnut & cherry by Walt Hoppe



Cornucopia 107715 (#76-B) solved with a 2x2 square in the center, in walnut & cherry by Walt Hoppe

77 Pieces-of-Eight

Eight dissimilar pieces join together different ways to construct a cube and eight other shapes. About 25 made, 1986-1988. The deluxe ones were in multi-colored woods with symmetrical grain patterns. I tried to get this entertaining novelty manufactured in plastic but was unsuccessful.

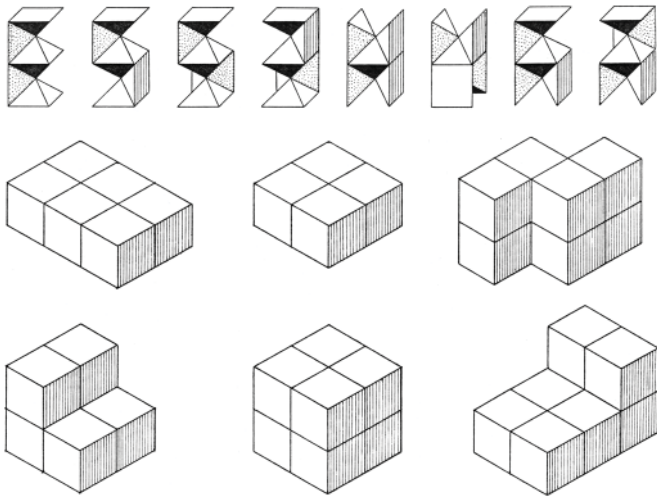

Pieces-of-Eight (#77) in birch with walnut box by Tom Lensch

78 Pillars of Hercules

Has the superficial appearance of just another dissection of the $3 \times 3 \times 3$ cube, but two of the five pieces come apart using the same joint as **Pieces-of-Eight** (#77), thus increasing the difficulty. For all that extra work, not a very neat design in my opinion. Two made in 1990.

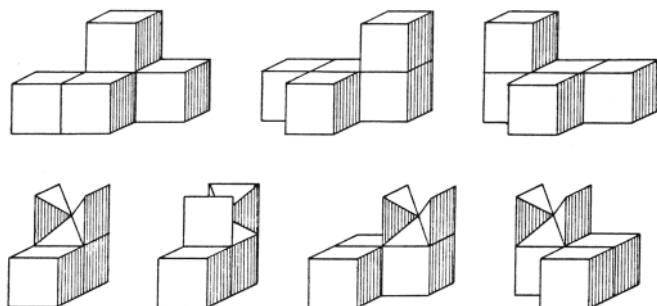

78-A Pillars of Hercules II

Similar to **Pillars of Hercules** (#78) except that three pieces all come apart, making it even more baffling. Furthermore, one of the pieces cannot be subassembled before insertion. Three made in 1990.

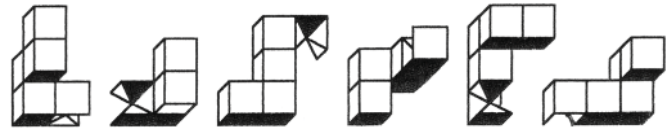

78-B Pillars of Hercules III

Another variation of **Pillars of Hercules** (#78) in which two of the pieces have swivel joints, made by using countersunk flathead screws, with the screw heads hidden by glue joints. Especially confusing if the joint is stiff and the puzzle solver does not realize that it has been turned to an impossible position. Two made in 1990. More recently I have made an improved version with just one swivel joint.

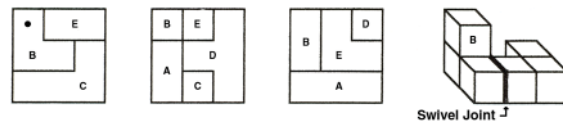

78-C Five-Piece Solid Block

Just another five-piece dissection of the $3 \times 3 \times 3$ cube. What makes it different from most is that if made accurately it tends to be interlocking, depending upon one's loose definition of that term. Two made in 1990, and three more in 2003 using five multi-colored woods.



Five-Piece Solid Block (#78-C) in Osage orange, Brazilian cherry, oak, poplar, purpleheart & maple with plywood box by Stewart Coffin

78-D Pretty Puzzle

Another ordinary five-piece dissection of the 3×3×3 cube. Less difficult than **Five-Piece Solid Block** (#78-C), but if made of colorful contrasting woods, attractive symmetrical patterns appear on all six faces.

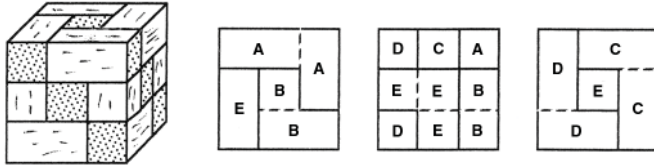

79 Triple Cross and HO HO

Twelve (**Triple Cross**) or fourteen (**HO HO**) identical pieces assemble in the familiar **Square Knot** (#9) configuration, but with a different type of joint. Two made in 1973 for the purpose of licensing for manufactured in plastic, but it never happened. Too bad. Would have made a neat puzzle. Probably too hard to be practical for making in wood. In the 14-piece version the shapes H and O appear on alternate faces, hence the name.

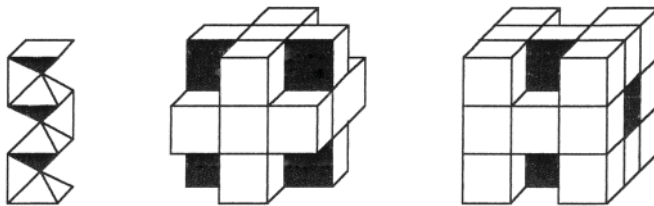

80 Thirty Pinned Pentagonal Sticks

This sculptural object uses 30 identical pentagonal sticks pinned together with 30 dowels in a sort of spherical cluster. Each stick has seven holes. Once you figure out how to make the pentagonal sticks and have the drilling jig adjusted correctly it is quite easy to make. I supplied them disassembled with instructions for assembly. About 20 made, 1987-1988. Photograph on next page.

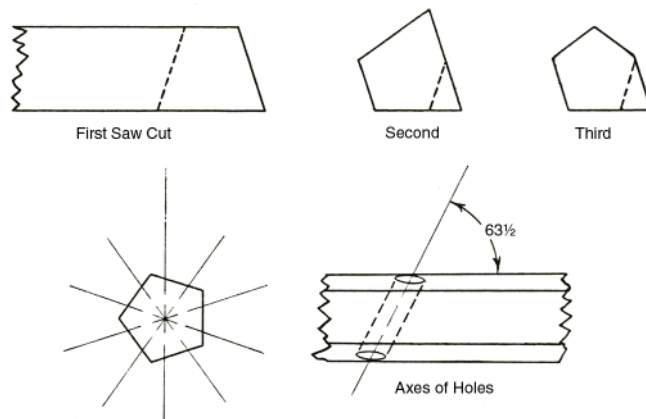

80-A No Name

This was a smaller version of **Thirty Pinned Pentagonal Sticks** (#80) with the sticks and dowels shortened and the two end holes omitted. One made in 1988.

80-B No Name

An even smaller three-hole version of **Thirty Pinned Pentagonal Sticks** (#80). One made in 1988.

81 Nest Construction Set

This name and number were assigned to the scheme of using pieces like those shown here joined together in more complicated assemblies, as was done with the **Locked Nest** (#22). A few experimental pieces were made but no practical sets were ever produced.

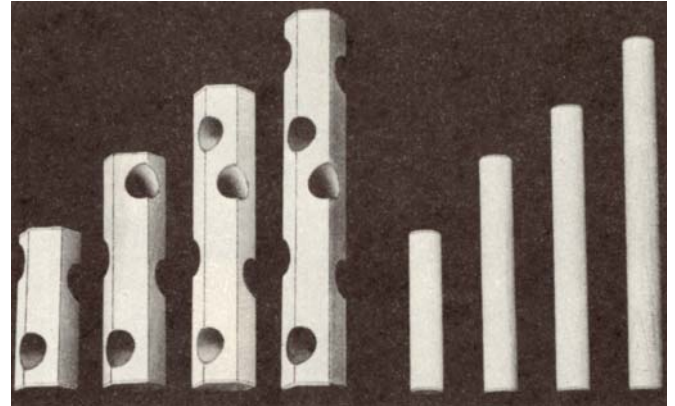

81-A Two-Three

As simple as it gets. Three sticks and three dowels go together one way, or two of the sticks and two dowels another way. A few made around 1988.



Two-Three (#81-A) in birch by Stewart Coffin



Thirty Pinned Pentagonal Sticks (#80) in mahogany & birch by Stewart Coffin

81-B-1 Four-Legged Stand

A simple little puzzle with four sticks and four dowels. Two of the dowels are fastened in holes, making one elbow piece and one cross piece. About 20 made, 1987-1988.



Four-Legged Stand (#81-B-1) in birch by Stewart Coffin

81-C-1 Double Four-Legged Stand

A much more complicated version of **Four-Legged Stand** (#81-B-1). The photograph tells all. Three made, 1987-1988.

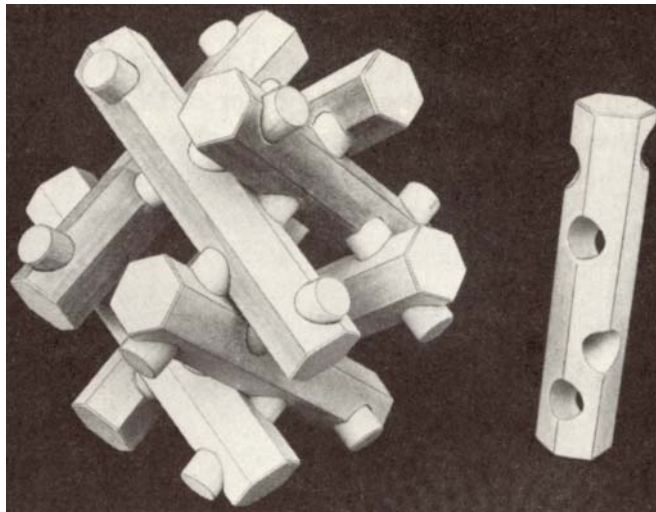

82 Patio Block

Eight pieces, each one made of $1 \times 2 \times 2$ rectangular blocks joined different ways, assembled to form a $4 \times 4 \times 4$ cube. The idea for this came to me in a publication by Ric van Grol, which attributes the original 10-piece design to Toshiaki Betsumiya and the 8-piece version to Kevin Holmes. Four made in 1988. Used in the IPP-22 puzzle exchange.

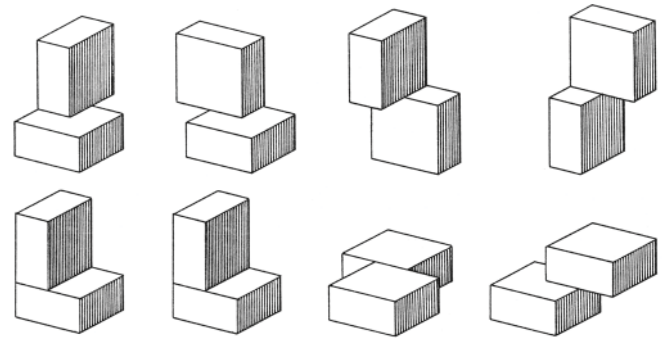

Patio Block (#82) in cocobolo by Stewart Coffin

83 Pentagonal Stand

Five identical pentagonal sticks are pinned together with five dowels.



Pentagonal Stand (#83) in oak & birch by Stewart Coffin

83-A Pentagonal Stand

A more popular version of **Pentagonal Stand** (#83) where two of the dowels are fixed in place to make elbow pieces. About 20 made in 1990.

84 Obstructed Pins

This could be considered a variation of **Locked Nest** (#22), with three holes in each of the 12 sticks rather than five, and no elbow pieces. Three of the sticks are slightly shorter at one end, allowing the first three dowels to be removed. Not a very elegant design. Two made in 1988.

84-A No Name

This was evidently a 30 pentagonal stick version of **Obstructed Pins** (#84). Details were never recorded. One made in 1988.

85 Twelve-Piece Separation

Twelve triangular sticks with pyramidal end blocks assemble with some difficulty to form a symmetrical interlocking burr. Consists of ten standard pieces, made from triangular stock crosscut at a 55 degrees, with rhombic pyramid blocks attached to each end, one augmented piece with one additional rhombic pyramid block from the key piece attached to the side, and the key piece (not shown in the drawing). Fully described in *Puzzle Craft 1992*, including construction details and solution. About 30 made, 1988-1992. A 1997 version in imbuaya and satinwood was 10% smaller, five made.

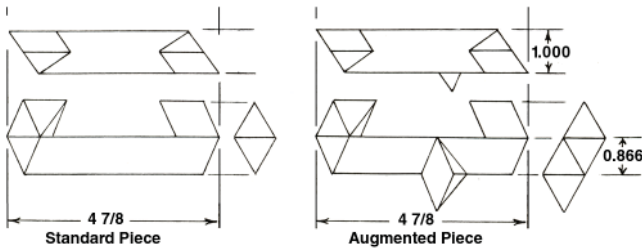

Twelve-Piece Separation (#85) in oily bocote, dense Cambodian rosewood, Brazilian kingwood & Macassar ebony by Lee Krasnow



Twelve-Piece Separation (#85) partially disassembled

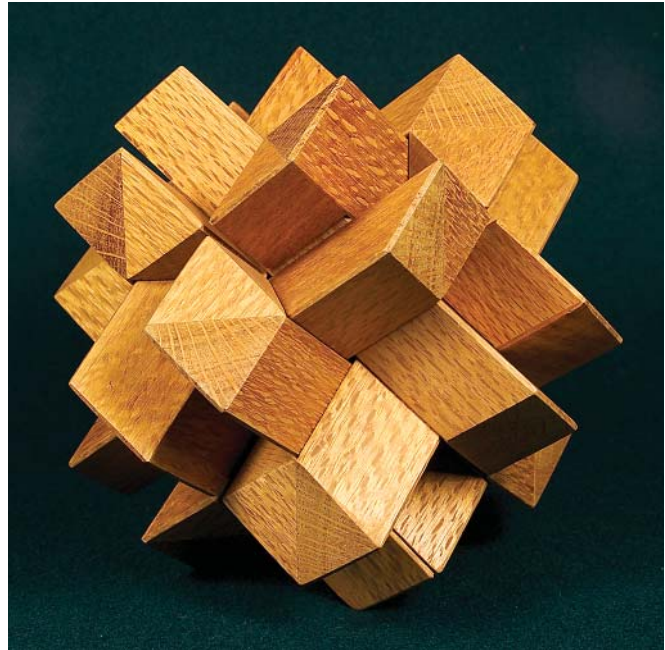

Twelve-Piece Separation (#85) in Lacewood by Stewart Coffin

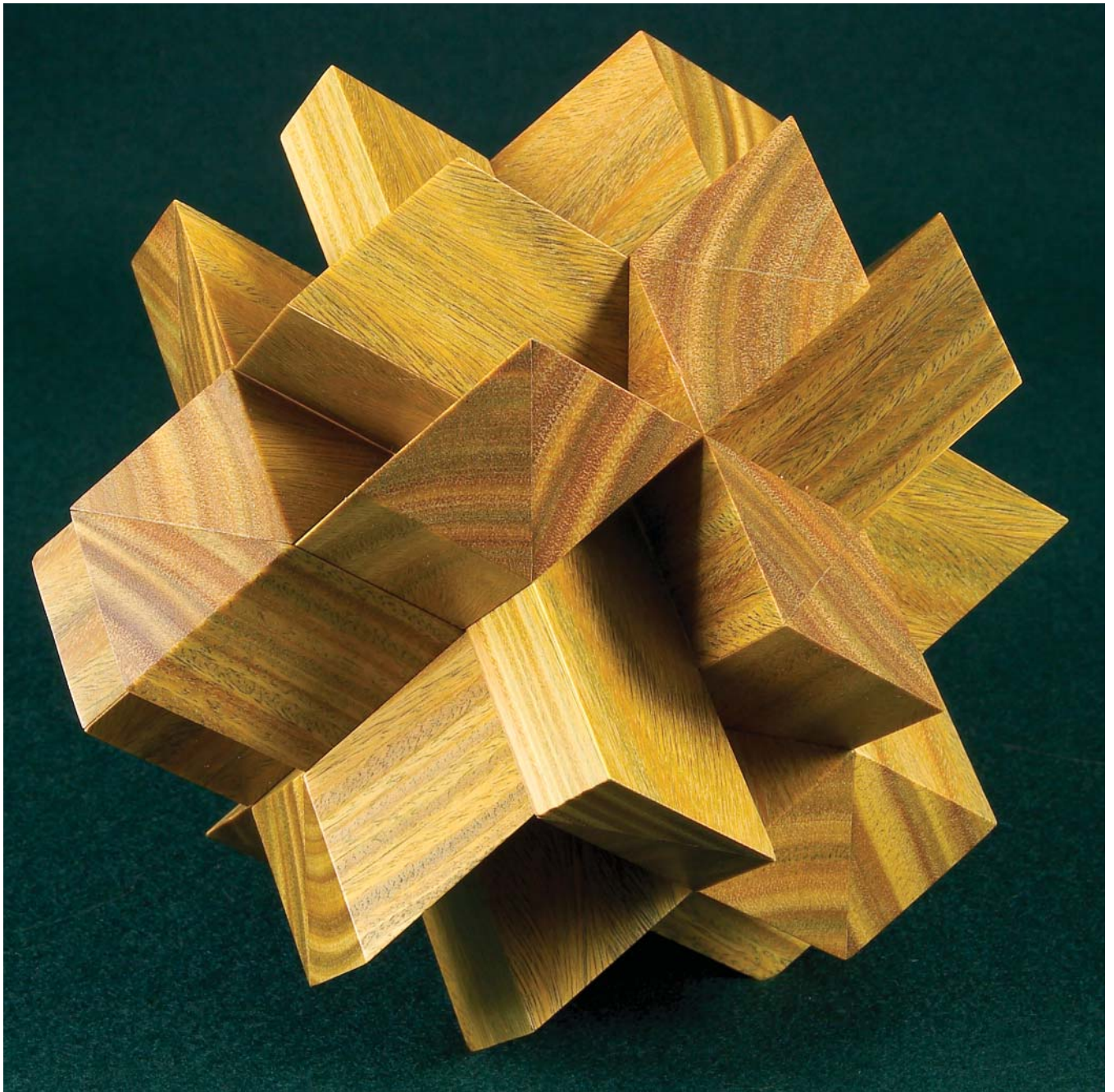

Twelve-Piece Separation (#85) in verawood by Lee Krasnow

85-A Geodynamics

This is a variation of **Twelve-Piece Separation** (#85) that has been distorted by expansion along one orthogonal axis and compressed along another—i.e. from cubic symmetry to that of a brick. To put it another way, all the sticks are of 50-60-70-degree cross-section. Very confusing to assemble, but the pieces are lettered in conjunction with the printed solution. Very difficult to make, requiring many complicated saw jigs, which took up so much space I finally threw them all away. Thirteen made in 1994. There was an even more complicated variation with additional blocks, but details not recorded. One made of Sitka spruce.



Geodynamics (#85-A) in mahogany by Stewart Coffin

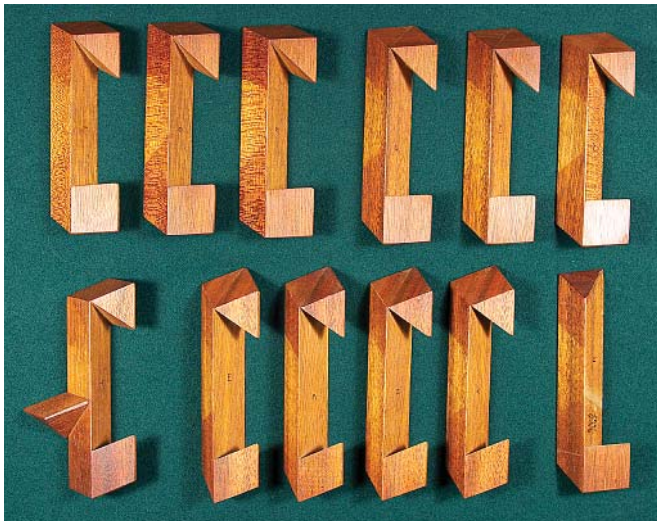

Geodynamics (#85-A) pieces

86 Four-Piece Separation

A derivative of **Twelve-Piece Separation** (#85). Four simple pieces, very easy to assemble. Just a novelty. See **Four-Piece Separation, Improved** (#190).

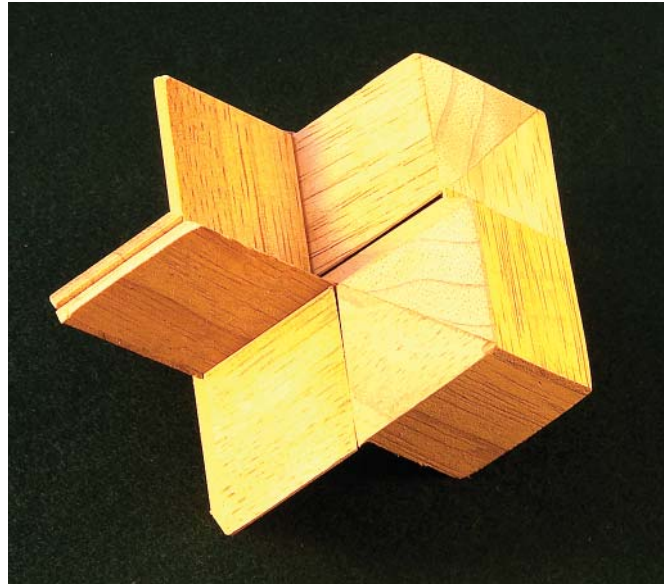

Four-Piece Separation (#86) in limba by Stewart Coffin

86-A Three-Piece Separation

Just a simple novelty, but it does involve coordinate motion. One made in 1988.

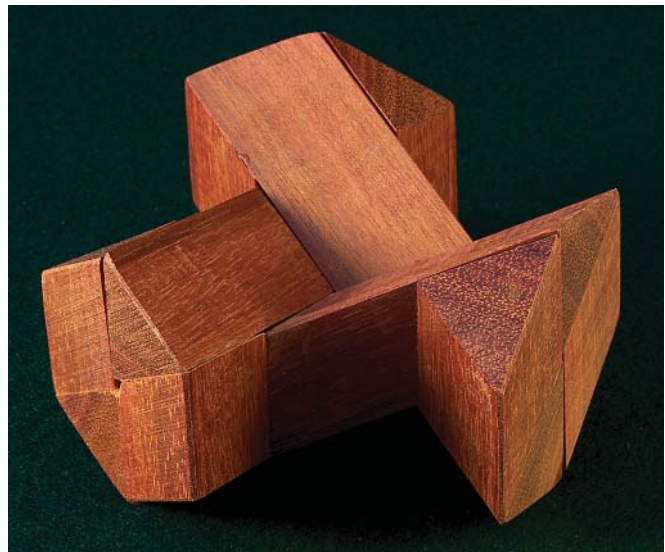

Three-Piece Separation (#86-A) in Honduras rosewood by Stewart Coffin

87 Two-Sided Tray

This was a six-piece diagonal dissection of the square. It came with a two-sided tray, square on one side and rectangular on the other. An oversized one was made for the Atlanta International Museum of ART and Design exhibit in 1993 and lost there. For improved version, see **Quadrilateral** (#87-A).

87-A Quadrilateral

This is an improved seven-piece variation of **Two-Sided Tray** (#87). It is more fully described in *Puzzle Craft 1992*. Designed in 1989 and produced for a while by Trench Enterprises in England.

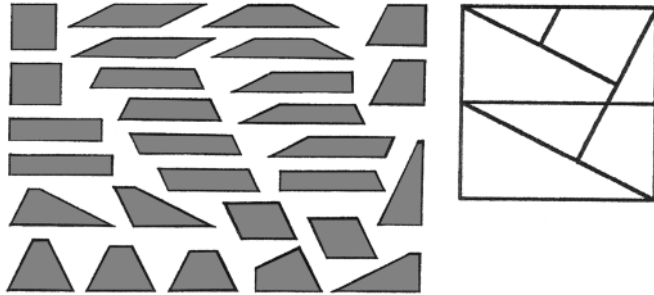

88 Little Rocket

Six bicolored pieces made up of tetrahedral blocks assemble to form a rhombic dodecahedron, held together in a square stand. Made from scraps left over from other projects. The shading shows how it can be made with two woods. There is only one solution. Ten made 1989-1990, a few more in 2003.

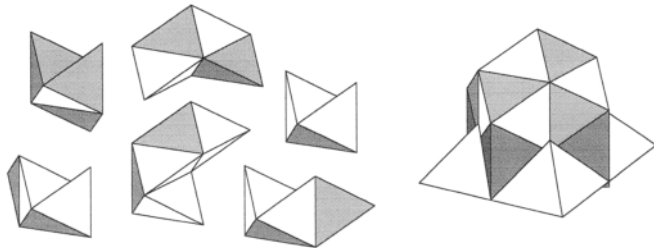

Little Rocket (#88) in camphorwood with tulipwood, cherry & lace-wood base by Stewart Coffin

89 Cylindrix

This was to be a variation of **Hexsticks** (#25-A) using round dowels rather than hexagonal sticks. One rough model was made long ago, which may still be around somewhere, but it did not work as well as hoped.

90 Permuted Four Corners

As the name suggests, this is a variation of the **Augmented Four Corners** (#34). Two were made and sold in 1990, but I failed to record the design details, which I now consider lost. All the more fun for someone to reinvent.

91 Pinned Triangular Sticks

Evidently this was to be a variation on **Hexsticks** (#25-A) in which twelve triangular sticks are held together with pins and holes rather than notches. Never got beyond some crude experimental models.

92 Queer Gear

Six pieces assemble to form a Star-of-David prism. A few made around 1985.

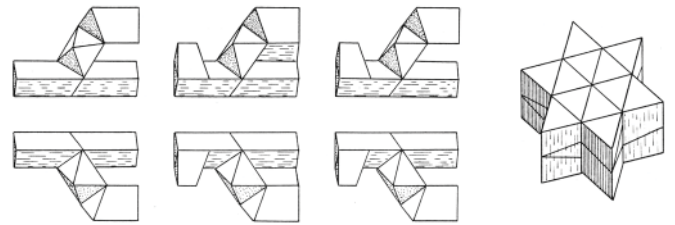

Queer Gear (#92) in koa by Mark McCallum

92-A Second Gear

This is a variation of **Queer Gear** (#92) in which the vertical axis has been compressed by 22%, changing all the angles and greatly complicating construction. Colorful wood combinations used to make eight in 1996.



Second Gear (#92-A) in mulberry, breadnut, walnut, satinwood, cherry & maple by Stewart Coffin



Second Gear (#92-A) halves separated

93 Four-Piece Serially Interlocking Cube

The name tells the story. A neat design. Three made in 1992, and three more in 2003.

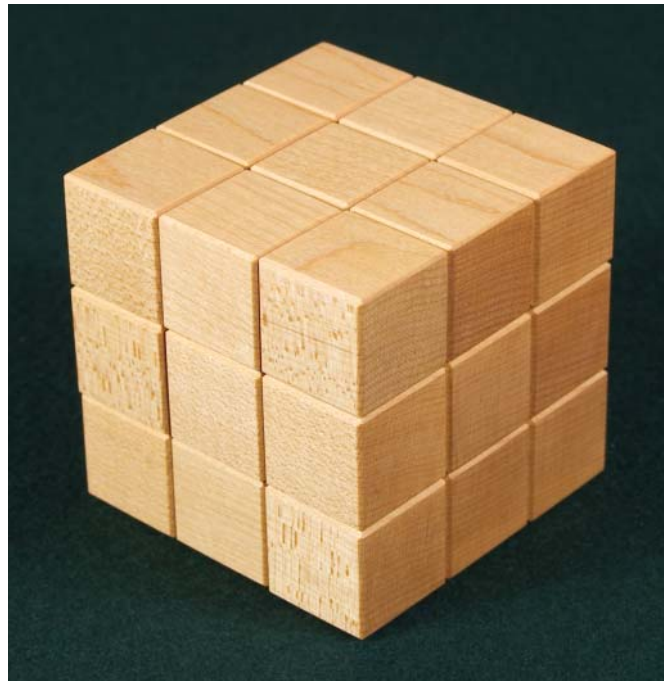
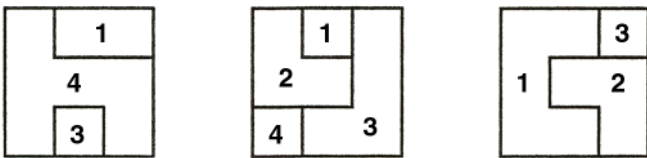

Four-Piece Serially Interlocking Cube (#93) in maple by Tom Lensch

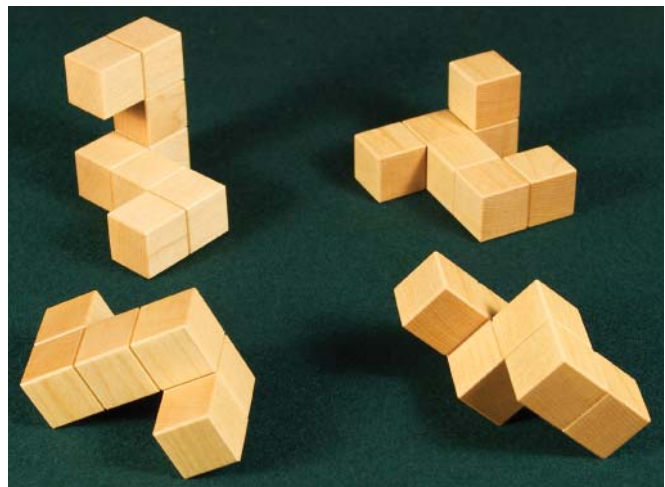

Four-Piece Serially Interlocking Cube (#93) pieces

94 Fourth Dimension

This is a derivative of **Pennydoodle** (#67-B). The four pieces, two of each kind, assemble with coordinate motion to make either a square or tetrahedral shape. Must be accurately made of stable woods to be satisfactory, and even then it is very hard to disassemble because of the inherent tendency to bind. Otherwise would have made more of this unusual novelty. Perhaps a slippery wood like teak would help. Made four in 1991.

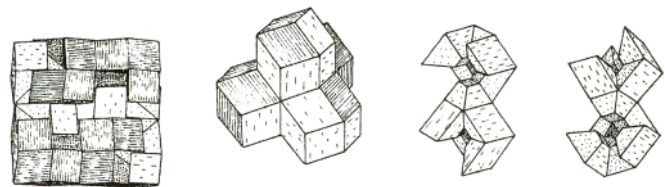

95 All Star

This is an extension of **Star-of-David** (#37). The six dissimilar pieces assemble many mysterious ways to make intriguing

shapes, all of which are explained on its accompanying instruction sheet. About ten made in fancy woods starting in 1990. The design of the pieces is here published for the first time. Two dissimilar woods are used, light and dark.

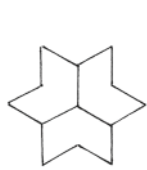
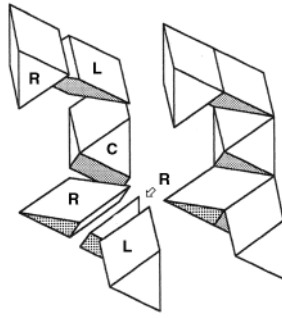
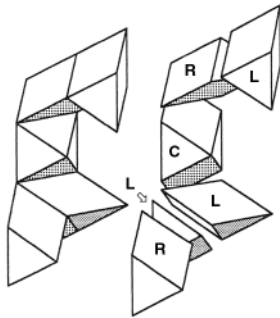
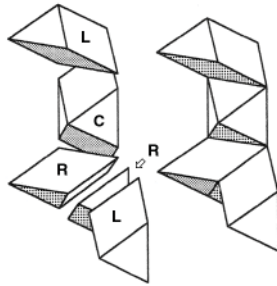
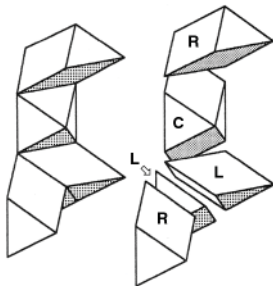
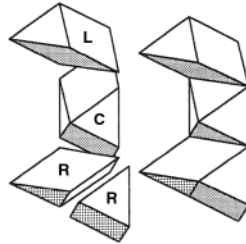
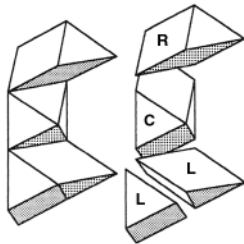
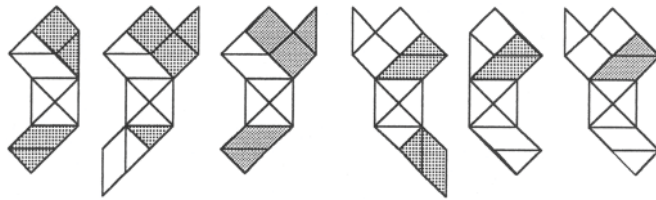

Star-shaped column with stellated ends
2 diagonal solutions

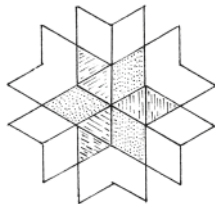

Oblate solid with six- and twelve-pointed star patterns
2 axial solutions

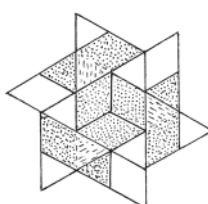

A bizarre solid with triangular patterns and twelve points
2 diagonal solutions and 2 axial solutions

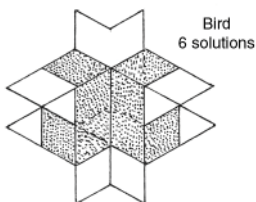

Bird
6 solutions

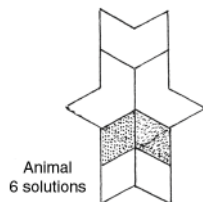

Animal
6 solutions



All Star (#95) by in padauk & cherry Stewart Coffin

96 Teddy Burr

This six-piece burr is derived from one of the simplest types, with one piece having an extra notch that allows the key piece to slide out. What makes it different is that all the sticks are skewed by 5 degrees to rhombic rather than square cross-section, which makes all the difference. Eight made in 1993.

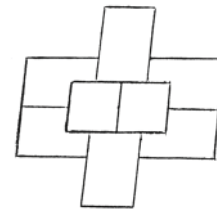

Teddy Burr (#96) in oak by Stewart Coffin

96-A Grizzly Burr

In this version, the sticks are all square but they are rotated in pairs by five degrees along their axis away from the usual orthogonal arrangement, making the solution surprisingly confusing. A neat puzzle and easy to make using a standard dado cutter. About 30 made in 1994. Angles are exaggerated for illustration.

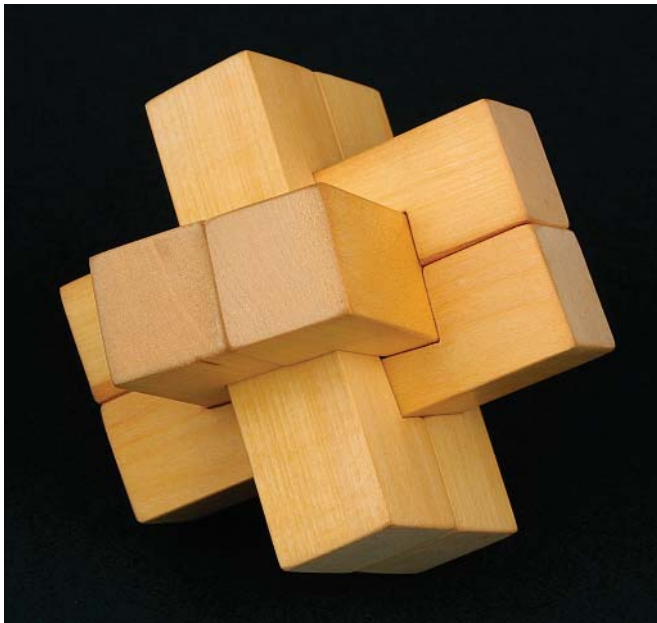
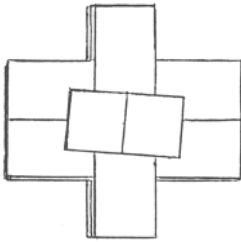

Grizzly Burr (#96-A) in basswood by Stewart Coffin

96-B Double Notch

Superficially similar to **Grizzly Burr** (#96-A), but the double notch feature interjects confusing extra moves to assemble. Used in the IPP-16 puzzle exchange.

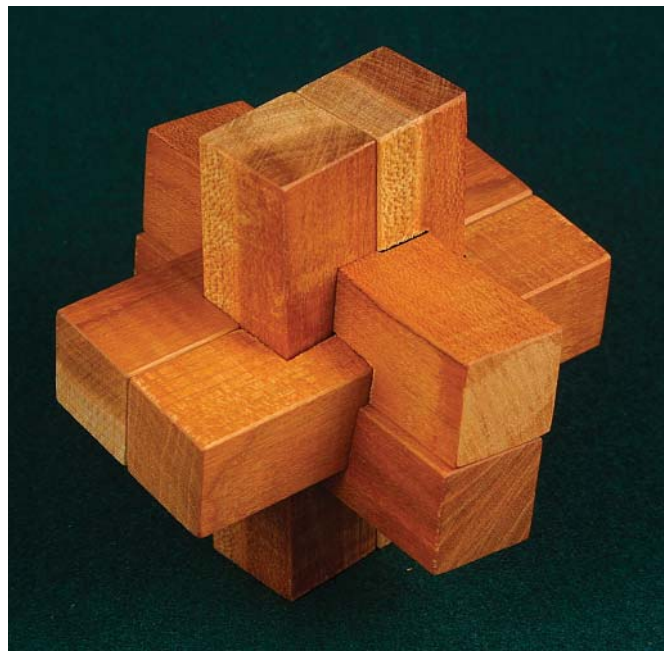

Double Notch (#96-B) in cherry by Stewart Coffin

97 Crooked Notches

This design is derived from the familiar six-piece diagonal burr, which is here compressed along one of its three-fold axes, making the sticks rectangular rather than square and the notches crooked. Used in the IPP-14 puzzle exchange.

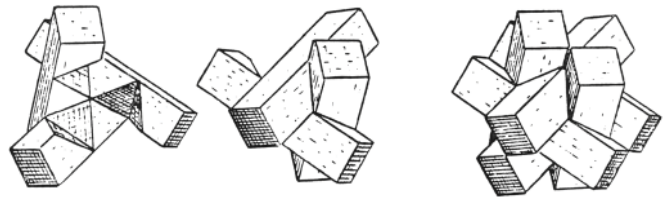

Crooked Notches (#97) in pine by Stewart Coffin

98 Yogi Burr

More complicated and confusing than **Teddy Burr** (#96), **Grizzly Burr** (#96-A), or **Double Notch** (#96-B) because of the bizarre combination of slant and skew. Also more difficult to make. Several made in 1994.

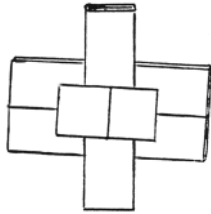

Yogi Burr (#98) by Stewart Coffin

98-A Slant Six

This version combines all of the diabolical complications of the preceding versions. About 30 of a deluxe edition were made in 1994 of choice padauk.

The six dissimilar pieces for the **Slant Six** are shown below. All of the angles have been greatly exaggerated here for purpose of illustration. The actual deviation from right angles is only 5 degrees. I used $\frac{3}{4}$ -inch square padauk, a wood selected for its workability, attractiveness, and excellent stability.

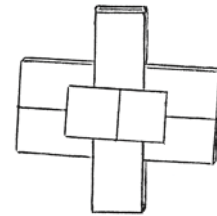
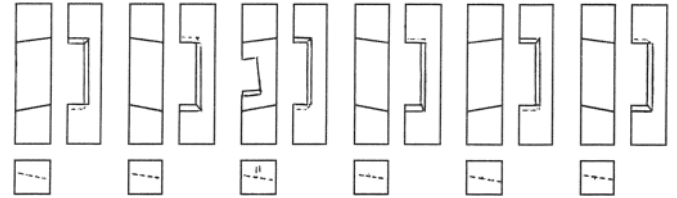

Slant Six (#98-A) in padauk by Stewart Coffin

99 Disinclination

This can be visualized as a **Seven Woods** (#42) that has been distorted by compression along one of its threefold axes, making the faces rectangular rather than square and changing all the angles, same as **Crooked Notches** (#97). A few were made in 1994.

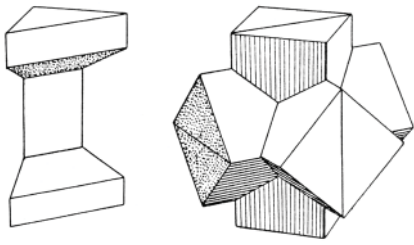

Disinclination (#99) in padauk by Stewart Coffin

100 Concentrix

This is a variation of **Hectix** (#25), made by machining down the ends of the styrene pieces to achieve an entirely different geometrical shape, which I have described as two concentric first stellations of the rhombic dodecahedron, but now I'm not so sure. Whatever, only the one model made, which is now in the Slocum collection, but it led in turn to the **Meteor** (#100-A).

The drawing is as best I can remember. I am guessing that extra notches, not shown, allowed insertion of the key piece as in the original **Hectix** from which it was derived.

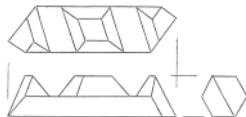

100-A Meteor

Although you might not guess from casual inspection, this is a derivative of **Hectix** (#25). Twelve pieces form an interlocking burr. Designed in 1993, I have made only one rough model in pine. It has always been my intention to set up jigs and produce a batch of these in fancy wood, but it doesn't seem to be happening. Accordingly with the basic tools, including the triangular block jig described in *Puzzle Craft 1992*, it should not be difficult to make.

The drawing represents my attempt to show one of the **Meteor** pieces. It is not as complicated as it looks. The base is a flat trapezoid to which are attached a truncated pyramidal center block and two tetrahedral end blocks with beveled edges. For more information, see *Puzzle Craft 1992*. Three pieces have the center block missing. The key piece has the center block and one end block missing. One of the eight remaining pieces is augmented with the missing end block.

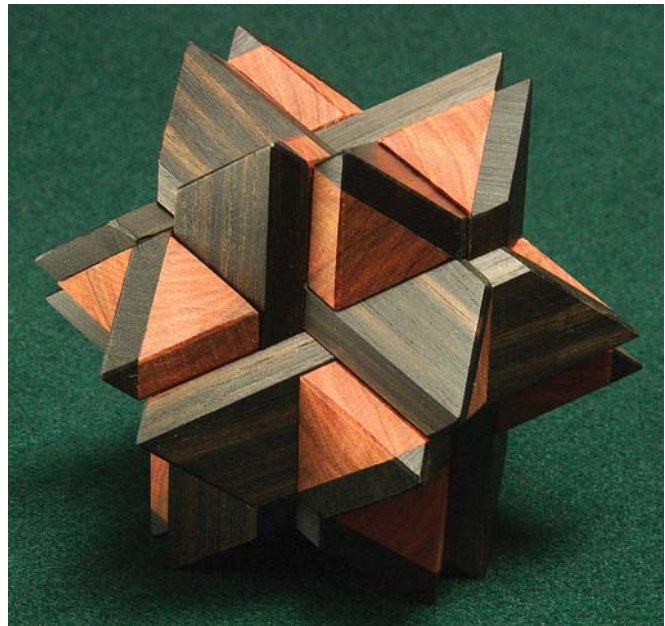
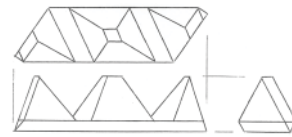

Meteor (#100-A) in ebony & redheart by Bart Buie



Meteor (#100-A) in holly, zebrawood, yellowheart, redheart & Honduras rosewood by Bart Buie

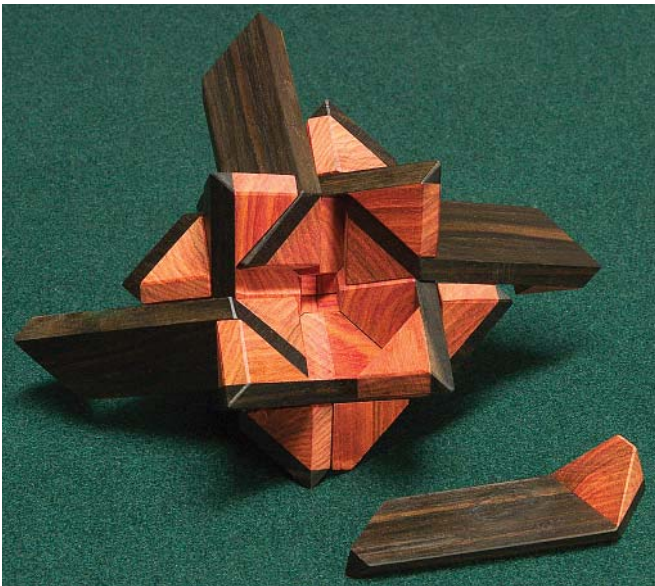

Meteor (#100-A) partially disassembled to the point where the three extended pieces easily slide out

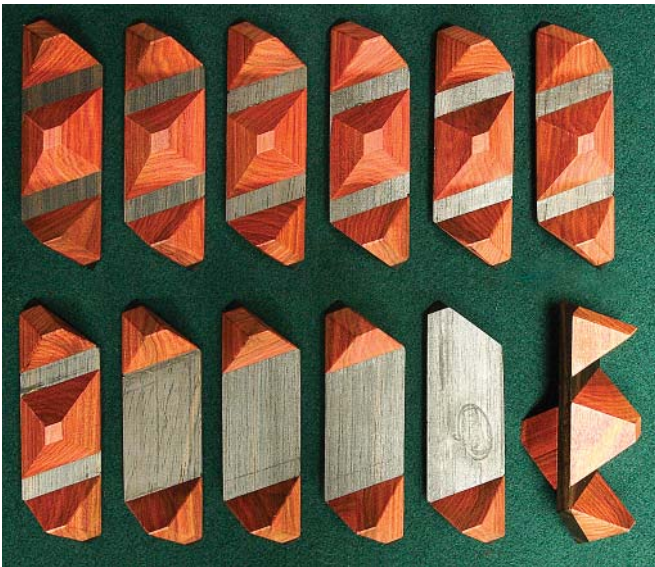

Meteor (#100-A) pieces

101 Isosceles

This is a 12-piece burr made with triangular sticks with triangular stick segments attached to the ends. All of the end faces are cut off squarely, i.e. perpendicular to the axes. It is distorted by compression along one of its fourfold axes, thus making all of the sticks having 50-65-65-degree cross-section rather than equilateral. Or to put it the other way, changing the cross-section produces the distortion. Three of the pieces, all mutually parallel, are the key pieces and go in last. They have blocks on one end only, and these missing blocks, marked A in the illustration, are attached instead to three other pieces to make augmented pieces. All of the required saw cuts are at odd angles requiring trigonometry to calculate and special jigs to saw. In other words, this is a project only for a woodcrafter with considerable skill and determination. A few were made in 1994.

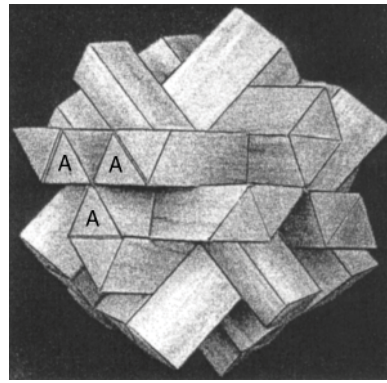

Isosceles (#101) in camphorwood by Stewart Coffin

101-A Iso-Prism

This is simply an **Isosceles** (#101) in which the empty spaces have been filled in with 24 more blocks, making the eight faces triangular and all 12 pieces dissimilar. This makes the already difficult puzzle even more difficult. The way that the blocks are attached is indicated in the drawing, with the key pieces marked K. A few were made in 1994.

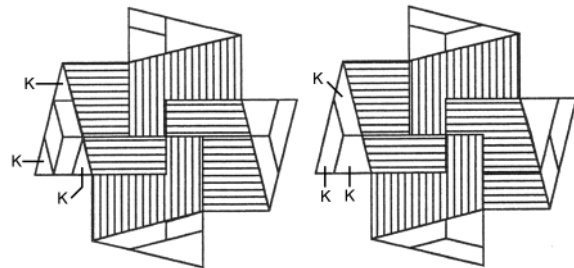



Iso-Prism (#101-A) in camphorwood by Stewart Coffin

102 Incongruous

This is an unusual variation of the familiar six-piece diagonal burr in which the sticks have rhombic cross-section and require coordinate motion to assemble. One piece has an extra notch. Used in the IPP-15 puzzle exchange. The drawing shows the piece with extra notch. The angle of the rhombic cross-section is critical and is calculated by vector analysis to be 76.9 degrees.

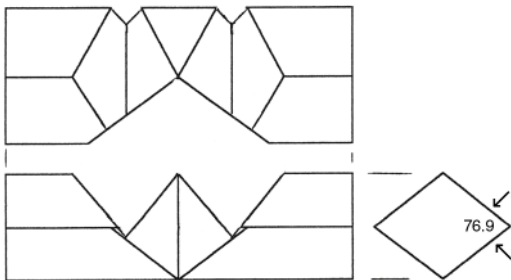

Incongruous (#102) in Cherry by Stewart Coffin

102-A Redemption

This puzzle has exactly the same shape as **Incongruous** (#102) when assembled, with the same rhombic cross-section. The difference is internal. There are two pieces with an extra notch rather than one, and the notches are different. This time it is the relation between the angles that is critical. For the rhombic angles used, the angle of the notch is 19 degrees, as indicated. This puzzle is even more frustrating to assemble. Two were made of walnut in 1995. The drawing shows a comparison of notch angles between #102 and #102-A.

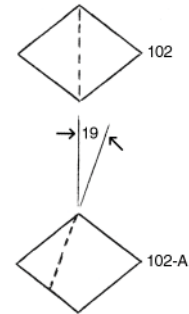

103 Missing Piece!

When disassembled this puzzle has a superficial resemblance to the **Cuckoo Nest** (#21), but with only five bars instead of six, hence the name. In this version, three of the dowels are fixed in place to make two elbow pieces and one cross piece. The bars are 3/4-inch diameter and the dowels 3/8-inch. The holes are all drilled at an angle of 78 degrees to the axis, and their spacing is best determined by trial and error. Used in the IPP-16 puzzle exchange.



Missing Piece (#103) by in birch by Stewart Coffin

104 Tech Sticks

This is a farcical variation of **Hexsticks** (#25-A) in which the assembled burr has been distorted by compression along one four-fold axis and expanded along another, giving it more or less the symmetry of a brick, like **Twelve-Piece Separation** (#85-A). Its creation was mostly an exercise in trigonometry and jig making, requiring several days and numerous special jigs, all of which I later discarded because they occupied so much space. There are three key pieces with split ends, and the last step of the surprising and baffling assembly is the mating of two halves. Seven were made of mahogany in 1995.

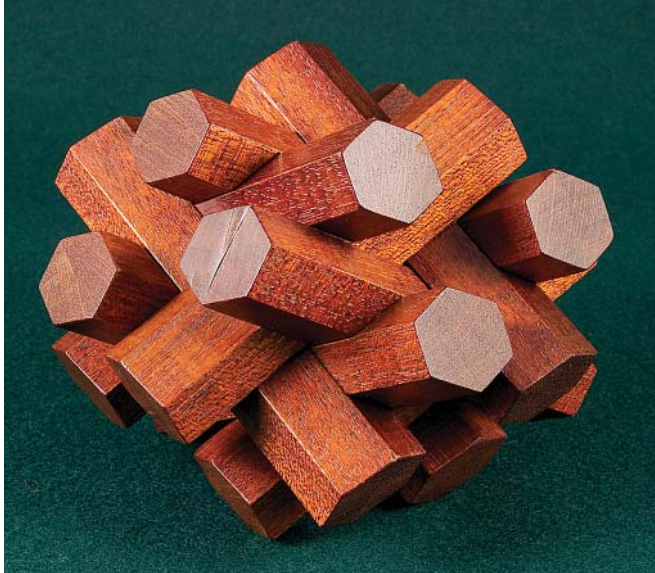

Tech Sticks (#104) in mahogany by Stewart Coffin

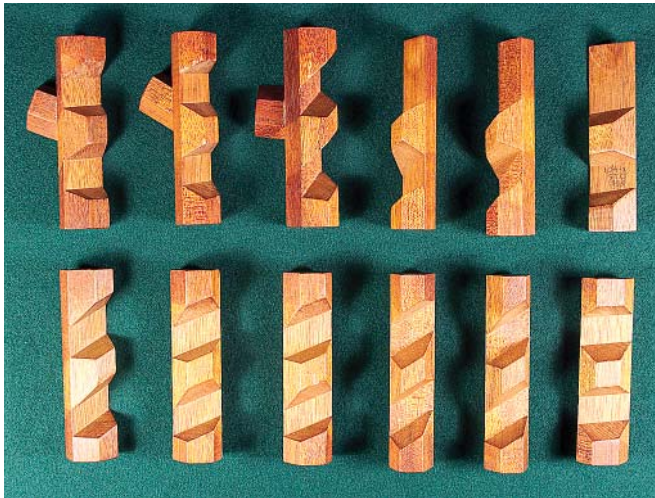

Tech Sticks (#104) pieces

104-A Tech Sticks in Four Woods

You might think that the use of contrasting woods might give hints on the assembly, but in this case I wouldn't be so sure, as they are not arranged in the obvious way. Two made in 1995.



Tech Sticks (#104-A) in oak, satinwood & purpleheart by Stewart Coffin

105 Lock Nut

An unusual variation of the six-piece diagonal burr. The pieces are $\frac{1}{2} \times 1 \times 3$ inches. The $\frac{1}{2}$ -inch wide notches are easily cut with a standard dado. There is nothing unusual about the angles either, same as the regular diagonal burr. There are two kinds of pieces, three of each. They assemble with coordinate motion. Used in the IPP-16 puzzle exchange, made in Honduras rosewood.



Lock Nut (#105) in Honduras rosewood by Stewart Coffin

106 Burr Noodle

This puzzle has the superficial appearance of an ordinary six-piece diagonal burr, but don't be fooled. It is anything but. There are two kinds of pieces, three of each, and the final step of assembly is the mating of mirror-image halves. The pieces are of rhomboid cross-section, 0.800×0.780 , 3 inches long, and 85 degrees acute angle. The notches are cut as shown, and must be cut very accurately of stable wood. Used in the IPP-17 puzzle exchange, made of especially dense padauk. Incidentally, it is often a characteristic of this wood to exude a white powder that becomes deposited on the surface. Many persons have mistaken this for mold, which it is not. Just wipe it off occasionally. This applies to all puzzles made of this bright red wood.

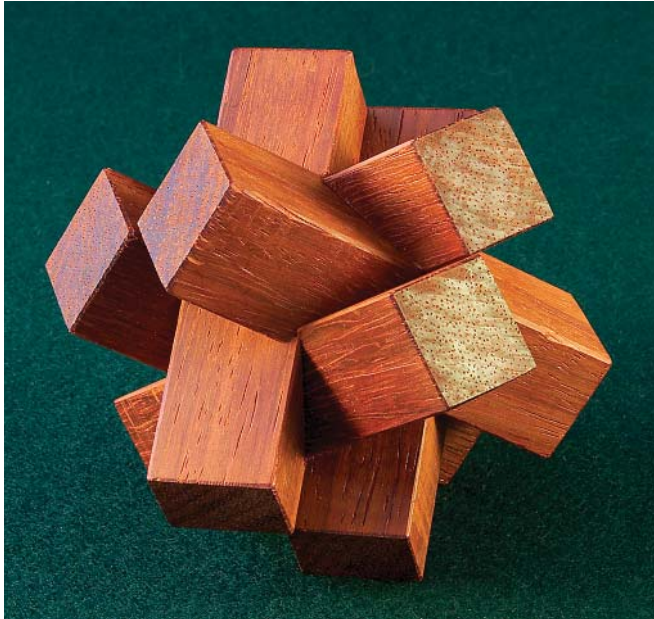
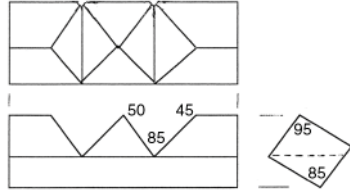

Burr Noodle (#106) in padauk by Stewart Coffin

106-A Reluctance

This was to be a more non-symmetrical version of **Burr Noodle** (#106). The idea was to make it more confusing, but this proved to be unnecessary! Consequently it never got beyond the one experimental model.

107 Trillium

This is so similar in principle to the **Disinclination** (#99) that I don't know why I assigned a new name and number. It is made from 0.816×0.695 rectangular stock. The angles of the notches are 55 and 35 degrees, making the amount of compression 15%. Used in the IPP-16 puzzle exchange, made in oak.



Trillium (#107) in oak by Stewart Coffin

107-A Augatron

This is an augmented version of **Trillium** (#107), made by adding six more end blocks in a way such that all six pieces are dissimilar. This produces a more interesting puzzle that is also harder to disassemble. Four made in 1995.

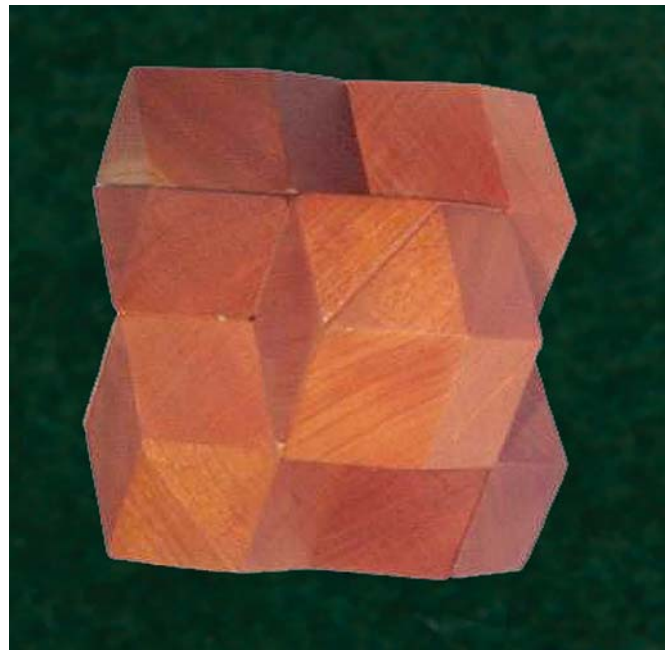

Augatron (#107-A) in mahogany by Stewart Coffin

108 Nonesuch

A distorted version of **Four Corners** (#6), made by vertical compression, i.e. along a three-fold axis. Two rough models made in 1995 for possible use as an exchange puzzle, but never used. Not a very inspired design.

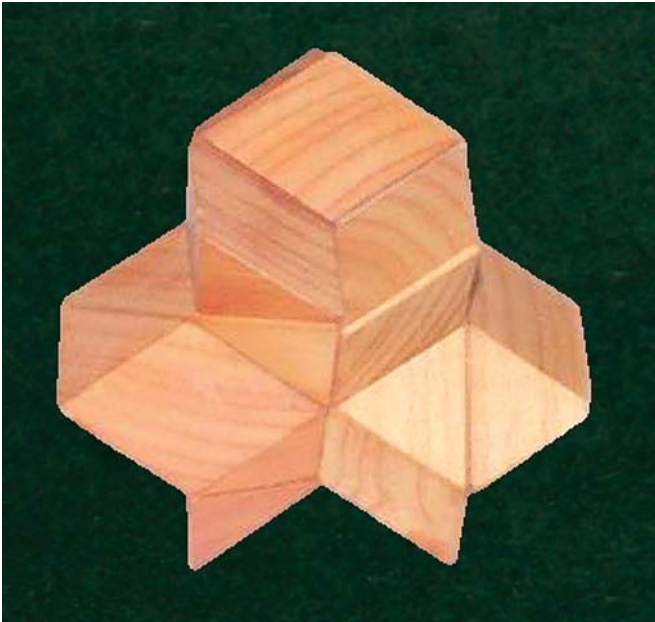

Nonesuch (#108) in maple by Stewart Coffin

109 Slokum-Pokum

This is a derivative of the **Pin-Hole** (#20) made of 85 degree rhombic sticks with dimensions $\frac{3}{4} \times \frac{3}{4} \times 2\frac{3}{8}$ inches. Another difference is that one end of the key pin is a dummy, so that pin does not poke out as expected but must be pulled out. Used in the IPP-16 puzzle exchange, made in mahogany.

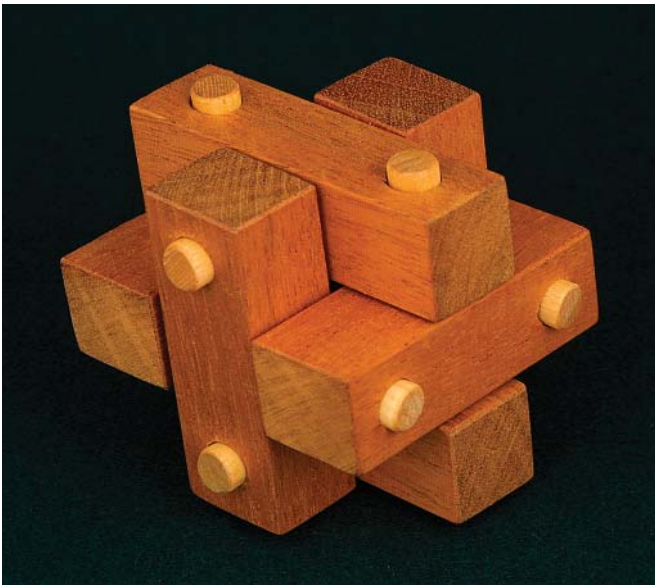

Slokum-Pokum (#109) in mahogany & birch by Stewart Coffin

109-A Foul Dowel

This is a version of **Slokum-Pokum** (#109) made instead with $\frac{3}{4}$ -inch round dowels, even more confusing than the original. There are two cross pieces and three elbow pieces, all dissimilar,

with same 85 degree angles. Unfortunately only the one experimental model was made in 1995, Not very difficult to make, and a good project for some aspiring puzzle maker.

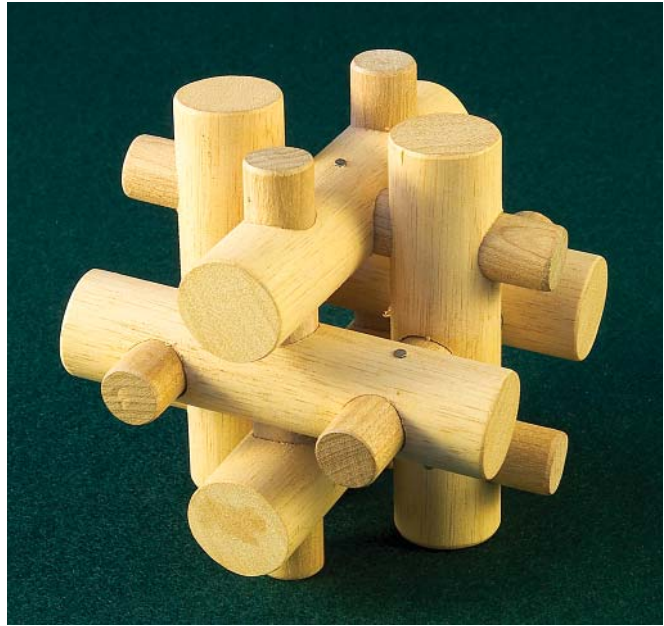

Foul-Dowel (#109-A) in Birch by Stewart Coffin

110 Octo Burr

This unusual eight-piece burr is made from $\frac{3}{4}$ -inch square sticks $3\frac{1}{4}$ inches long, with crooked notches. To cut the notches the sticks are rotated 30 degrees about their axis, turned at a miter angle of 60 degrees, and the table tilted to 54.7 degrees. Sounds complicated? It was! Six of the sticks are joined in pairs to make three dissimilar compound pieces. On the instruction sheet for this puzzle it is named **Spare Pair**. Used in the IPP-17 puzzle exchange, made in maple.

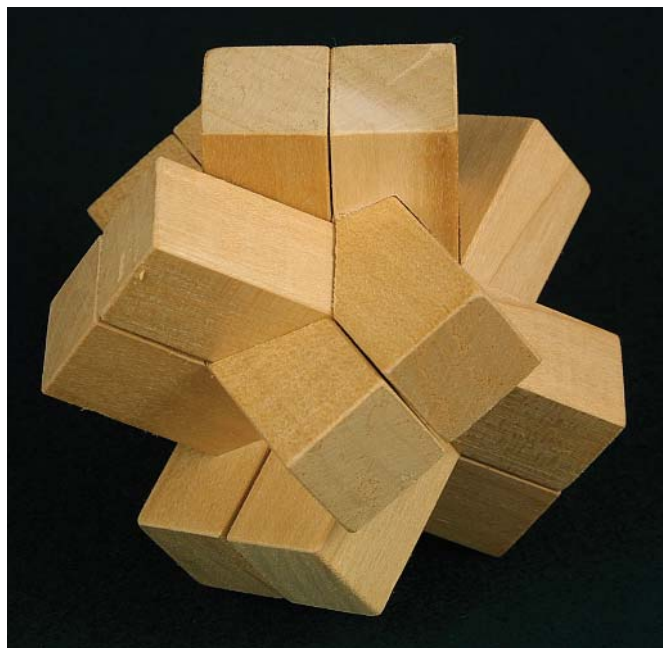

Octo Burr (#110) in maple by Stewart Coffin

111 Lost and Found

Six identical pieces go together by mating two dissimilar halves, and each half involves coordinate motion of all three pieces—unusual. My original model, dated 1973, was put away and forgotten until recently rediscovered, hence the name. Fairly easy to make with the right jigs. Five made of mahogany in 1995.

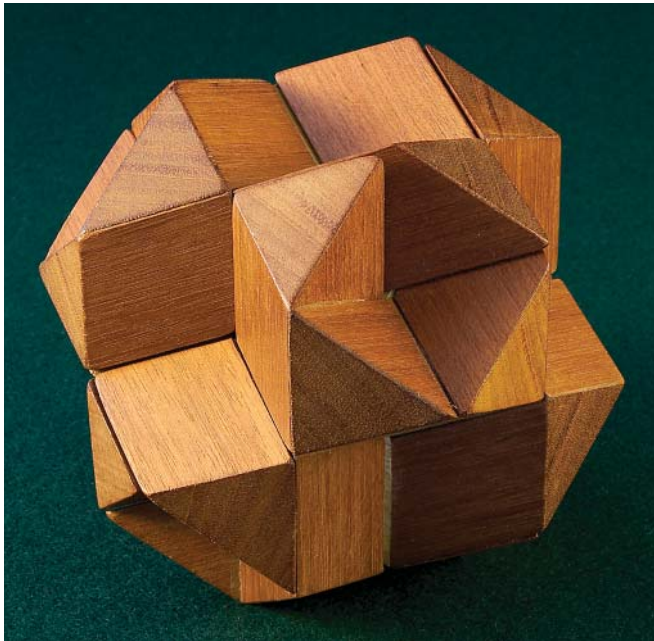
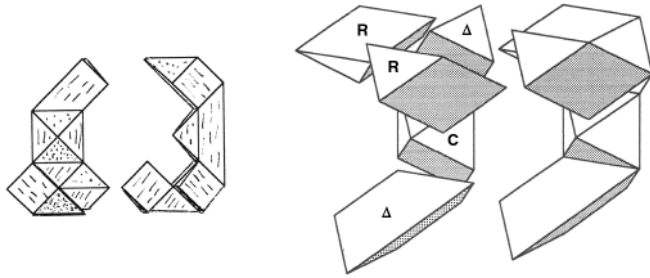

Lost and Found (#111) in mahogany by Stewart Coffin

111-A Lucky Star

This is functionally the same as **Lost and Found** (#111) but the extra length of both arms gives it the shape of **Vega** (#46). Especially nice when made of two contrasting woods. Six made in 1995 of mahogany and satinwood.

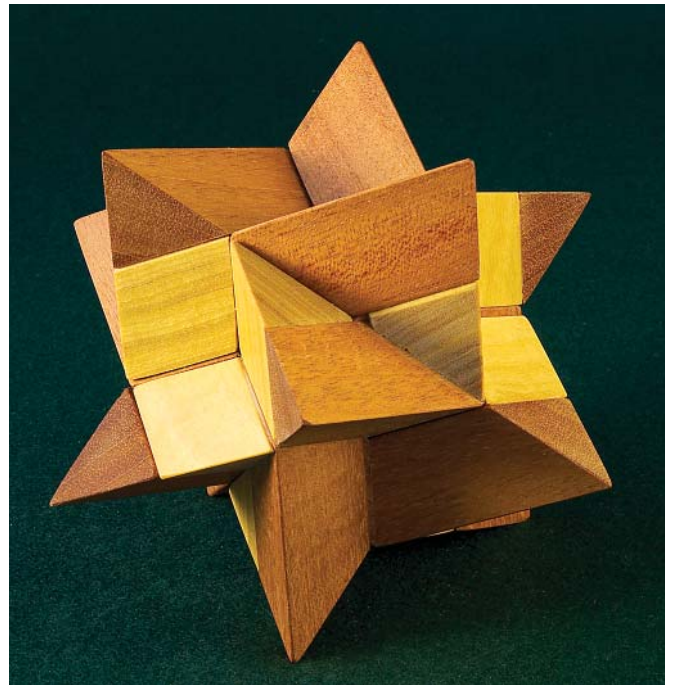
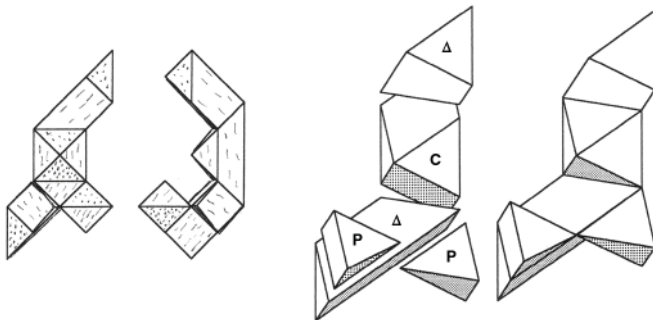

Lucky Star (#111-A) in mahogany & satinwood by Stewart Coffin

111-B Star Dust

This one is likewise functionally the same as **Lost and Found** (#111), but another addition gives it the shape of the third stellation of the rhombic dodecahedron. Two made of mahogany in 1995.

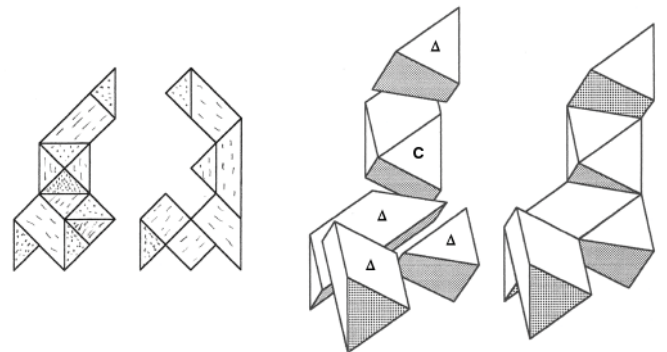

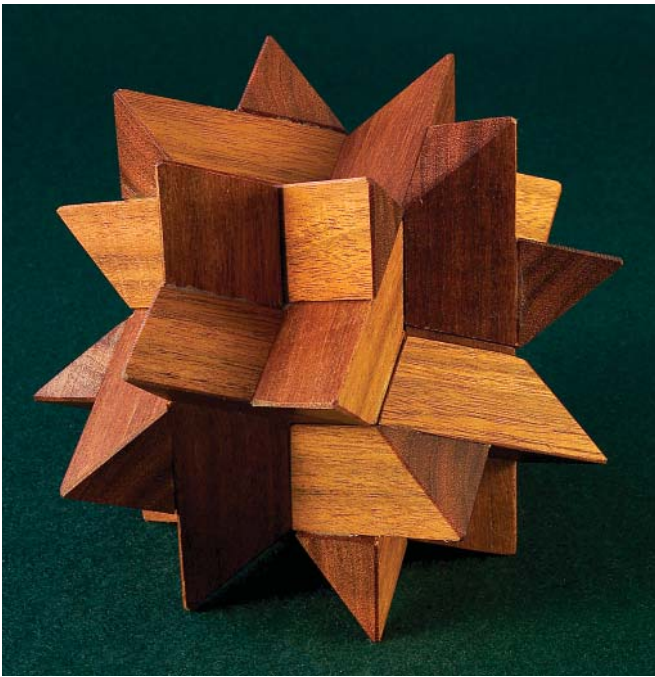

Star Dust (#111-B) in mahogany by Stewart Coffin

111-C A-B-C

Has the superficial appearance of **Star Dust** (#111-B), but has three kinds of pieces, two of each. The name is intended to mislead. It goes together in two halves, and anyone familiar with other AP-ART designs would surely expect each half to be A-B-C. Four made, 1995-1997.

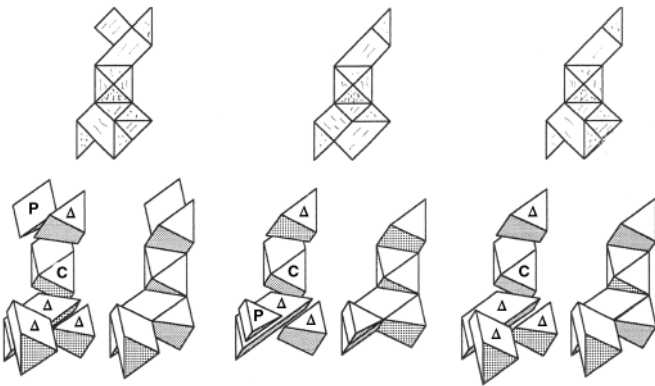

111-D No Name

Another family member. Two kinds of pieces, three of each. Goes together in two halves, both of which require coordinate motion. More confusing than any of the others to disassemble. Easy to make, because all attached blocks are common AP-ART prism blocks. For more information, see *Puzzle Craft 1992*. Especially nice in contrasting woods. One made in 1995 of teak, satinwood, and padauk.

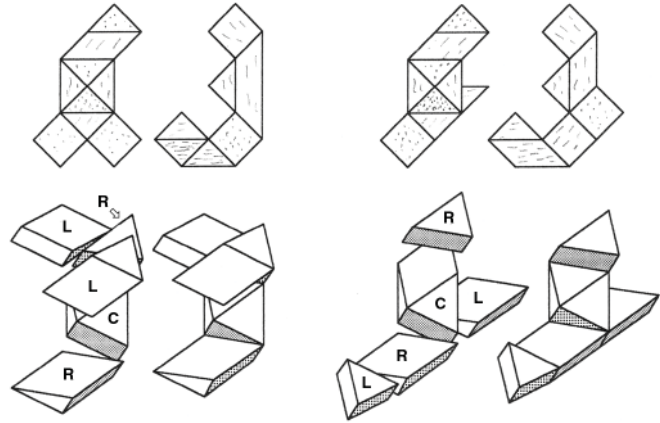

112 Burr Muda

Has same shape as **Triangular Prism** (#12), but six identical pieces require coordinate motion and dexterity to assemble. Ten made of maple in 1995.



Burr Muda (#112) in maple by Stewart Coffin

113 Sliparoo

Similar to **Burr Muda** (#112) except that the square ends of the six identical pieces give a different appearance and make it perhaps even more frustrating to assemble. Used in the IPP-17 puzzle exchange, made in mahogany and maple.



Sliparoo (#113) in mahogany and maple by Stewart Coffin

114 Cluster Plus

This has a superficial resemblance to **Cluster-Buster** (#49), but that is where the similarity ends. It is difficult to disassemble and very difficult to assemble. The six dissimilar non-symmetrical pieces fit together in two halves of three pieces each, and each half involves awkward coordinate motion with rotation, requiring patience and dexterity. Eleven made of cherry in 1996, five of which were given out as tokens at IPP-17. Note that if accurately made the puzzle is impossible to assemble unless the center blocks are slightly rounded or truncated.

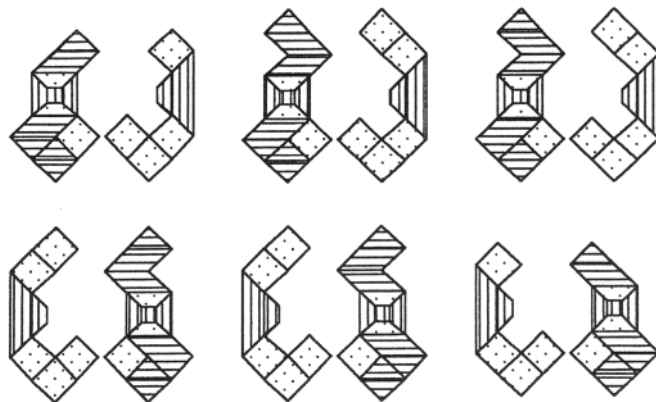

Cluster Plus (#114) in cherry by Stewart Coffin

115 Fancy This!

A serially interlocking burr made up of seven dissimilar non-symmetrical pieces. In this version, four contrasting woods are used, with all like woods being mutually parallel. This aids in the otherwise very difficult solution, the first step of which involves tricky coordinate motion. Note similarity to **Seven-Piece Third Stellation** (#73). One of my favorite AP-ART designs, and not too difficult to make. Eight made in 1996.

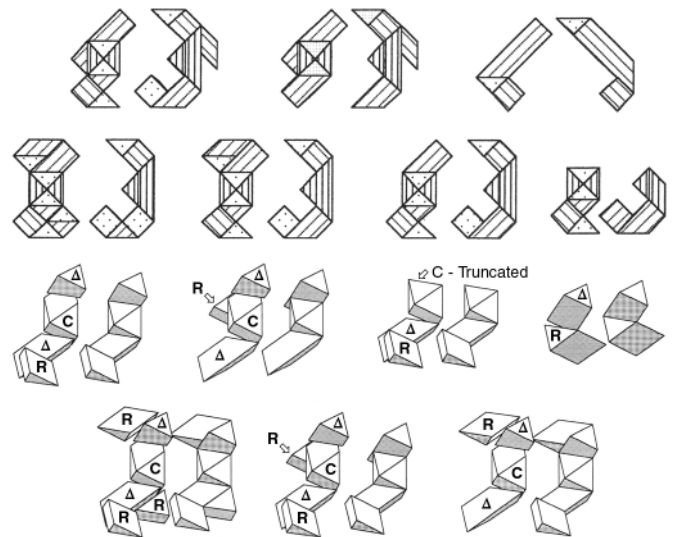

115-A Fancy This!

A more difficult reproduction of this puzzle, shown in the photograph, was beautifully crafted all in one wood by Wayne Daniel and used in the IPP-17 puzzle exchange.

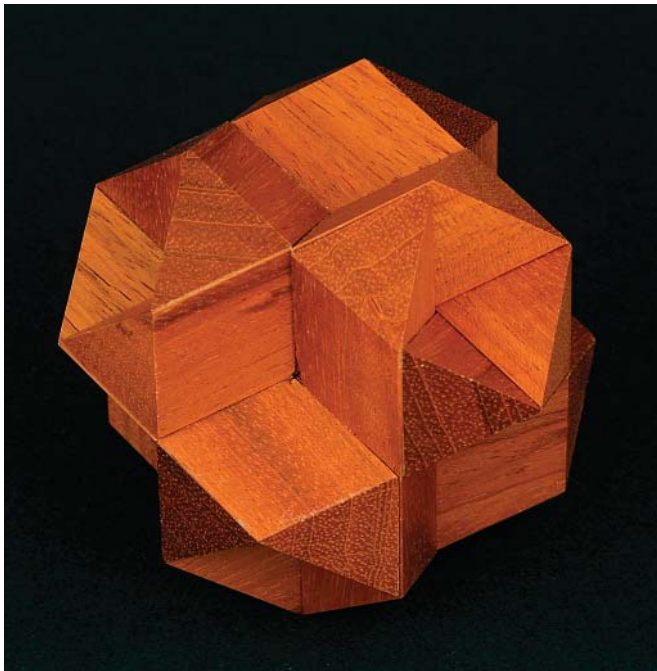

Fancy This! (#115-A) in mahogany by Wayne Daniel

116 Burr Circus

Evidently this was to be a six-piece diagonal burr made with square sticks skewed. My first edition of AP-ART notes that six were made in 1995, but now I wonder, since I have none, I have no record of having sold any, and no design notes.

117 Overdrive

Third and last of the “Gear” family. Involves coordinate motion of all six pieces to assemble, a maneuver so tricky that I also designed an assembly jig for it. There are two kinds of pieces, three of each, mirror images of each other. Five made in 1996 of teak, chosen because it is slippery.

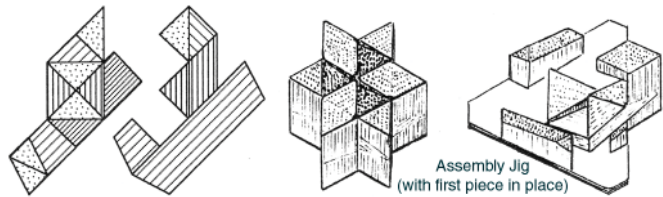

118 Three Bunnies

Three dissimilar non-symmetrical pieces assemble with coordinate motion to form a triangular cluster of three rhombic dodecahedra. With a little imagination the pieces resemble bunnies, hence the name. Used in the IPP-18 puzzle exchange, made in cherry.



Three Bunnies (#118) in cherry by Stewart Coffin



Three Bunnies (#118) pieces

119 Cluster's Last Stand

The last in the Cluster family and by far the best. See **Cluster-Buster** (#47), **Truncated Cluster-Buster** (#48), **Improved Cluster-Buster** (#49) and **Cluster Plus** (#114). This puzzle has baffled experts. Six dissimilar non-symmetrical pieces assemble with coordinate motion to form an octahedral cluster of six rhombic dodecahedra. Three of the pieces are shown and the other three are their mirror image. The critical angle shown in the end views must be $\arctan 1/3$, or 18.4 degrees. About 18 were made, 1996-1997. They were in cherry and imbuva, as suggested by the shading in the drawings.

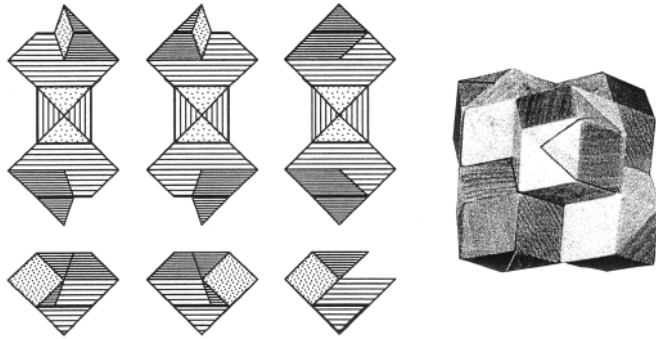

Cluster's Last Stand (#119) in teak & bloodwood by Stewart Coffin

120 Nine-Piece Pentagon

Nine dissimilar pieces fit into a pentagonal tray. Six made of 1/4-inch end-grain zebrawood in 1996. A laser-cut version was made by Walt Hoppe and used in the IPP-17 puzzle exchange.

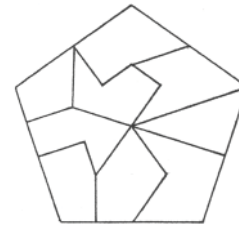

Nine-Piece Pentagon (#120) in zebrawood by Stewart Coffin



Nine-Piece Pentagon (#120) in walnut by Walt Hoppe

121 Pentagonal Star

Thirteen dissimilar pieces fit into a tray having the shape of a pentagonal star. The building blocks for each piece in this and #120 are 36-54-90-degree triangles. Four made of ¼-inch end-grain zebrawood in 1996. Some laser-cut versions have also been made by Walt Hoppe.

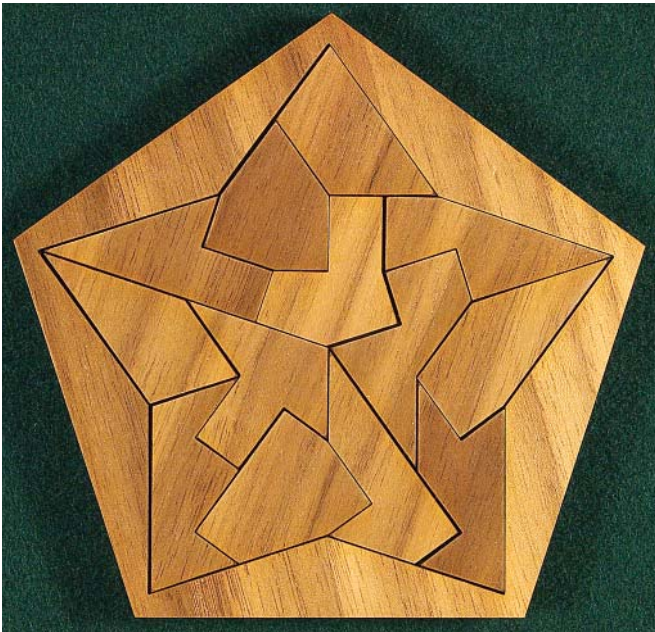
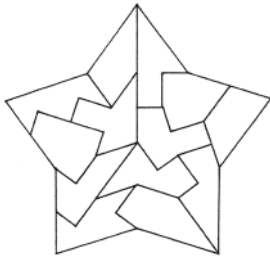

Pentagonal Star (#121) by Walt Hoppe

122 Rhombic Blocks

Nine pieces, representing all the ways that three rhombic blocks can be joined together, fit into a hexagonal tray with cover. Analysis by computer has shown 14 solutions. Made in nine contrasting fancy woods, which are identified on the printed solution. Ten made in 1996.



Rhombic Blocks (#122) by Stewart Coffin

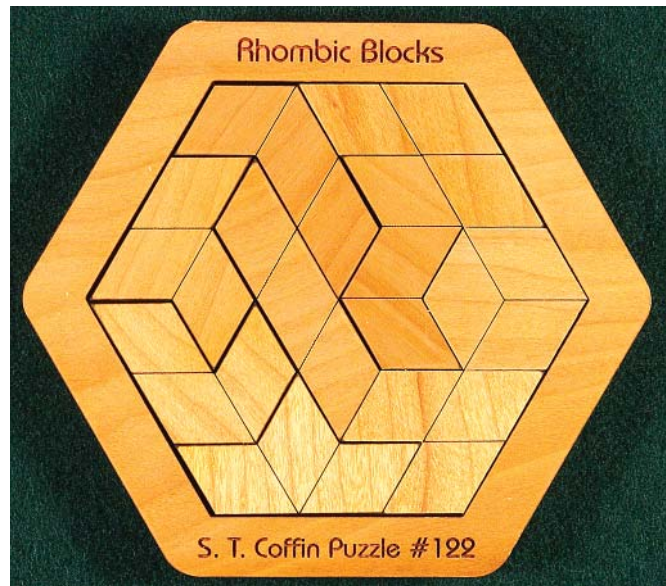

Rhombic Blocks (#122) in cherry by Walt Hoppe

123 Rock Pile a.k.a Abel's Chimney

A solid block that is nearly cubic but actually slightly rectangular is dissected by three diagonal cuts to make eight puzzle pieces that fit snugly into the nearly cubic box, but alas with two smaller blocks that are alike left over. The problem is to rearrange the blocks so that the leftover blocks also fit in, and all ten still fit snugly into the box. It can be quite frustrating if you don't know either the easy trick for rearranging or the marked code. The two layers of blocks without the two small blocks are marked **R O C K P I L E**. Knowing that, you can always restore it to the original packing. Four were made in 1997 with the aid of my 20-inch band saw, which I no longer have. The pieces were interchanged between sets so that matching the wood grain would be of no help. I probably got more entertainment from figuring out the exact saw cuts than most persons would get from trying to solve it.

Note the two small blocks in the center of the assembly visible in the photograph.

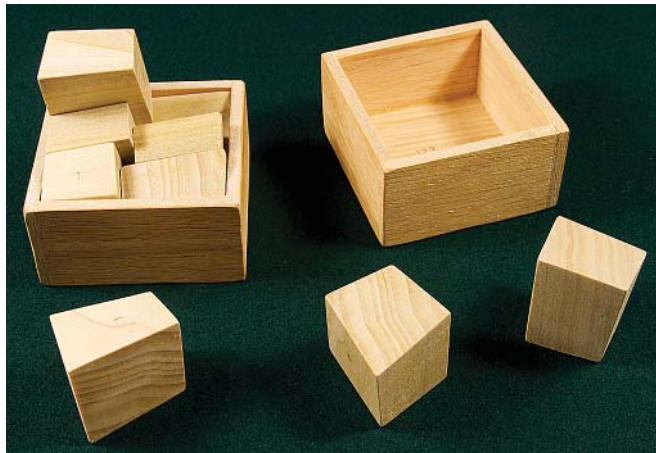
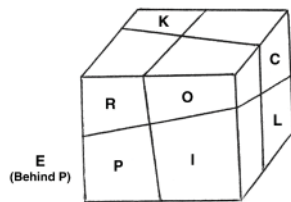

Rock Pile (#123) in maple with Philippine mahogany plywood box by Stewart Coffin

124 R-D-16

Not a new drug, this is a continuation of the family represented by **Four-Piece Pyramid (#26)**, **Octahedral Cluster (#31)** or **Five-Piece Octahedral Cluster (#31-A)**. Sixteen rhombic dodecahedron blocks are joined together to make four puzzle pieces that assemble into an interlocking polyhedral cluster, which could be described as the **Four-Piece Pyramid** without the four vertex blocks. Four in multicolored fancy woods were made in 1997, actually using edge-beveled cubes instead. The design, not previously published, is indicated by the schematic drawing.

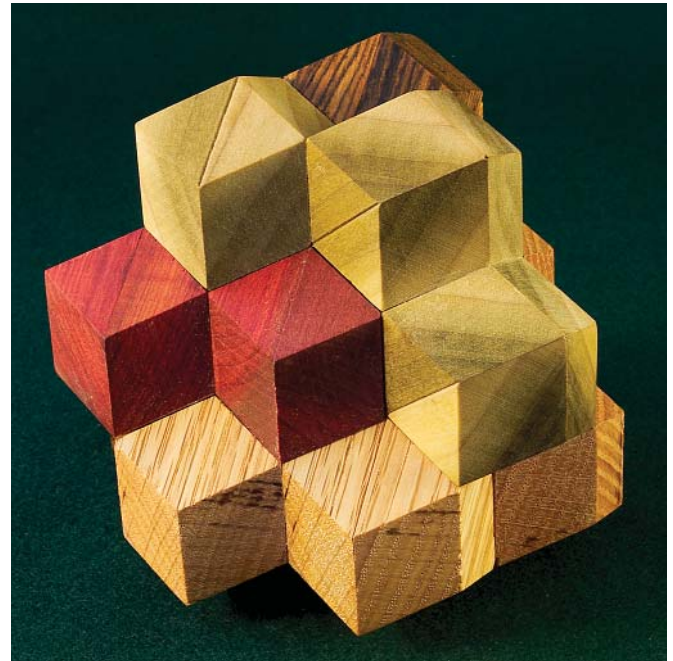
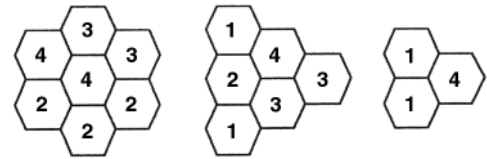

R-D-16 (#124) made from rhombic dodecahedron blocks, in bloodwood, bocote, poplar & oak by Stewart Coffin



R-D-16 (#124) made from edge-beveled cubes, in white lauan by Stewart Coffin

125 Archimedes Tile

The idea was to dissect a tiling of the plane made up of squares and equilateral triangles into puzzle pieces that fit together to form an approximate square. The one experimental design is shown. This idea never got beyond the experimental stage and one rough model. I decided the tray was too complicated to make.

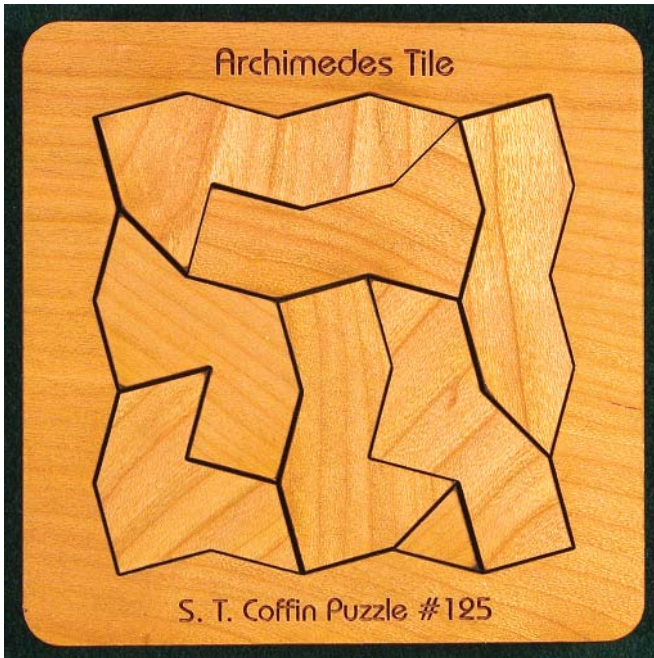
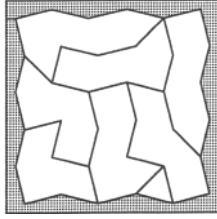

Archimedes Tile (#125) in cherry by Walt Hoppe

126 Stew's Scrap Pile

This is a standard six-piece burr and diagonal burr all combined into one. It was made in padauk, maple, and mahogany and used in the IPP-17 puzzle exchange.

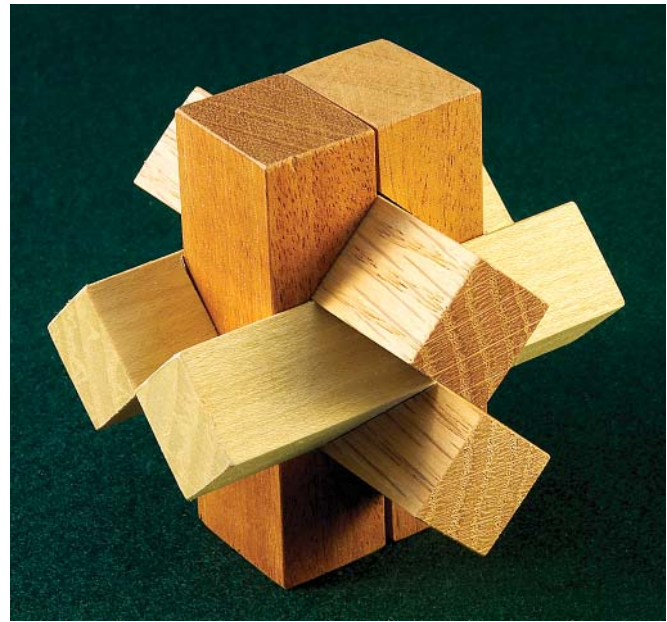
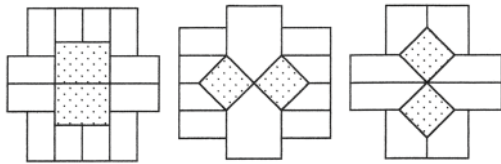

Stew's Scrap Pile (#126) in mahogany, maple & oak by Stewart Coffin

127 Make Room

Eight rectangular blocks appear to fit snugly into a $7 \times 9 \times 11$ box, and the problem is to fit the leftover ninth block in. One made in 1997. The eight blocks are: $2 \times 5 \times 6$, $3 \times 4 \times 5$, $3 \times 4 \times 6$, $3 \times 4 \times 7$, $3 \times 5 \times 6$, $4 \times 4 \times 5$, $4 \times 5 \times 5$, $4 \times 5 \times 6$, and the leftover block is $2 \times 2 \times 5$.

127-A Make Room

This is a larger version of **Make Room** (#127) in a $9 \times 10 \times 11$ box. The blocks are: $2 \times 5 \times 6$, $3 \times 4 \times 5$, $3 \times 4 \times 6$, $3 \times 5 \times 6$, $4 \times 5 \times 7$, $4 \times 5 \times 8$, $4 \times 6 \times 7$, $5 \times 6 \times 7$, and the leftover block is again $2 \times 2 \times 5$. Used in the IPP-21 puzzle exchange.



Make Room (#127-A) in walnut & Plexiglas by Interlocking Puzzles

128 Combination Lock

This unusual design could perhaps be considered a modified **Rosebud** (#39), slightly different shape. More important, all six pieces are dissimilar. But its main claim to fame is that it combines baffling coordinate motion, combinatorial confusion, and serial interlock all in one design. How many other puzzles do you know with all three of those features? The **Rosebud Assembly Jig** (#39-A) can also be used here. Six made in 1997. Note the two mirror image pairs of pieces.

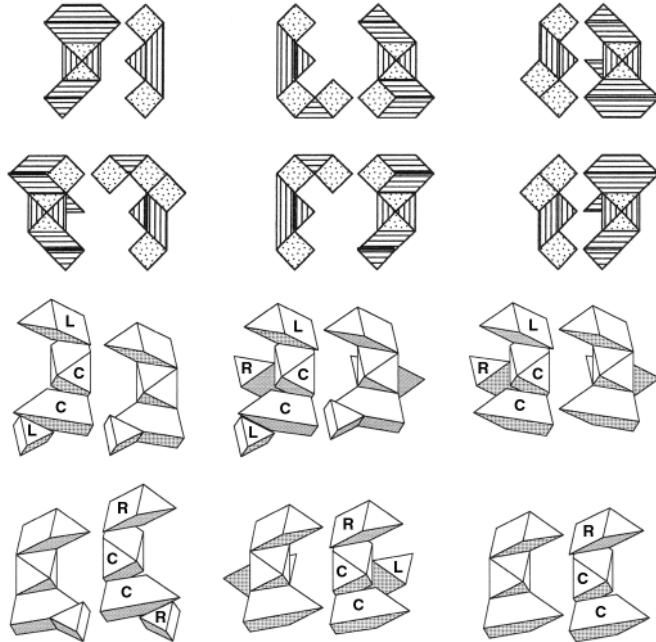

Combination Lock (#128) in cherry by Stewart Coffin

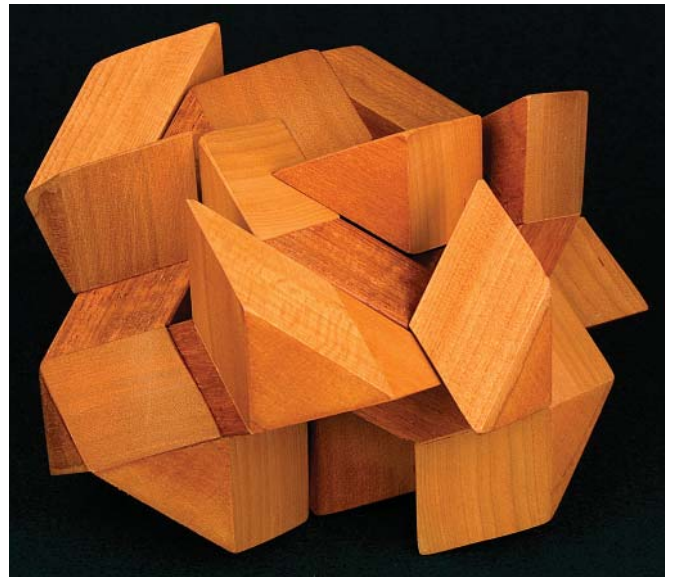

Combination Lock (#128) partially open

129 Dudd

The inspiration for this burr puzzle probably came from one that Bill Cutler designed many years ago. His was a totally symmetrical six-piece burr in which each piece had a pair of diagonal notches in the center. It turns out that half of those notches are unnecessary. This simple puzzle is confusing to assemble and difficult to disassemble. Six were made in 1997.

129-A Missing Notches

This particular version of **Dudd** (#129), has ten notches instead of six for even more confusion. Used in the IPP-18 puzzle exchange, made in cherry.

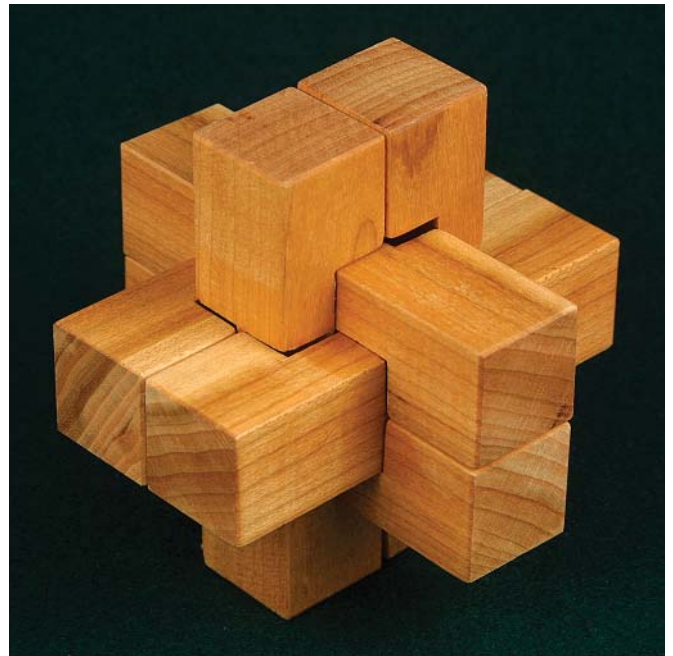

Missing Notches (#129-A) in cherry by Stewart Coffin

130 Slider

This is a six-piece diagonal burr made with sticks of rhomboid cross-section, 0.750×0.800 inches, and 84 degree angle. Uses two types of pieces, which are mirror image, three of each. I do find a record of the various angles involved in sawing the V notches, although the one model I have could be used to copy. The perplexing solution involves tricky coordinate motion. Five made of maple in 1997.

131 Six of Diamonds

Somewhat similar to **Slider** (#130) except that all six pieces are dissimilar. The sticks are rhombic cross-section, of size 0.800, and the angle is 80 degrees. Used in the IPP-18 puzzle exchange, made in padauk. It was reported that many experts were baffled by it.

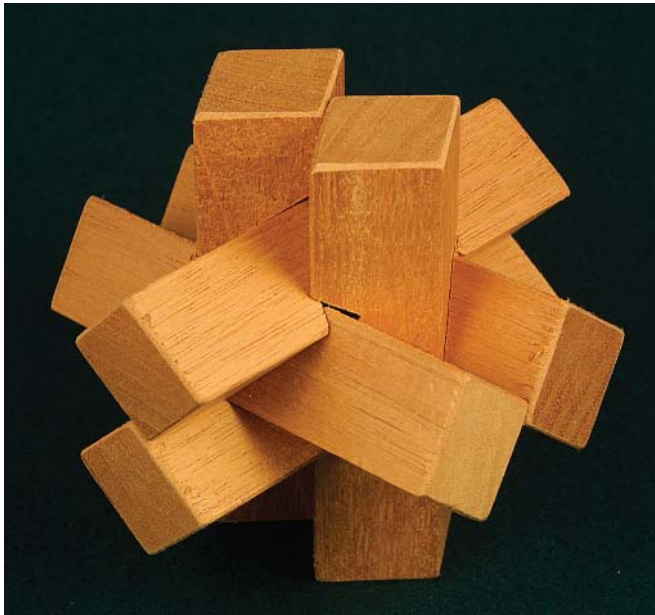

Six of Diamonds (#131) in mahogany by Stewart Coffin

132 Tectonic

This is a continuation of the family of crooked six-piece burrs that began with **Teddy Burr** (#96) and I thought had reached a state of perfection with **Slant Six** (#98-A). In this game, there are three types of crookedness. All of the previous designs involved one type or a combination of two types. This diabolical design uses all three. Used in the IPP-18 puzzle exchange, made in 3/4-inch maple.

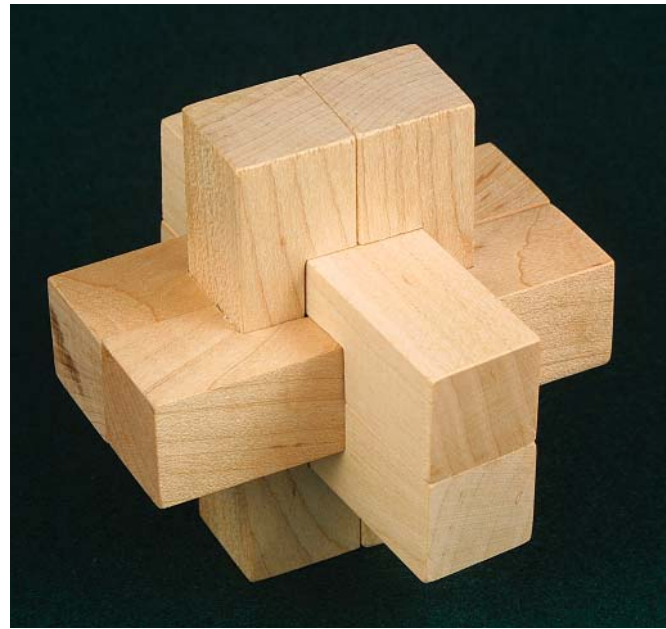

Tectonic (#132) in maple by Stewart Coffin

133 Few Tile

Four simple quadrilateral pieces fit into a rectangular tray. One of my most successful designs in this category, it has stumped experts. Used in the IPP-18 puzzle exchange, made of Baltic birch.



Few Tile (#133) in Baltic birch by Stewart Coffin

134 Outhouse

Five blocks fit into a square tray that has a constricted opening on top. A slightly modified version (with different name) was made in England and used in the IPP-19 puzzle exchange. Unfortunately either design error or inaccuracy in manufacture allowed easier solutions that entirely defeated the scheme of the design. In my original design, after many attempts, I think Edward Hordern and I managed to iron out all of the false solutions. The intended one involved a tricky coordinate motion of four pieces in order to insert the last piece.

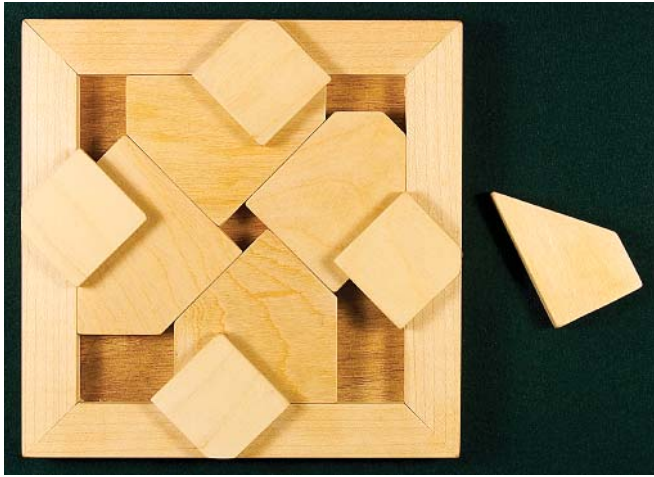

Outhouse (#134) in Baltic birch by Stewart Coffin

135 No Name

Seven irregular hexagons fit into a hexagonal tray. The idea was to find a design that had only one solution, but I never was able to find one. Consequently this puzzle never got beyond the conceptual stage, and I have doubts that the idea has much potential.



No Name (#135) in cherry by Walt Hoppe

136 Tangram Plus

It looks pretty much like the familiar seven-piece Tangram, but refuses to fit into the square tray in the usual way. The rhomboid piece is too long. There is also a slightly different version that had an extra small rhomboid piece. But for an improved version, see **Eight-Piece Tangram (#155)**.

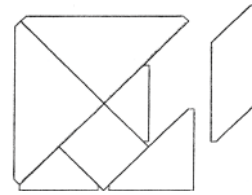

Tangram Plus (#136) by Stewart Coffin

136-A Tangram Plus

This is an alternate version of **Tangram Plus (#136)**. But now the rhomboid piece is too fat! This one may have been in the IPP-19 puzzle exchange.



Tangram Plus (#136-A) in cherry by Walt Hoppe

137 Engelberg Square

Six polyomino-type pieces, made up of 25 square blocks with corners beveled to slightly octagonal, fit into a square tray. So named because the final version was arrived at while on a hiking trip in Engelberg, Switzerland, assisted by one of our fellow Elderhostelers, Betty Anthony. The underlying theme is a set of pieces with 25 blocks that do not have a 5x5 solution and a tray just large enough for a single hybrid solution. Beveling the corners allows for a much smaller tray than otherwise possible. Six made of teak in 1998.

A modified version of the **Engelberg Square** was designed by Nick Baxter and used in the IPP-19 puzzle exchange. Nick had a slightly different objective, to find the smallest tray allowing a unique arrangement of 26 blocks. It turns out that the trays for both are about the same size.



Engelberg Square (#137) in teak by Stewart Coffin

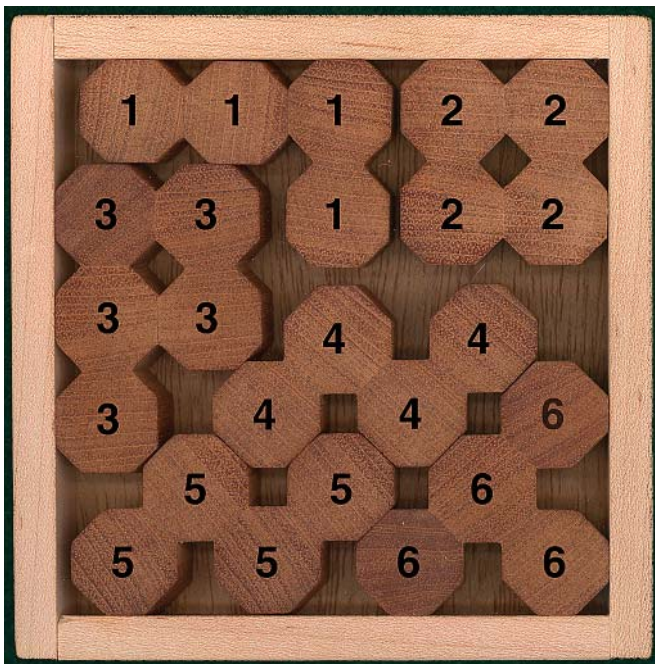

Engelberg Square (#137) solution



Engelberg Square (#137) by Walt Hoppe

The variation used in Nick's exchange puzzle started with a 26-block puzzle with one of the corner blocks removed, but still having a single solution. The result is a puzzle that appears to be a 25-block puzzle with the unintuitive solution requiring solver to "waste" one full space in one of the corners.

Walt Hoppe's laser-cut version was copied from an original where the L piece (number 1 in the first two solutions) had come apart into two pieces with two blocks each.

In all versions of this puzzle, very close tolerances and changes in humidity sometimes prevent the correct solution and allow for ones not planned

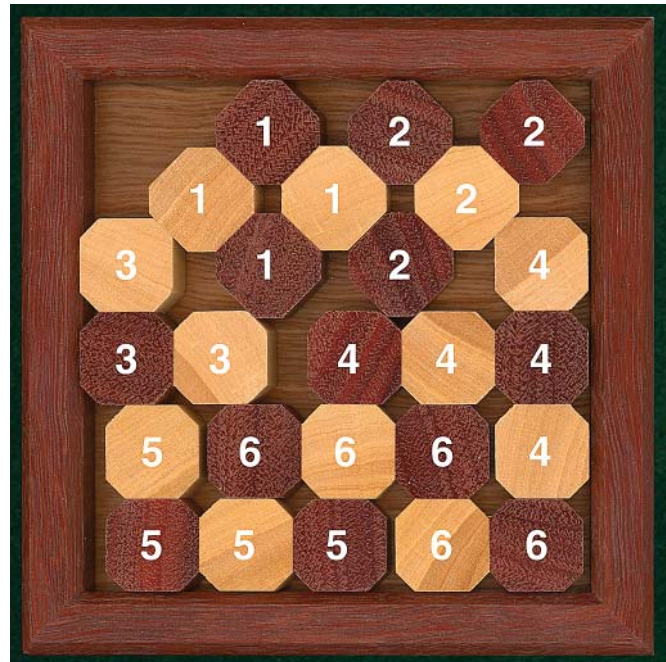

Engelberg Square (#137) Nick Baxter's modified version by Interlocking Puzzles

138 Piggy Box

This is a sort of shifting block packing puzzle. Five types of pieces are made up of cubes joined together different ways (poly-cubes). The illustrations indicates the number of each piece in the set. The rectangular box has a rectangular hole in the top, and the problem is to fit all the pieces in. The instruction sheet gives five different problems of varying difficulty using different sets of pieces. Eight made in 1998. I don't get a whole lot of feedback, so I don't know how much recreation this puzzle provided to others, but I sure had fun working out the various problems, with others probably waiting to be discovered.

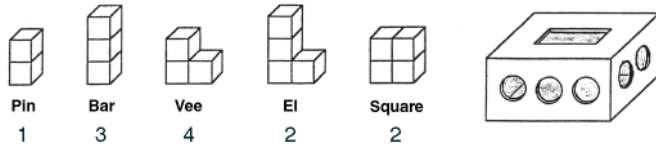

Piggy Box (#138) in maple with Baltic birch box by Stewart Coffin

139 No Name

Nine puzzle pieces made up of 54 triangular tiles joined together different ways fit into a hexagonal tray. This set uses all possible non-symmetrical puzzle pieces through size six plus two pieces of size seven. The design objective was to find two size-seven pieces from the set of 18 non-symmetrical ones that would yield a unique solution. My first try is shown in the left drawing. Alas, Bill Cutler's computer analysis turned up 146 solutions. The problem was further investigated by Mike Beeler, and he found there was no combination with unique solution. The closest, he reported, was the one shown right drawing with three solutions. That is as far as this project went.

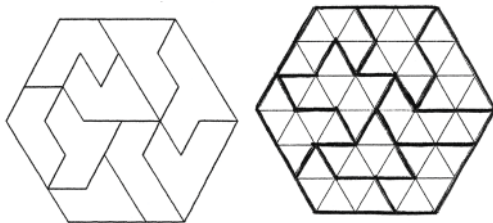

140 Sticky Sticks

This is a redesign of **Stucksticks** (#71). It again uses four compound pieces, but in this design they are all dissimilar. There are two solutions. Five made of four contrasting woods in 1998, the use of which is a big help in solving this otherwise very difficult puzzle. See improved version, **Seven-Piece Hexsticks, Improved** (#159-A).

141 Isosceles

Ten puzzle pieces made up of isosceles right triangles joined together different ways fit into a square tray. Two contrasting woods used for artistic effect. Six made in 1998.

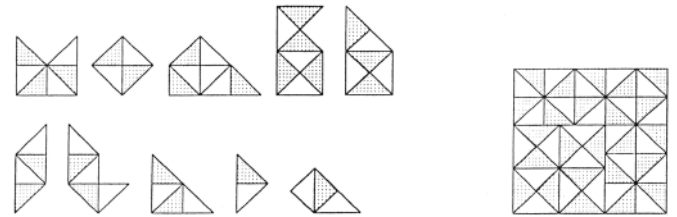

Isosceles (#141) by Stewart Coffin

142 Octahedron

Thirty blocks that are squares with corners beveled are joined together to make seven puzzle pieces. They fit into a tray that could be described as a flattened octagon. A lot of analysis went into this design by Jerry Slocum, Mike Beeler, and others using the two rough models that I made in 1998, but nothing much came of it except false solutions unless the pieces and tray are precisely made. Consider this an aborted design.

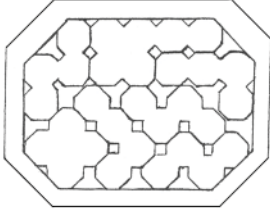

Octahedron (#142) in walnut by Walt Hoppe

Note: Beginning in January 1999, my serial listing of AP-ART designs continues the same as before, but with the added by-name "Castle Creations." This reflects not only a change in location from Lincoln to Andover, but also a change in operations from a woodworking shop to a part-time hobby mostly involving designing, model making, and publishing.

143 Checkout

Somewhat the same idea as **Isosceles** (#141), but only nine pieces, and of course a different scheme. This was used in the IPP-20 puzzle exchange, beautifully crafted in maple and walnut by Tom Lensch.

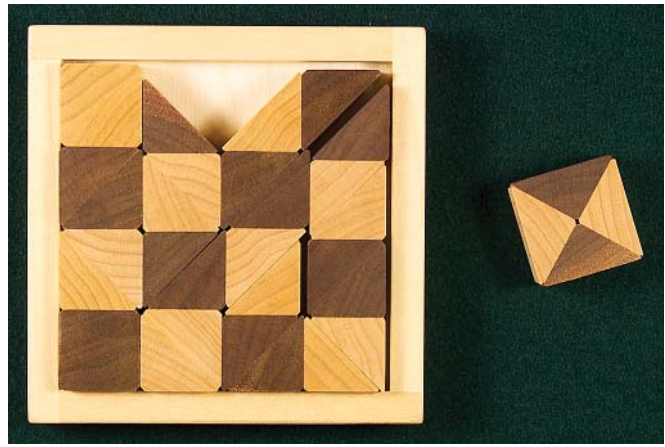
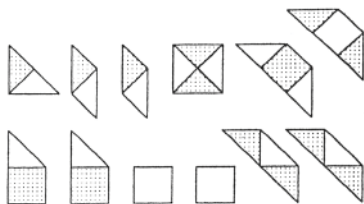

Checkout (#143) in maple & walnut by Tom Lensch

144 Windmill

Seventeen pieces made up of 68 isosceles right triangles of two slightly different sizes fit into a square tray. In my intended solution, which I thought was unique, contrasting woods are used to create a windmill pattern. Then Bill Cutler analyzed this puzzle by computer and found a second solution, with five interior pieces rearranged. Surprisingly, the windmill pattern remains intact. A laser-cut version was made by Walt Hoppe and used in the IPP-19 puzzle exchange.

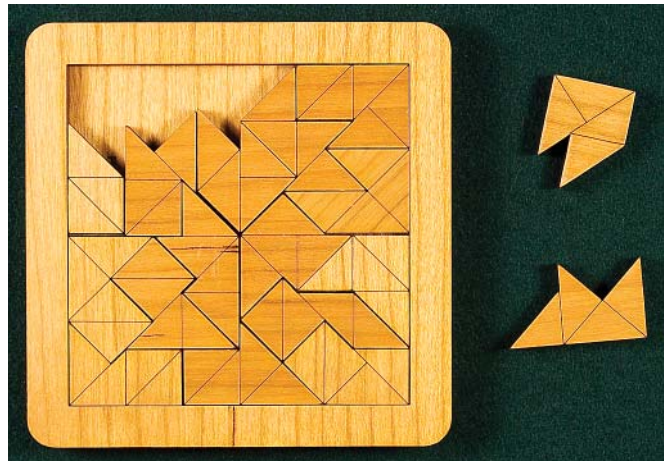
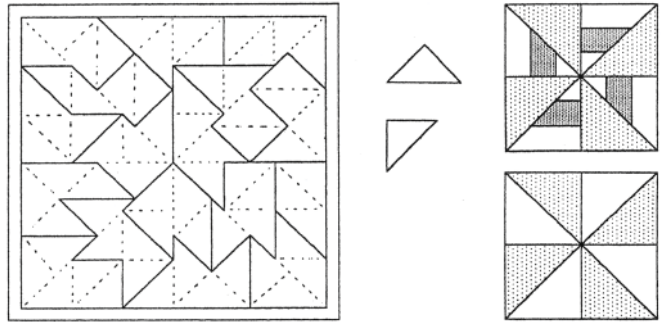

Windmill (#144) in cherry by Walt Hoppe

145 Lemon

Ten puzzle pieces made up of equilateral triangles and isosceles right triangles, 20 of each, fit into a tray that is sort of elliptical. There are at least two solutions. A few were made in 1998-1999.

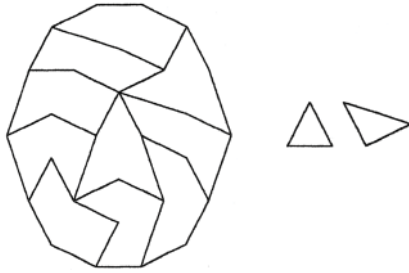

Lemon (#145) by Stewart Coffin

146 Lime

A companion to the **Lemon** (#145), except that the ten puzzle pieces are made up of isosceles right triangles and 30-60-90 triangles. There are several solutions. A laser-cut version was made by Walt Hoppe and used in the IPP-19 puzzle exchange.

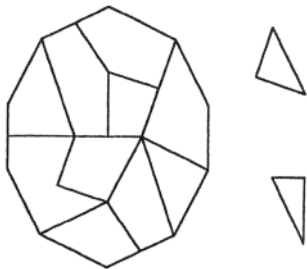

Lime (#146) in walnut & cherry by Walt Hoppe

147 Pineapple

Similar to **Lemon** (#145) and **Lime** (#146), but larger and more complicated, with 13 pieces made up of squares and equilateral triangles. A laser-cut version of this puzzle has been made by Walt Hoppe.

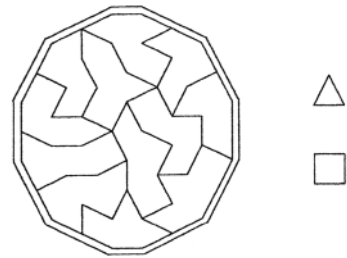

Pineapple (#147) by Stewart Coffin

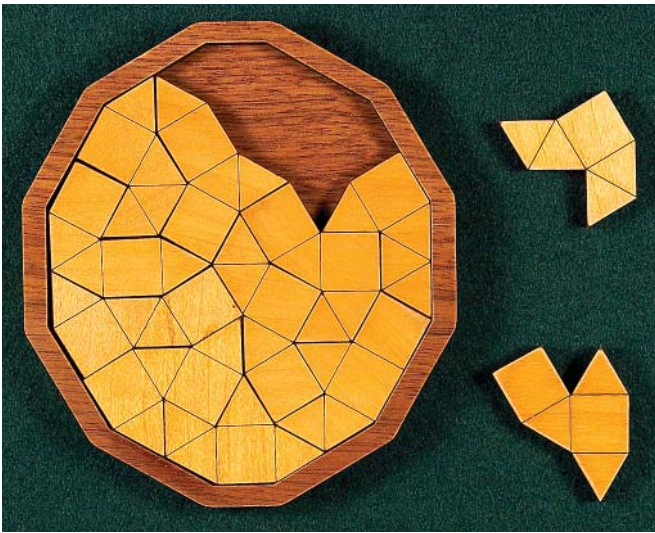

Pineapple (#147) in cherry & walnut by Walt Hoppe

148 Fourteen-Piece Square

This little novelty, shown here full scale, was made in mahogany as a handout for an Elderhostel puzzle workshop in Lenox, MA, April 1999. About 40 made. It was intended to have essentially one solution, but unless very accurately made there tended to be multiple solutions.

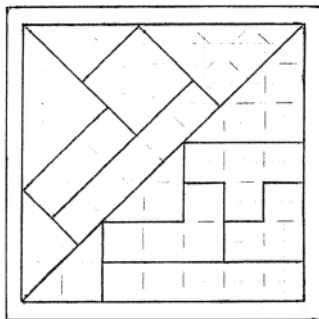

149 Five-Piece Garnet

Similar to the original **Garnet** (#60) in contrasting fancy woods, but 20% larger and five pieces rather than six. I made two in 1999, keeping one to retain as a pattern and selling the other. Perhaps one of these could be loaned or photographed disassembled if anyone wants to make copies, but I think I prefer the original six-piece version. This one is a little more confusing to disassemble.

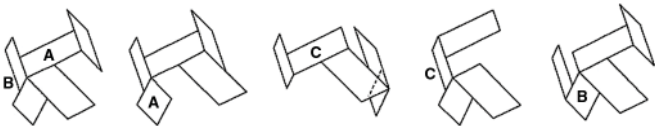

Five-Piece Garnet (#149) by Stewart Coffin

150 Five-Piece Garnet with Coordinate Motion a. k. a. Knife Attack!

Looks very much like the **Five-Piece Garnet** (#149), but the design incorporates coordinate motion, confusing to disassemble and very difficult to assemble. One made in 1999. Otherwise same comments apply.

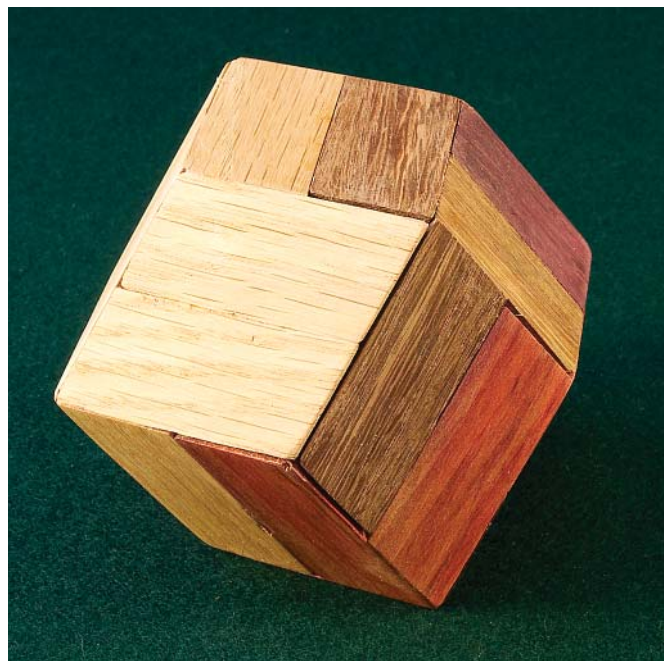
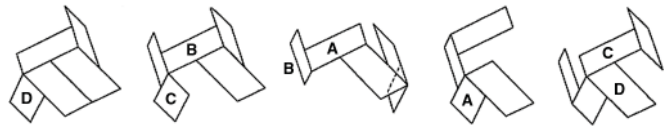

Five-Piece Garnet with Coordinate Motion (#150) by Stewart Coffin



*Me, demonstrating how to disassemble the **Five-Piece Garnet with Coordinate Motion** (#150) and why it is also known as **Knife Attack**!*

151 Two Tiers with Scorpius Outer Shell

The concept of two tiers has already been explained in **Two Tiers** (#75-A), and also in *The Puzzling World of Polyhedral Dissections*, Chapter 20. In this design, the outer shell is a **Scorpius** (#5), and the inner is a **Garnet** (#60). It was difficult to make and so I made only two, one of which I still have. Same comments as **Five-Piece Garnet with Coordinate Motion** (#150) apply if anyone wants to make copies.



Two Tiers with Scorpius Outer Shell (#151) in oak by Stewart Coffin



Two Tiers with Scorpius Outer Shell (#151) partially disassembled

152 Seven-Piece Scrambled Scorpius

The name indicates what this was supposed to be. Several experimental design variations were tried, but none was judged to be very satisfactory, so consider this another aborted design.

153-A The Trap

This design started out as #153 but underwent several minor changes until arriving at the one shown here as #153-A. When accurately made it is a very satisfactory puzzle. There is only one solution but at least seven ways that almost fit. This illustration is of a model in maple and cherry. It has been reproduced in cardboard.

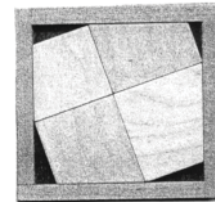

153-B The Trap a. k. a. Drop In

The “B” version of this puzzle has a Plexiglas cover and a slot in one side of the tray through which the pieces must be inserted, making it more confusing. A few were made in 2002. Used in the IPP-23 puzzle exchange as **Drop In**.

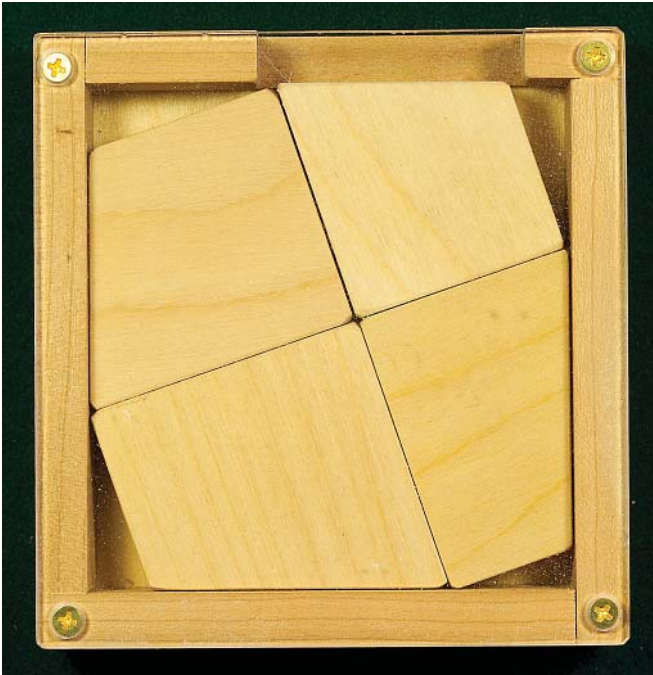

The Trap (#153-B) Stewart Coffin



Drop In (#153-B) by Saul Bobroff

154 No Name

This was to be a puzzle similar to **Outhouse** (#134), except that the solution would require coordinate rotation. A satisfactory design was never found, and it remains an unfinished project.

155 Eight-Piece Tangram

This could be considered an improved version of **Tangram Plus** (#136). The idea is simple enough. Everyone is familiar with the seven-piece Tangram. So what do you do with the extra small triangle? A laser-cut version of this puzzle has been made by Walt Hoppe and used in the IPP-20 puzzle exchange.

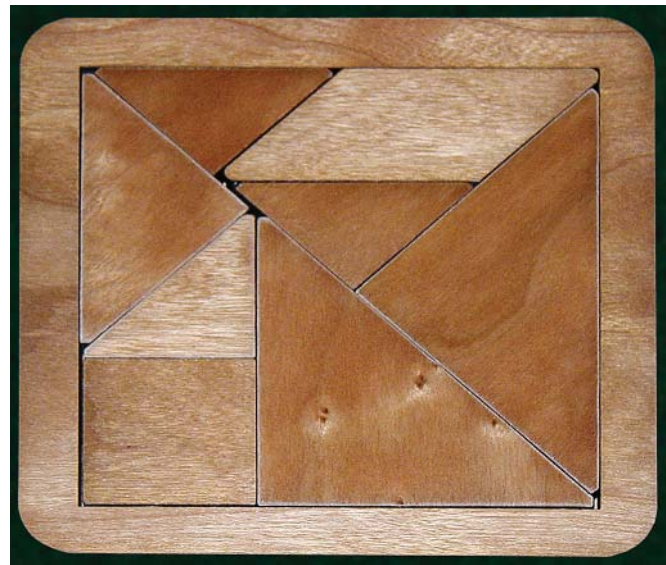
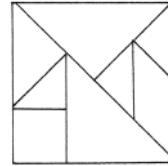

Eight-Piece Tangram (#155) in cherry by Walt Hoppe

156 Sphinx

This could be considered a logical conclusion to the series that began with **Jupiter** (#7) and **Saturn** (#24). Twelve dissimilar pieces fit together one way only, and in essentially one order. This version, which is all in one kind of wood, is by far the most difficult. A couple were made in 2000.

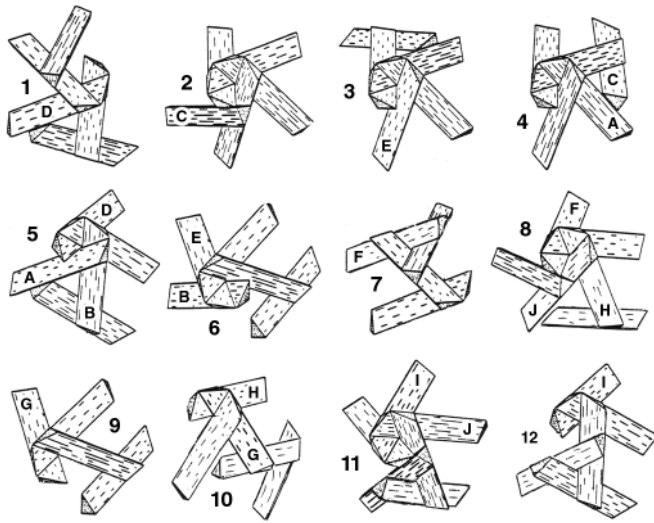

Sphinx (#156) in oak by Stewart Coffin

156-A Sphinx, 5 Woods

This version, and the others that follow, are mechanically identical but differ in the symmetrical arrangements of the colorful woods. This version uses five dissimilar woods in matched pairs, with the pairs arranged in what I call cubic symmetry. This greatly facilitates the solution. A few were made in 2000.

156-B Sphinx, 15 Woods

This version uses 15 dissimilar woods arranged in matched pairs, with the like pairs arranged opposite each other.

156-C Sphinx, 30 Woods

This version uses 30 dissimilar woods arranged in matched pairs. I finally managed to scrape together just enough different kinds of woods to make a few of these.



Sphinx (#156-C) in *pequia amarello*, *pernumbuco*, *fishtail oak*, *lacewood*, *goncalo alves*, *camphorwood*, *bloodwood*, *African olivewood*, *Nicaragua rosewood*, *Macassar ebony*, *Gaboon ebony*, *pink ivory*, *wenge*, *wenge (bleached)*, *bocote*, *cocobolo*, *morado*, *tulipwood*, *black palm*, *zebrawood*, *padauk*, *koa*, *canarywood*, *narra rosewood*, *jatoba (Brazilian cherry)*, *imbua (Brazilian walnut)*, *purpleheart*, *bubinga*, *bois de rose* & *tarara* by Bart Buie—see next page for view of the other side



Sphinx (#156-C) in pequia amarello, pernumbuco, fishtail oak, lacewood, gonzalo alves, camphorwood, bloodwood, African olivewood, Nicaragua rosewood, Macassar ebony, Gaboon ebony, pink ivory, wenge, wenge (bleached), bocote, cocobolo, morado, tulipwood, black palm, zebrawood, padauk, koa, canarywood, narra rosewood, jatoba (Brazilian cherry), imbua (Brazilian walnut), purpleheart, bubinga, bois de rose & tarara by Bart Buie—see previous page for view of the other side

157 Multi-colored Egyptian in Four Colors

The name is self-descriptive.



Multi-colored Egyptian in Four Colors (#157) poplar, oak, walnut & mahogany by Stewart Coffin

157-A Multi-Colored Egyptian in Three Colors

Likewise self-descriptive.

157-B Multi-Colored Egyptian in Two Colors.

Likewise self-descriptive.

157-C Multi-Colored Egyptian in Six Colors.

Likewise self-descriptive. In all of these the dissimilar woods are arranged symmetrically, which aids the solution. A few of each were made in 2000. On the accompanying instruction sheet they are renamed **The Recycled Puzzle**.



Multi-colored Egyptian in Six Colors (#157-C) in poplar, oak, walnut, carywood, mahogany & greenwood by Stewart Coffin

158 Augmented Scorpius with Coordinate motion.

This idea was investigated without much success, set aside, and then revived and improved to be renamed and renumbered as the **Shouldered Scorpius** (#166).

159 Seven-Piece Hexsticks

This is an improved version of **Sticky Sticks** (#140). It starts out with nine standard pieces and three odd (extra notch) pieces, as in **Hectix** (#25). Eight of the standard pieces are joined in pairs to make four T pieces. An odd and standard piece are also joined as shown to make a fifth T piece. The resulting seven puzzle pieces assemble one way only. This amazing and very difficult puzzle involves some non-linear moves to assemble. Yet as nearly as I can tell, the solution is geometrically perfect, meaning that no looseness or rounding of corners is required, unlike, for example, **Convolution** (#30), regardless of the length of the pieces. Ten were made of limba in 2000.

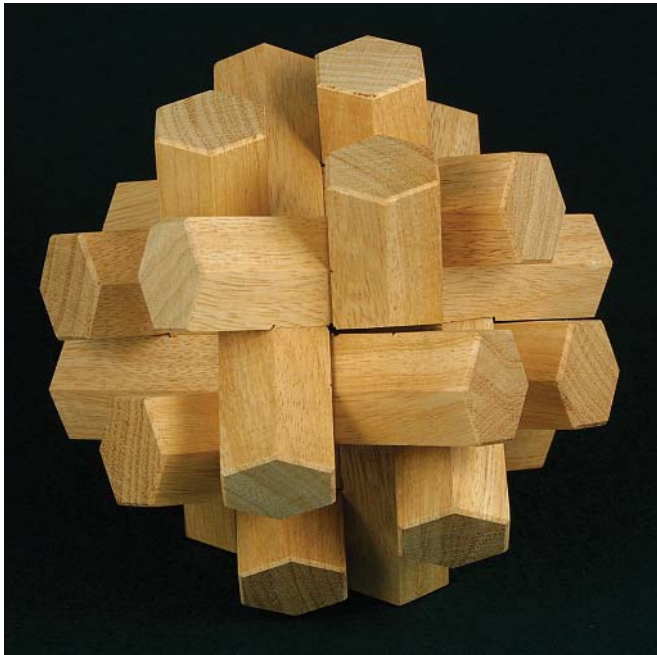
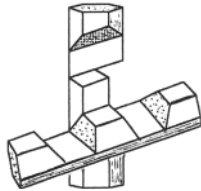

Seven-Piece Hexsticks (#159) in limba by Stewart Coffin

159-A Seven-Piece Hexsticks, Improved

After circling all around this puzzle design, with **Stucksticks** (#71), **Sticky Sticks** (#140) and **Seven-Piece Hexsticks** (#159), I believe I have finally stumbled upon the one optimum design. It uses the four dissimilar T pieces of **Sticky Sticks**, but with the addition of a fifth T piece made by joining two more standard pieces, so that two of the T pieces are alike. It does not require any sanding or shortening of pieces to assemble, and I believe there is only one solution. One made in 2003. The puzzle world awaits some enterprising woodworker to manufacture and sell this neat design.

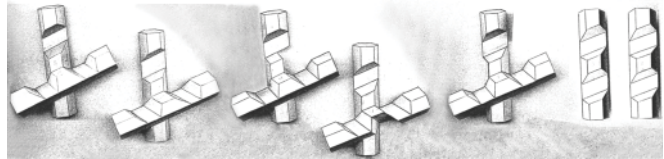

160 Venus

This is a variation of the old **Design No. 72** (#72), which has the assembled shape of the triacontahedron. In this version, a key piece must first be removed, making use of a slight thumbnail crack to locate it and pry it loose. It can also be found by looking for the piece with only three blocks. A second piece is next pulled out, allowing the puzzle to then come apart into two halves of four pieces each. All ten pieces are dissimilar and non-symmetrical, and ten contrasting fancy woods are used, one kind for each piece. The convex assembly allows the 30 faces to be finely finished on the belt sander. The solution is believed to be unique. However, there are probably better designs. I was never too happy with the idea of prying out the key piece.

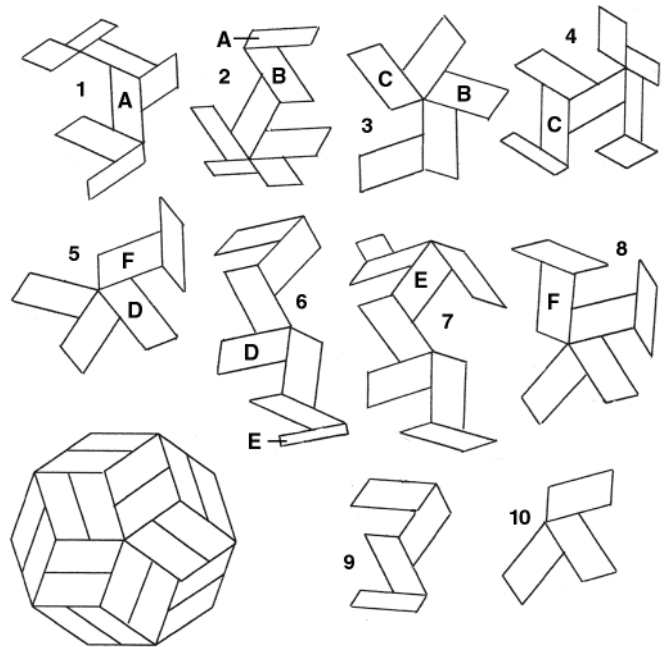

160-A Venus, 5 Woods

Same as **Venus** (#160) except two pieces of each wood.

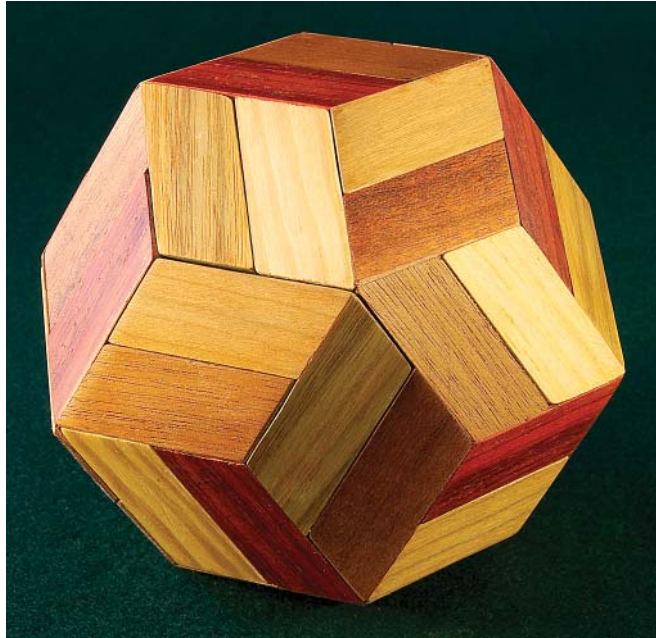

Venus, 5 Woods (#160-A) by Stewart Coffin

160-B Venus, 5 Woods with Matched Pairs

Unlike **Venus, 5 Woods** (#160-A), the dissimilar woods in this version are arranged symmetrically.

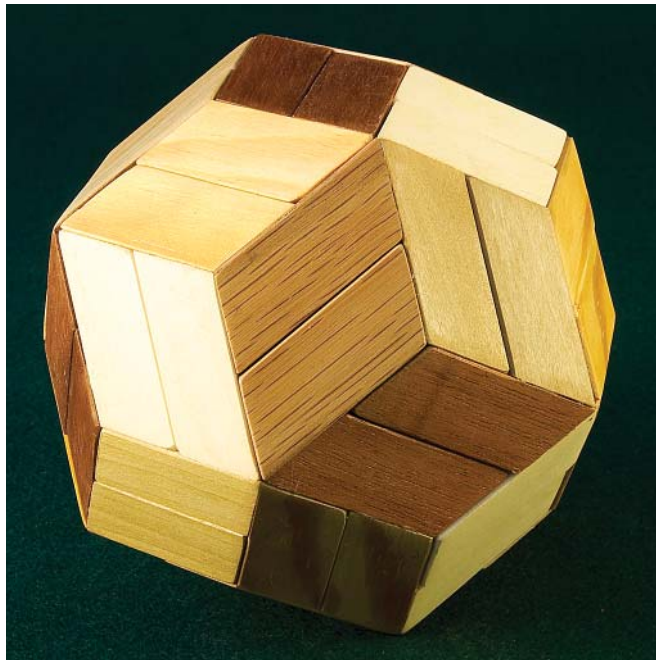

Venus, 5 Woods with Matched Pairs (#160-B) by Stewart Coffin

160-C Venus, 6 Woods

The six dissimilar woods are arranged in what I call double pin-wheel symmetry, making it somewhat easier than the **Venus, 5 Woods with Matched Pairs** (#160-B).

160-D Venus, One Wood

This would be the most difficult version, since the key piece is harder to find. None of this version have been made.

161 New Garnet

This is simply a new edition of the old **Garnet** (#60), more accurately made and 20% larger.

162 Scrambled Legs

Similar in principle to the **Scrambled Scorpion** (#23), but having the assembled shape of the third stellation of the rhombic dodecahedron. Just one more example of how the same basic idea gets recycled again and again, just by changing the superficial external shape. One made in four fancy woods was used as the logo prize award at IPP-20.

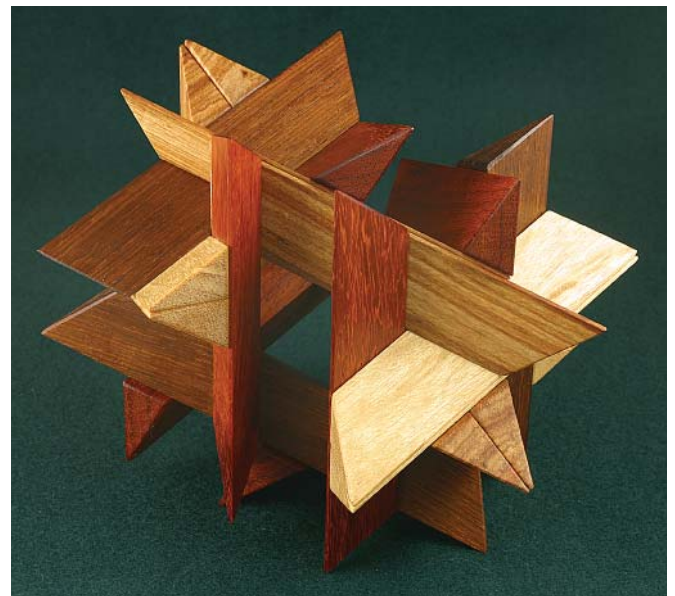

Scrambled Legs (#162) halves partially apart—see next page for assembled view



Scrambled Legs (#162) partially disassembled

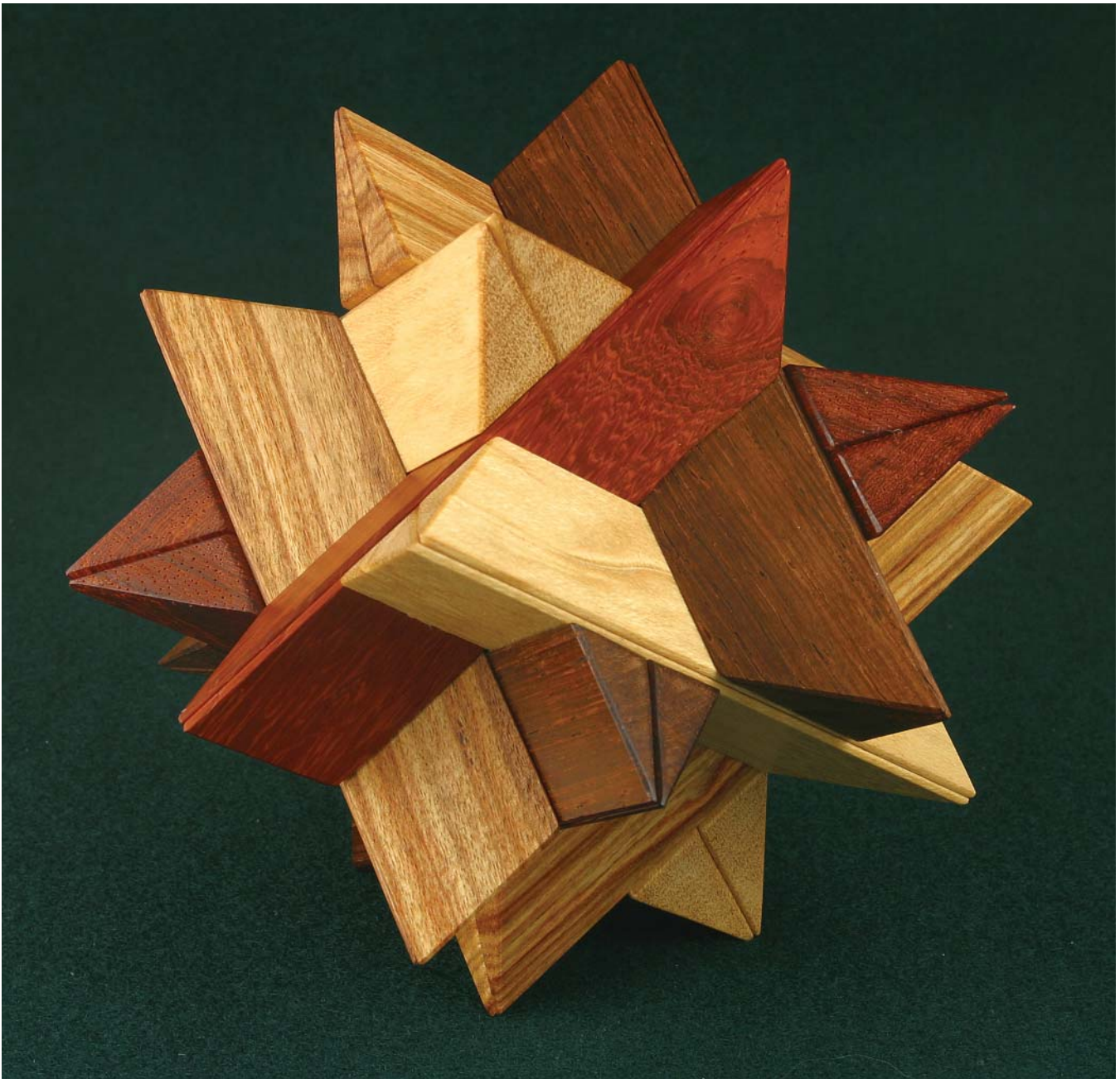

Scrambled Legs (#162) in padauk, yellowheart, Brazilian kingwood & canarywood by Bart Buie—see previous page for other views

163 No Name

Five rectangular blocks fit into a rectangular tray. This was an uninspired design to begin with, and no practical design was found. Whole idea shelved.

164 Scrambled Scorpius, 4 Woods

More colorful than the original **Scrambled Scorpius** (#23) because of the four contrasting fancy woods, and easier to solve because of the hints provided by the color symmetry.



Scrambled Scorpius, 4 Woods (#164) in oak, cherry, walnut & padauk by Stewart Coffin

164-A Scrambled Scorpius, 6 Woods

A different wood for each piece, so more colorful than the original **Scrambled Scorpius** (#23) but just as difficult.

164-B Scrambled Scorpius, 6 Woods

In this version, the six fancy woods are arranged symmetrically with no like colors touching, so knowing that it is somewhat easier than **Scrambled Scorpius, 6 Woods** (#164-A).

165 Split Star, Simplified

This modified version of the **Split Star** (#75) is easier to make than the original and also stronger, since the inner and outer blocks are joined by full faces rather than half faces. This geometry lends itself to sculptural recreations by selectively omitting some of the outer blocks, as in the variations listed. The names should be self-descriptive.

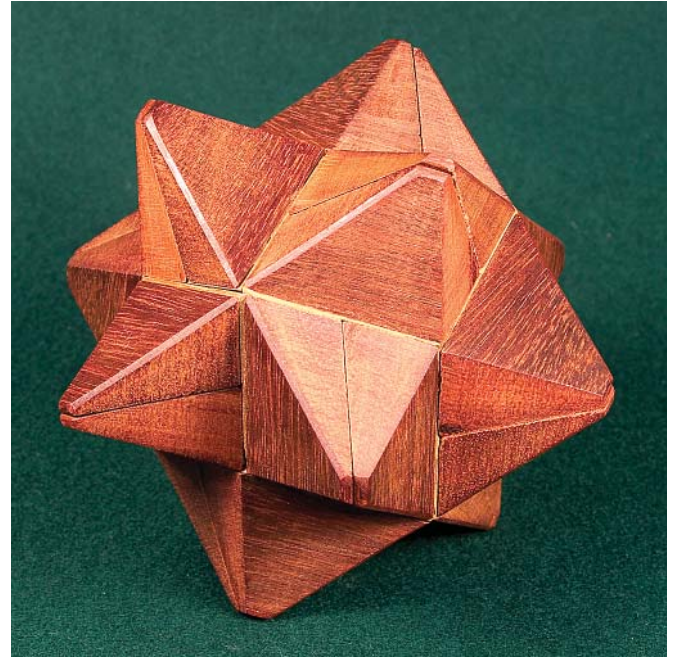

Split Star, Simplified (#165) in padauk by Stewart Coffin

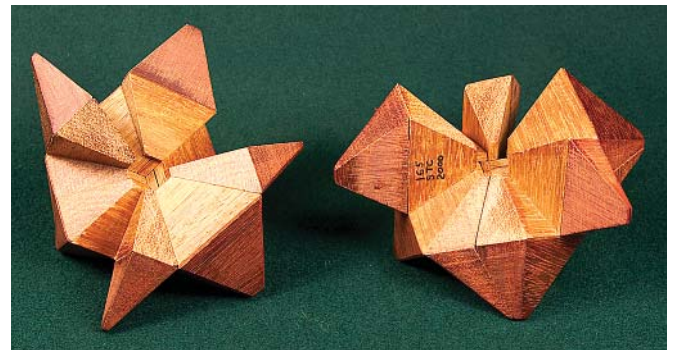

Split Star, Simplified (#165) with halves separated

The following **Split Star, Simplified** (#165) is part of a set that includes the following diminished versions.

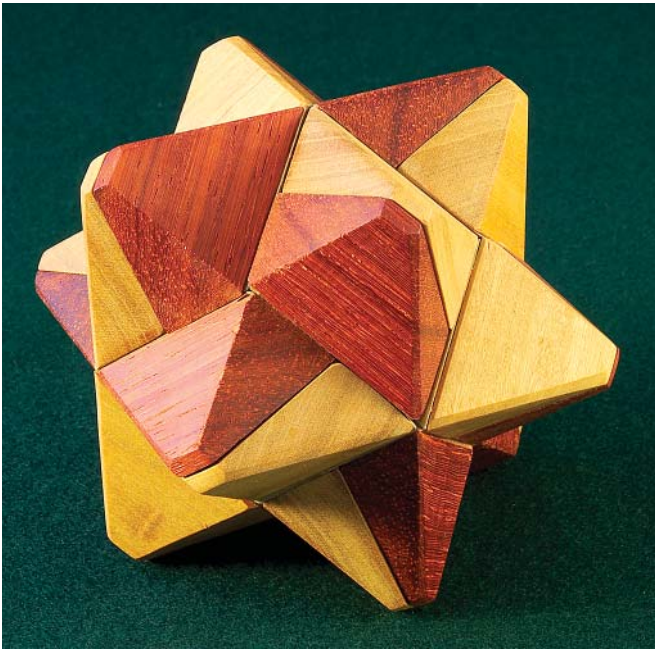

Split Star, Simplified (#165) in padauk & satinwood by Stewart Coffin

165-A Diminished Split Star, Hexagonal Column

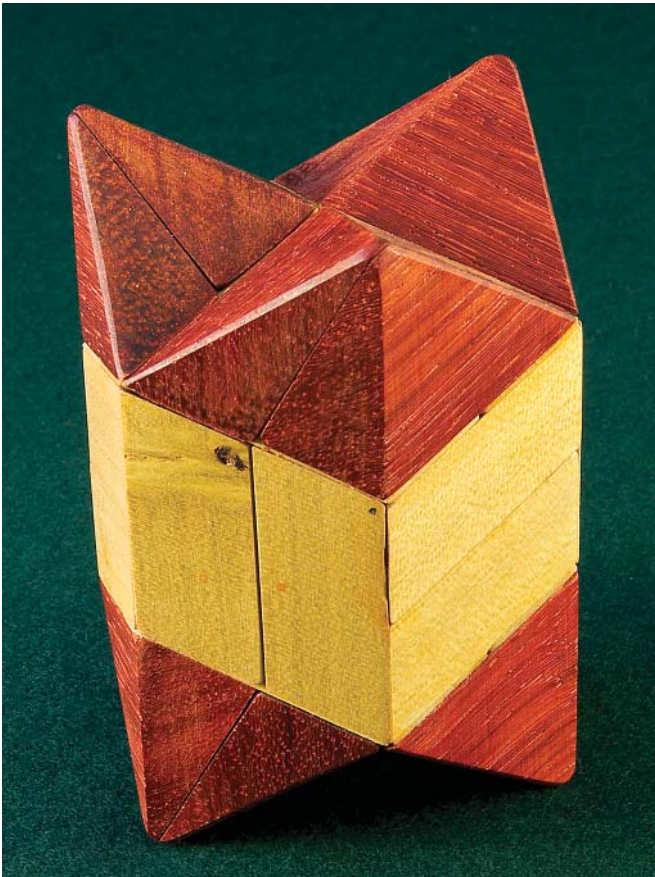

Diminished Split Star, Hexagonal Column (#165-A) in padauk & satinwood by Stewart Coffin

165-B Diminished Split Star, Square Column

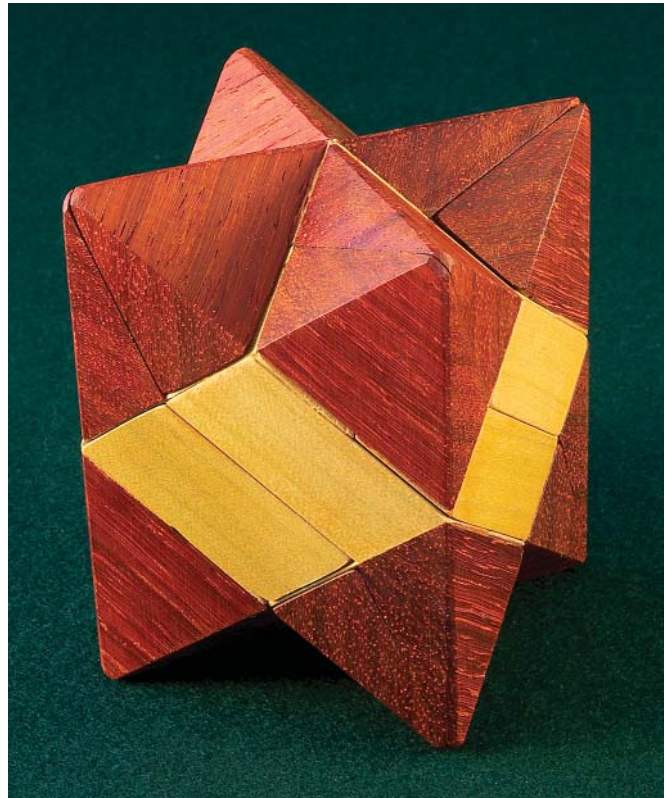

Diminished Split Star, Square Column (#165-B) in padauk & satinwood by Stewart Coffin

165-C Diminished Split Star, Octahedral

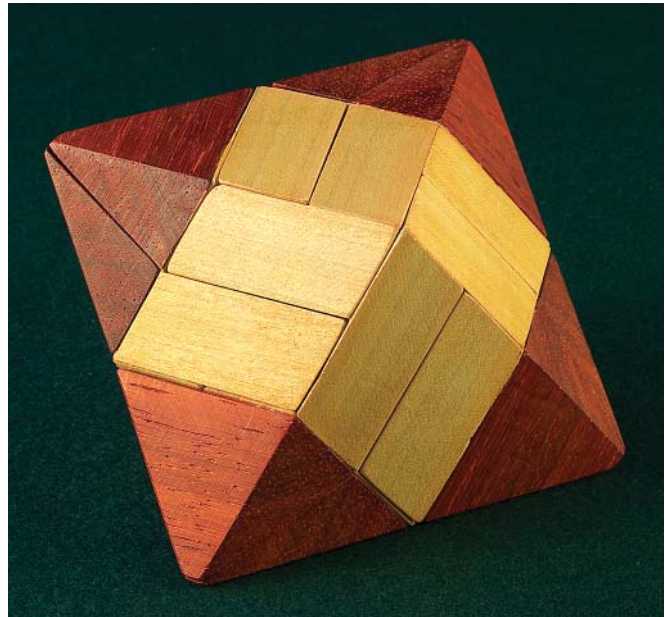

Diminished Split Star, Octahedral (#165-C) in padauk & satinwood by Stewart Coffin

165-D Diminished Split Star, Triangular



Diminished Split Star, Triangular (#165-D) in padauk & satinwood by Stewart Coffin

165-E Diminished Split Star, Six-Pointed Star

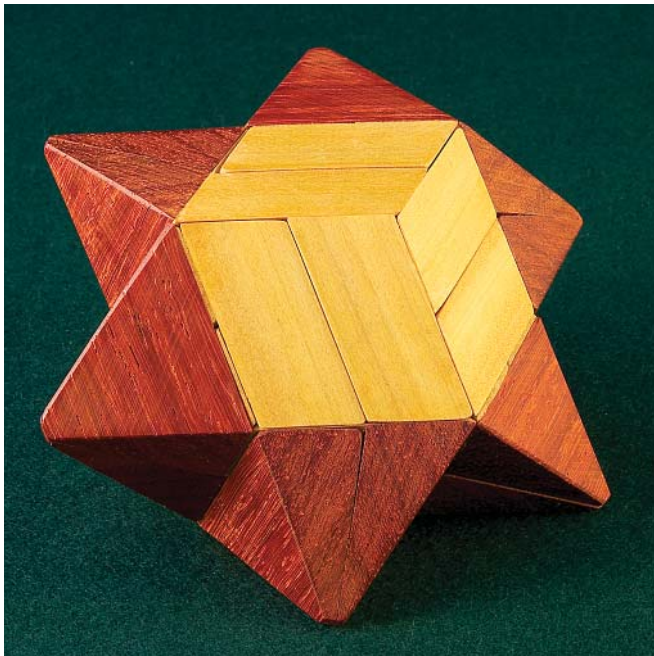

Diminished Split Star, Six-Pointed Star (#165-E) in padauk & satinwood by Stewart Coffin

166 Shouldered Scorpius, Simple Version

Resembles the old **Scorpius** (#5), but the added shoulders restrict movement in the first step of disassembly to separation into two halves along one axis only. Also called **Shouldered Spider Slider** on the instruction sheet.

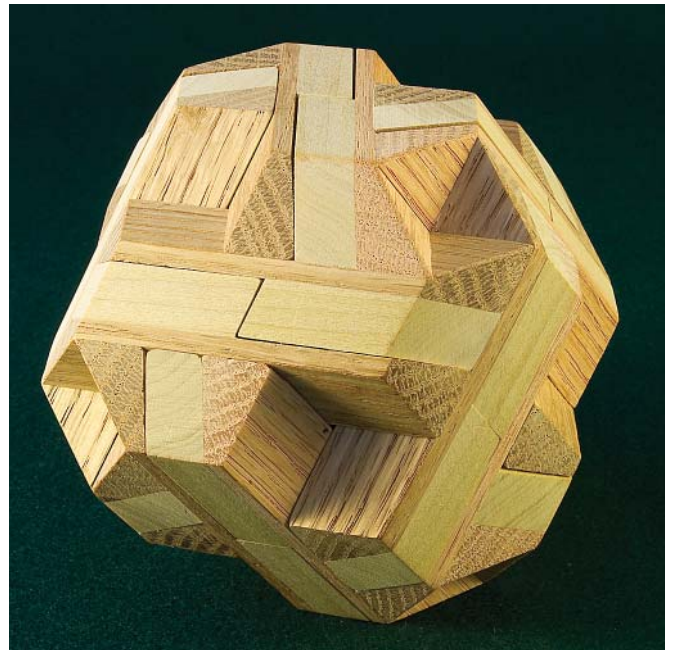
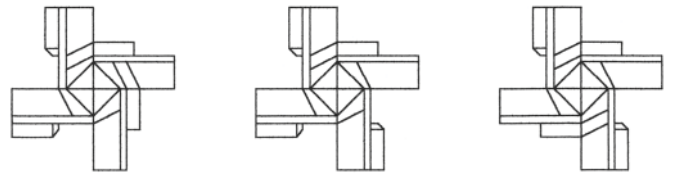

Shouldered Scorpius, Simple Version (#166) in oak & poplar by Stewart Coffin

166-A Shouldered Scorpius, Three Plus Three Version

All six pieces are identical but non-symmetrical. Tricky solution requires coordinate motion. My favorite of the three.

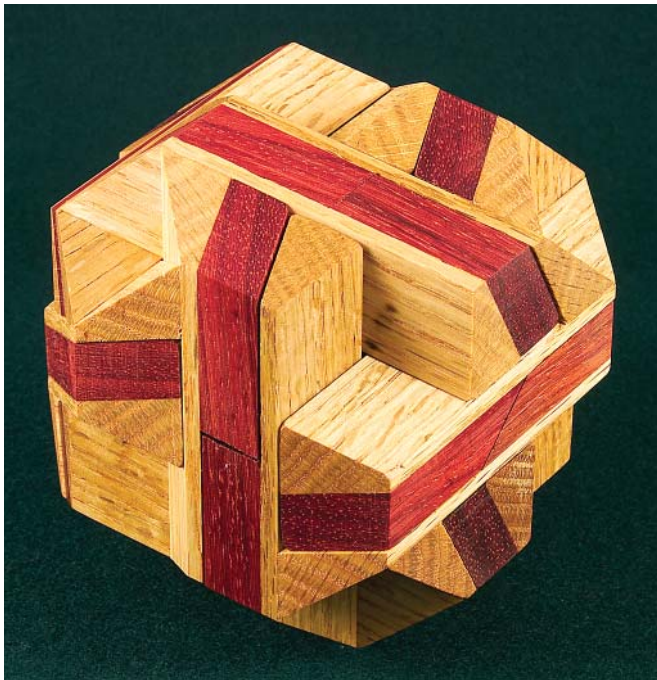
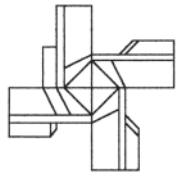

Shouldered Scorpius, Three Plus Three Version (#166-A) in oak & padauk by Stewart Coffin

166-B Shouldered Scorpius, Symmetrical Version

All six pieces are identical and symmetrical. Solution requires coordinate motion. For anyone wishing to make reproductions of either #166-A or B, the one thing to keep in mind is that the critical angle of the bevel where the shoulders engage each other is calculated by vector analysis to be $35\frac{1}{4}$ degrees.

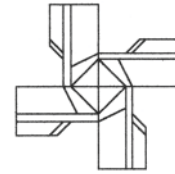

Shouldered Scorpius, Symmetrical Version (#166-B) in oak & poplar by Stewart Coffin

167 The Cruiser

Four simple pieces, two trapezoidal and two triangular, fit into a rectangular tray. When Mary and I go on vacation with friends, we often take along a few puzzles for amusement. This simple puzzle has provided more entertainment than any other puzzle I have ever produced. How can anything that looks so simple be that hard? Used in the IPP-20 puzzle exchange.



The Cruiser (#167) in walnut by Walt Hoppe

168 Cornucopia

This was a reissue of **Cornucopia 105747** (#76-B) in fancy woods.

169 Five-Piece Square Root

The five polyomino pieces fit into a square tray. If the size of the building blocks is one unit of length, then the square tray theoretically measures 5.692 units of length. Design flaws allowed more than one solution.



Five-Piece Square Root (#169) by Stewart Coffin

169-A Four Sleazy Pieces

After the original version of this puzzle was found to have design flaws, this revised laser-cut version was made by Walt Hoppe and used in the IPP-21 puzzle exchange.

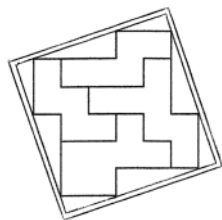

Four Sleazy Pieces (#169-A) in cherry by Walt Hoppe

170 No Name

This unusual 2001 design was proposed as a possible exchange puzzle but never used. The building blocks are rhombic. The angle of the blocks and tray is critical and must be 75.5 degrees. It must also be accurately made or there will be false solutions. A few made in poplar and lauan.

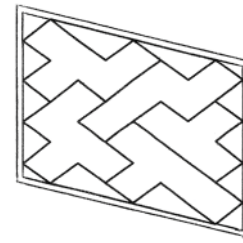

171 Simplified Snowflake

The original 10-piece **Snowflake** (#3) had 167 solutions. This was my attempt to design a “simplified” 9-piece version with only one solution. At the time I lacked a computer puzzle solver program, and my final effort turned out to have almost only one solution. One rough model made.

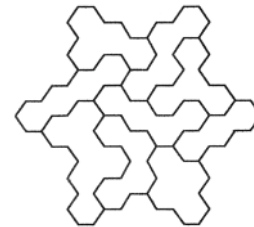

172 Four Z Pentominoes

Four Z pentominoes fit into a square tray. After I had made a few of these simple but neat puzzles and passed them around, I was informed that the idea had already been discovered by others and marketed,

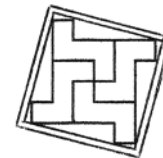

173 No Name

Six dissimilar triomino pieces fit into a hexagonal tray one way only, with two empty spaces. Nearly everyone will try to solve this puzzle by first placing one of the long pieces along one side. The empty space contributes further confusion. A couple rough models made.

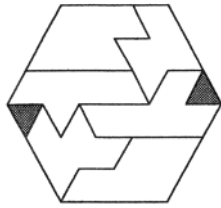

No Name (#173) in cherry by Walt Hoppe

174 No Name

Skip this one. Don't even know now what it was.

175 Nice Try

This and **Nice Try** (#175-A) were six pentominoes in a rectangular tray, with the now familiar skewed grid such as those on the previous page. They had the added confusion of what I call "offset grids" with half-space voids in the center. Unfortunately they both were found to have incongruous solutions, as did several variations. Would have been neat if it had worked. Incidentally I did an exhaustive investigation of designs of this type and reported the results in 2001 in a 13-page paper called *Square Root Type Packing Problems*. But I never have figured out how to look for unwanted extra solutions except laboriously the old fashioned way. Probably someone will eventually figure out how to do this by computer and spoil all the fun.

175-A Nice Try

See **Nice Try** (#175).



Nice Try (#175-A) by Stewart Coffin

176 No Name

One made of Brazilian cherry in 2001. Within this genre there are much better designs than this one.

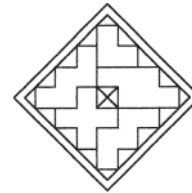

176-A No Name

A slight improvement over #176, using five pentominoes. Two made in 2001.

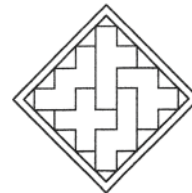

177 No Name

Simply for the sake of being complete, I am including all of these that appear in my serial listing. Perhaps even they have some hidden value. This one had false solutions unless very accurately made, and perhaps even then.

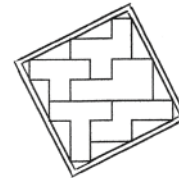

177-A No Name

This is an improved design. It has certain defects, such as two identical pieces and two symmetrical pieces. Nevertheless after exhaustive trial and error, in the end it was the best I could come up with, and is one of my favorites. Several were made using five contrasting fancy woods.

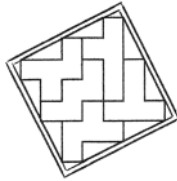

No Name (#177-A) in padauk, oak, poplar, purpleheart & yellowheart with Baltic birch & Brazilian rosewood tray by Stewart Coffin

178 No Name

Six pentominoes fit into a 5x6 tray one way only. The object was to find the optimum combination of dissimilar pentominoes with unique solution, with the aid of the amazing PuzzleSolver3D computer program. This set contains three symmetrical pieces, which made it far from optimum.

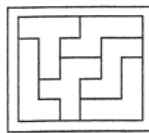

178-A No Name

A more systematic investigation of the design objectives mentioned in #178 led eventually to this design. It uses all five of the non-symmetrical pentominoes plus, by another one of those lucky happenstances, the only symmetrical pentomino that produces a unique solution. This design is truly optimized and cannot be further improved. Pleased with this lucky discovery, I generated a catalog of about twenty other symmetrical problem shapes, some with unique solutions, and also discovered a way of coloring the pieces such that they can be assembled into two different shapes, both with color symmetry. This design now awaits someone to manufacture it.

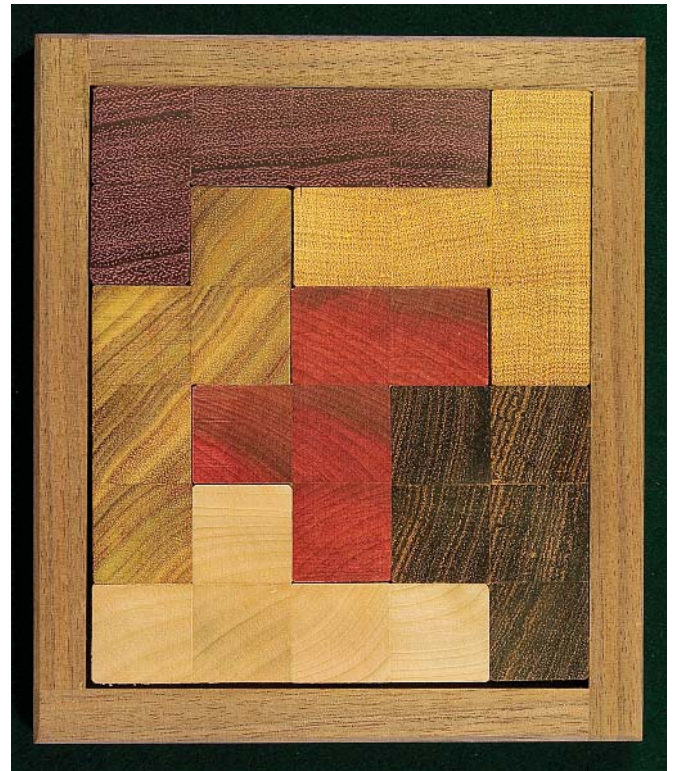
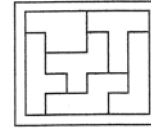

No Name (#178-A) in purpleheart, yellowheart, bloodwood, canarywood, cherry & bocote by Stewart Coffin

179 No Name

This pair of design was another attempt, after the failure of **Nice Try** (#175), to discover a practical design with offset grid and hole in the center. Both were found to have incongruous solutions and had to be discarded. Nevertheless I include one of them here as suggesting a possible area of investigation for someone who has the inclination and patience to look for a practical design with only one solution.

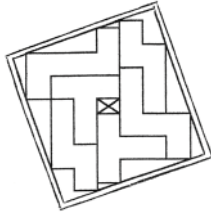

No Name (#179) by Stewart Coffin

179-A No Name

See #179.

180 No Name

Five polyominoes fit into a square tray with hole in center. Practical designs with holes in the center as well as along the sides are difficult to discover because of the even greater likelihood of incongruous solutions. This one appears to be all right.

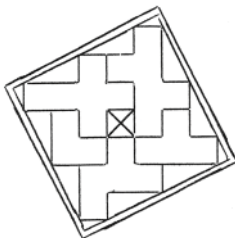

181 No Name

Four non-symmetrical pentominoes and the one non-symmetrical tetromino fit into a 4x6 tray one way only. This is another of those lucky discoveries that is mathematically perfect and cannot be further improved. A few made of fancy woods in 2001.

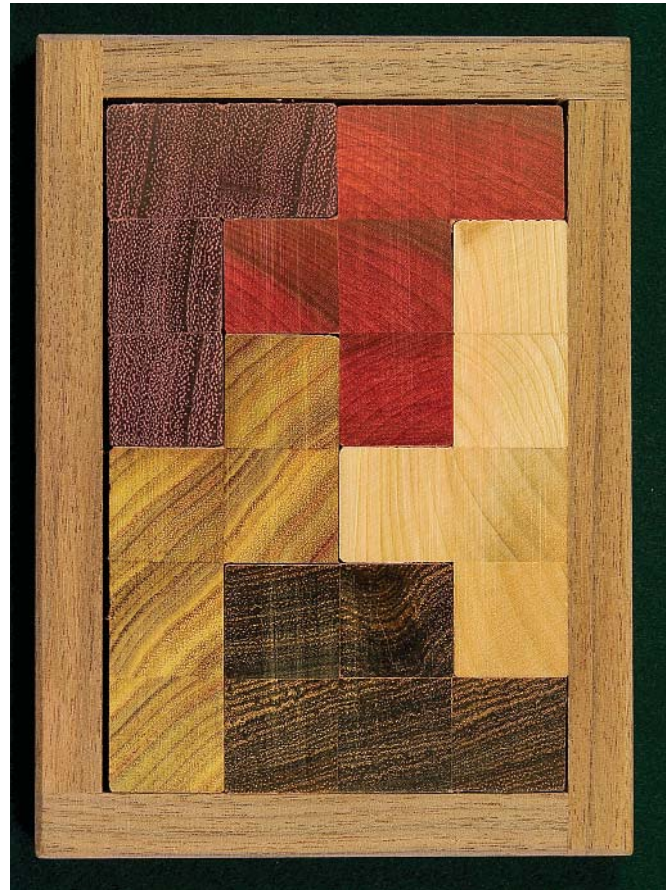
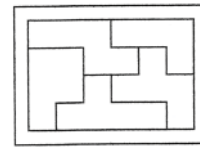

No Name (#181) in purpleheart, bloodwood, canarywood, bocote & cherry by Stewart Coffin

181 Sunrise - Sunset

The improved version of #181 has a two-sided tray. The other side is a 5×5 square with a single block fixed in the center. That side likewise has only one solution. In the deluxe edition, the square blocks are of four contrasting woods, arranged such that the solutions on both sides have color symmetry. Some other problem shapes for this amazing set of pieces are shown here. The numbers indicate the number of solutions. Used in the IPP-22 puzzle exchange.

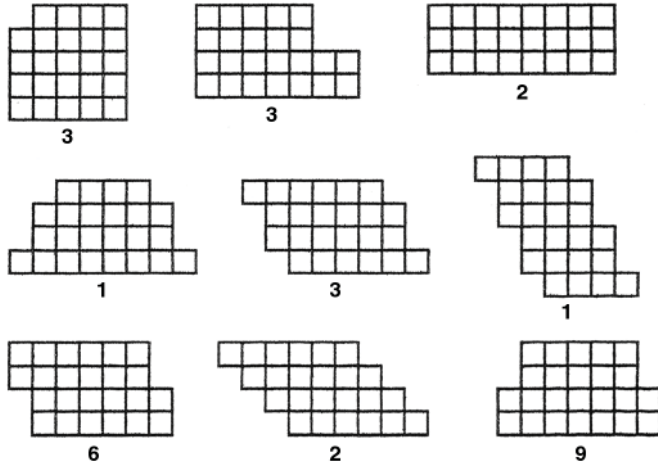

181-A The Castle Puzzle

This puzzle uses the same set of pieces as #181, but the two-sided tray is different. On one side is a house with chimney and on the other side is apparently the same house without the chimney. The supplementary instructions show many other puzzle problems, some easy, some more difficult. The numbers indicate the number of solutions. There are of course in addition to both #181 designs.

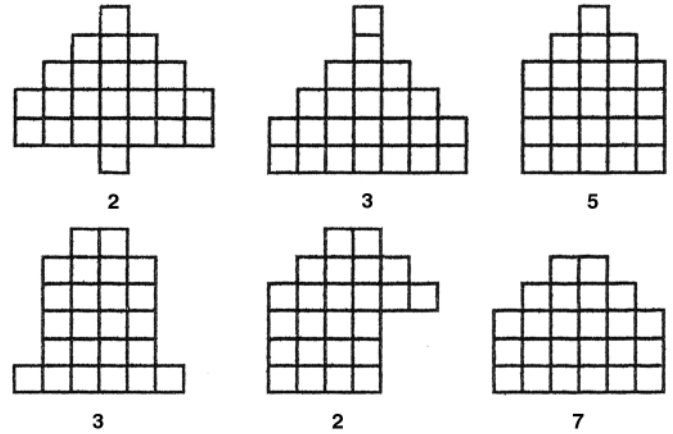

The Castle Puzzle (#181-A) by Stewart Coffin

181-B The Vanishing Trunk Puzzle

Again the same set of pieces and yet another two-sided tray. This one has a tree with trunk on one side, and on the other side apparently the same tree without the trunk. Perhaps the most satisfactory of the three versions of trays.

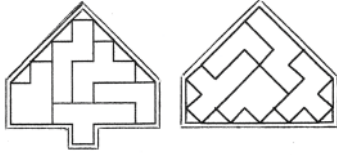

The Vanishing Trunk Puzzle (#181-B) in bocote, Osage orange, purple-heart, paduak & maple by Stewart Coffin

181-C Housing Project

This one is similar to **The Vanishing Trunk Puzzle** (#181-B) but uses a slightly different set of pieces. Again a two-sided tray, with houses on both sides that may appear to be exactly the same but of course are not. Used in the IPP-23 puzzle exchange.

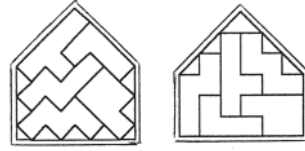

Housing Project (#181-C) side 1, in poplar with oak tray by Stewart Coffin

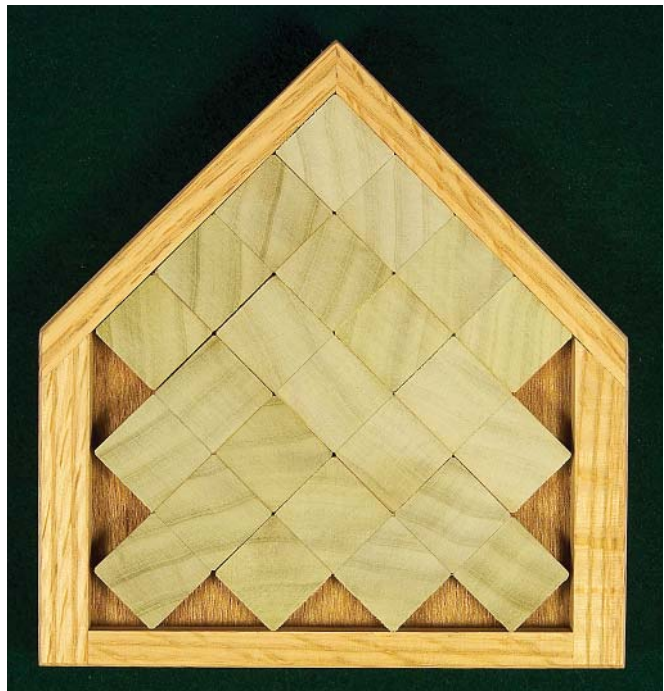

Housing Project (#181-C) side 2, by Stewart Coffin

182 Christmas 2001

Five polyominoes fit into a rectangular tray. Yes, I know. You wonder, haven't we exhausted this genre by now? This one is diabolically more difficult than any of the others, and the reason is that none of the pieces rests comfortably in a corner or along a side.

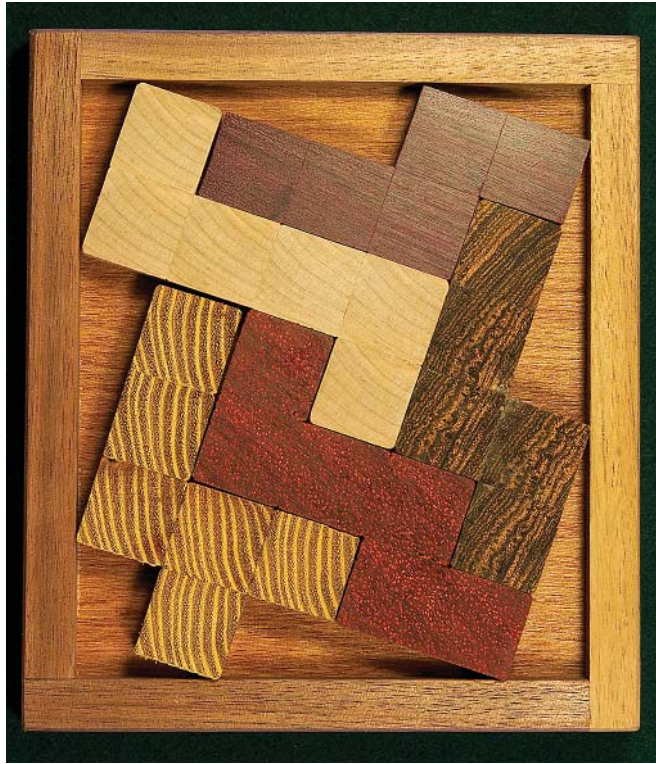
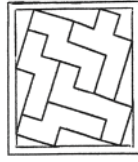

Christmas 2001 (#182) in Osage orange, padauk, bocote, cherry & mahogany by Stewart Coffin

183 No Name

This was yet another try to discover a practical design with offset grids and holes in the center, but like #179 it too was eventually found to have incongruous solutions and had to be discarded.

184-A Looking Glass

Six polyominoes fit into a 5x5 tray with Plexiglas cover by insertion through a slot in the side of the tray. A circular hole in the cover allows the pieces to be maneuvered about with the aid of an eraser. The solution is not straightforward, as it involves shifting some of the pieces around and rotating them.

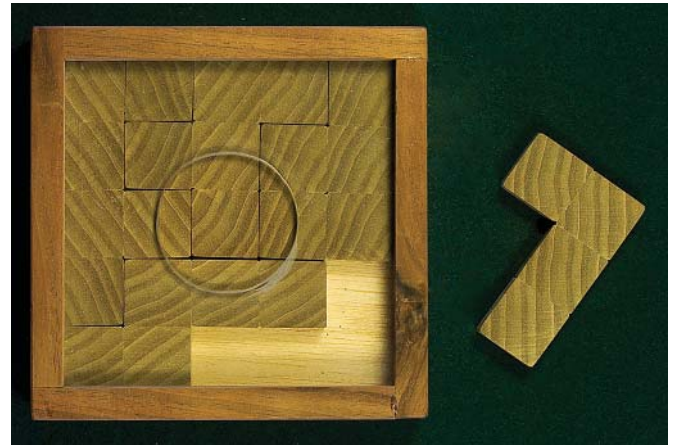
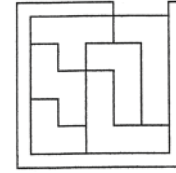

Looking Glass (#184-A) by Stewart Coffin

185 Slot Machine

Seven solid polyominoes pack into a 3x3x3 box by insertion through a 1x2 opening in the Plexiglass cover. Very difficult. A few of these made of maple and Baltic birch in 2002.

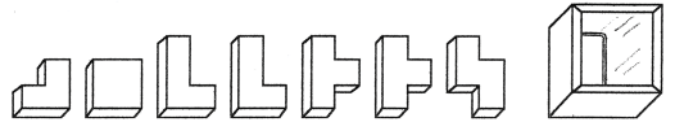

Slot Machine (#185) in maple and Baltic birch by Stewart Coffin

186 Window Pain

This puzzle consists of six polyomino pieces and a two-sided tray. One side is a simple 5×5 square. The other side of the tray has a side slot like **Looking Glass** (#184-A) and a sort of picture frame construction that reduces the top opening to a 4×4 square. The instruction sheet is printed on the 5×5 side and explains the various problems. Eight of these made in 2002.

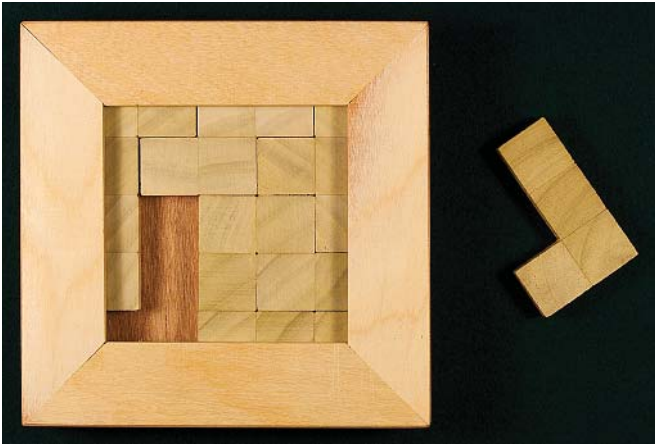
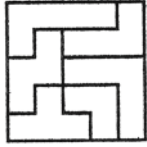

Window Pain (#186) in maple by Stewart Coffin

187 Double Play

The three puzzles in this category all have a 5×5 square two-sided tray. On the back side is a simple framed square for practice exercises, and also the instructions. The front side has a Plexiglas cover with openings cut in it through which the puzzle pieces are inserted. Of these three, **The Decoy** (#187-A) is by far the most difficult and my favorite. It is the only one that requires a slightly loose tray or rounding of corners to solve.

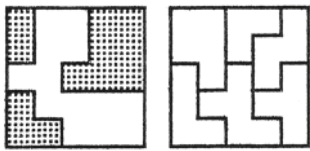

Double Play (#187) in maple by Stewart Coffin

187-A The Decoy

See **Double Play** (#187).



The Decoy (#187-A) in maple by Stewart Coffin

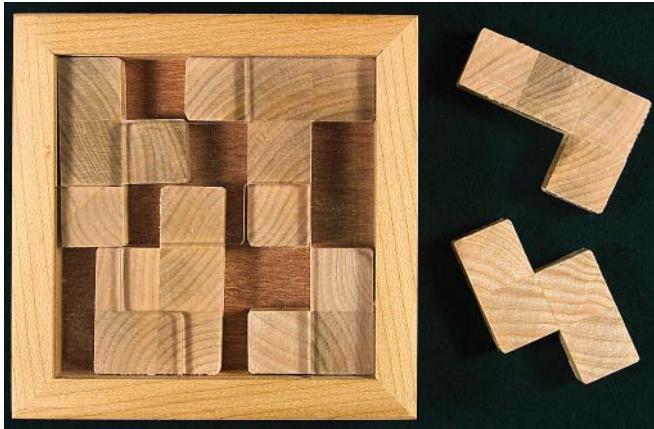

The Decoy (#187-A) partially disassembled

187-B Fourteen Steps

See **Double Play** (#187).

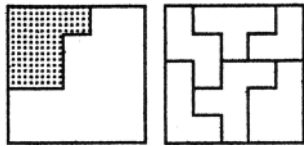

188 Split Box

This unusual packing puzzle consists of four solid pentominoes, one solid tetromino, and a tricky box. The two halves of the box can be joined together two different ways to form either a 2x3x4 box or a 4x6 tray. The box has one solution and the tray has two. Furthermore the two halves of the box can be turned over to form a 3x8 tray, with one solution. The box has a cover, which also serves as a base to hold the two halves together in the 2x3x4. A further improvement in this puzzle would be a better way to hold the two halves together in the other modes. I worked on this a long time but came up blank. One made in 2002.

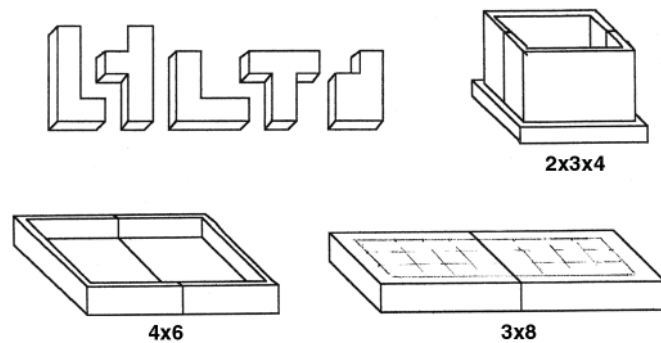

Split Box (#188) by Stewart Coffin

189 Four Blocks in a Box a. k. a. Boxed LUV

As the name suggests, four simple solid polyomino pieces pack into a rectangular box essentially one way only. There are other ways that they almost fit, but the cover on the accurately made box will not slide shut except with the correct solution. This puzzle employs the trick of multiple grids, used by me before in flat puzzles but this is the first time in a 3D packing puzzle. This puzzle is expected to be used in the IPP-23 puzzle exchange renamed **Boxed LUV**.

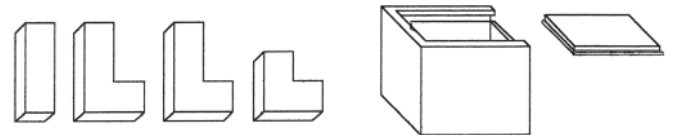

Four Blocks in a Box (#189) in maple with Baltic birch box by Stewart Coffin

190 Four-Piece Separation, Improved

This is an improved version of **Four-Piece Separation** (#86).

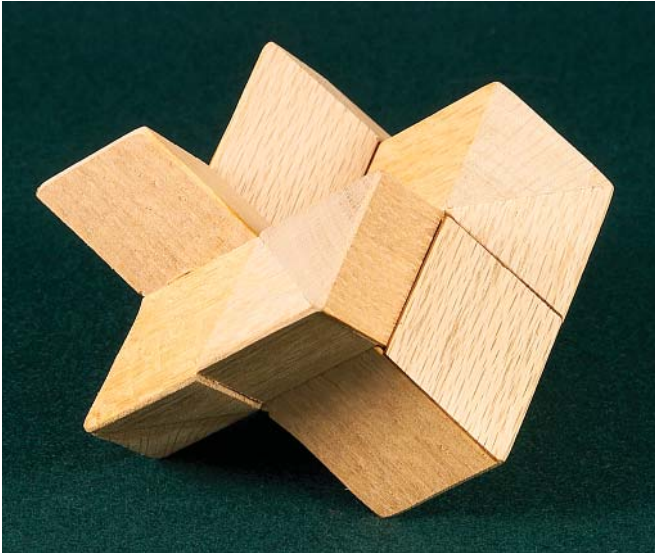

Four-Piece Separation, Improved (#190) in lacewood by Stewart Coffin

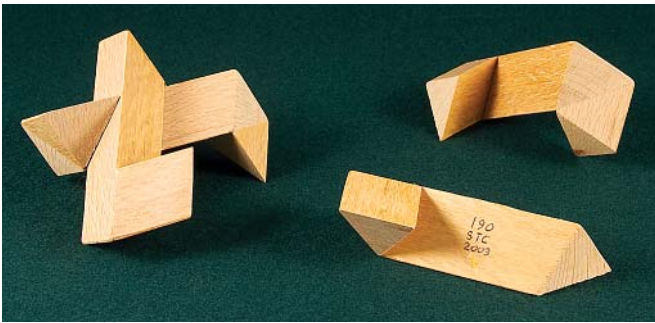

Four-Piece Separation, Improved (#190) partially disassembled.

191 Chicago

This is a revised version of, **Cluster's Last Stand** (#119), simpler and easier to fabricate but equally confusing to assemble. Three kinds of pieces, two of each. Unlike its predecessor, the end blocks are bisected by simple right-angle cuts. The fancy version uses six different kinds of wood. So named because it was introduced at IPP23 in Chicago.

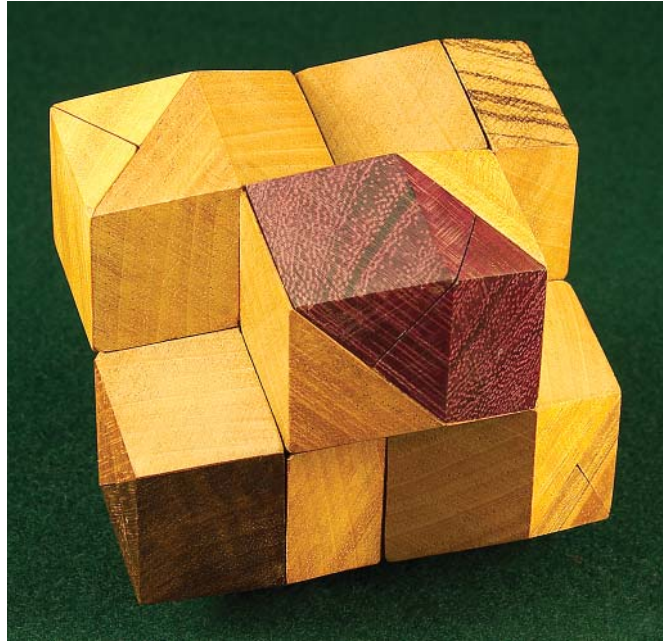

Chicago (#191) in purpleheart, breadnut, zebrawood, imbuya, satinwood, paldao, cherry & teak by Stewart Coffin

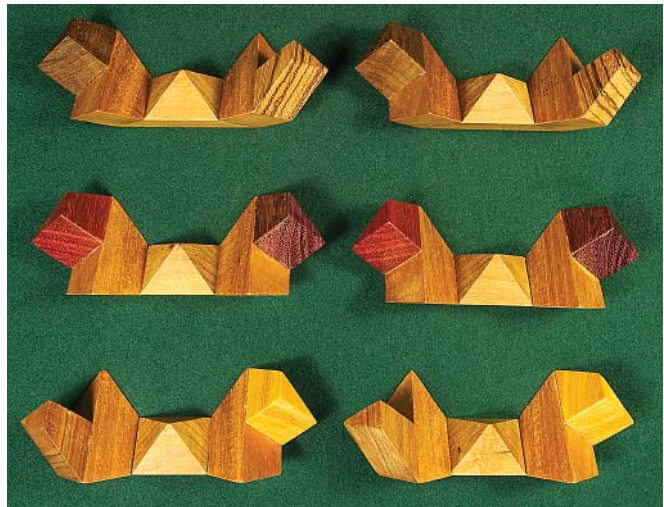

Chicago (#191) pieces

192 Prism Cell

Six dissimilar, non-symmetrical pieces assemble one way only, and in one order only, to form a polyhedral shape perhaps best described as a semi-augmented second stellation. Easy to fabricate because all of the 24 attached blocks are standard prism blocks, hence the name. Confusing to assemble and tricky to disassemble.

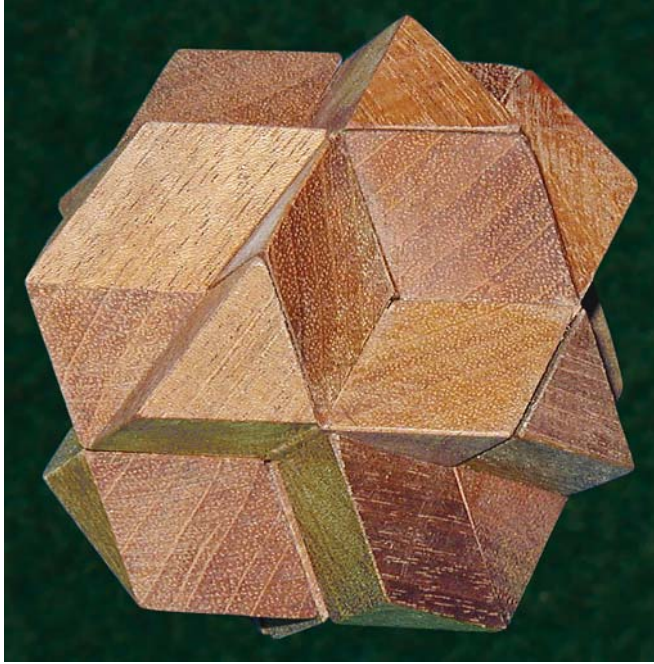

Prism Cell (#192) by Stewart Coffin

193 Computer Killer

An improved version of **Pillars of Hercules III** (#78-B), and a joint design effort with Bob Finn. Five apparent polycube-type pieces are to be assembled to fit into the $3 \times 3 \times 3$ cubic box. In the false solution, one block sticks up out of the box instead of down into the one empty space. The solution is impossible until one discovers that one piece has a doweled joint that can be rotated to the one correct position that permits the solution.



Computer Killer (#193) by Stewart Coffin

194 Triple Play

Four L-shaped polycube pieces, each made from 3 cubic blocks fit into a $2 \times 2 \times 3$ box three different ways. The box is open on one 2×3 side with a 2×2 sliding panel which leaves a 1×2 opening at one end or the other. The pieces can be manipulated through two small holes in the ends of the box.

194-A Triple Play Plus

This version is mechanically identical to **Triple Play** (#194). The difference is the addition of checkering to the pieces, which allows the three distinct mechanical solutions to be uniquely defined by the light and dark patterns (shown in the top row) appearing on top of the assembly. Because of symmetry, the patterns can be reversed.

The three other patterns are shown in the bottom row. Only the checker pattern in the center can be achieved with all three mechanical solutions.

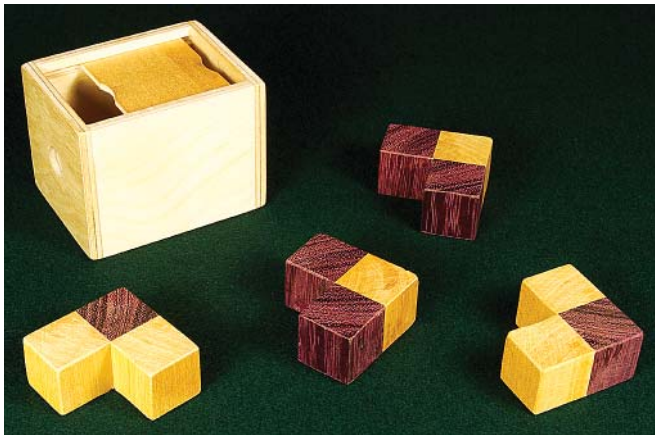
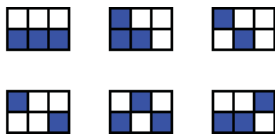

Triple Play Plus (#194-A) in satinwood & purpleheart with Baltic birch box by Stewart Coffin

195 Box Rebellion

An improved version of **Triple Play** (#194) and **Triple Play Plus** (#194-A), four L-shaped polycube pieces, each made from 3 cubic blocks fit into a $2 \times 2 \times 3$ box. The box is open on one 2×3 side with a sliding Plexiglas panel which leaves a 1×2 opening at one end or a 1×1 at the other. The pieces can be manipulated through two small holes in the ends of the box.



Box Rebellion (#195) in paldao with Baltic birch box by Stewart Coffin

EPILOG

Summary

Counting just the numbered, finished designs listed here, there are about 275, starting in 1970 and covering a span of 32 years. In my previous serial listings I included rankings to indicate which I considered to be the most (and least) satisfactory designs, both from my own perspective and as judged by others. I omit that ranking in this publication, but some of it can be inferred from the descriptions. Instead I have chosen to compile the following list in which I have chosen one favorite design to represent each special category of AP-ART puzzlement.

Jupiter (#7) This was always a favorite at craft shows and with customers, as mentioned in the Part 1, although in my view more an example of woodcraft rather than a puzzle. The need for attractive woods in six contrasting colors led me into the wonderful new world of exotic tropical hardwoods and the International Wood Collector's Society.

Scrambled Scorpion (#23) Whenever you explore some new design idea, you find yourself up against the realities of the natural world. Seldom do things work out quite as you might wish, but here they surely did. The six dissimilar, non-symmetrical pieces conveniently proved to have only one solution and essentially only one order of assembly, even more difficult than I had intended. Recently I have made multicolored versions (#164, #164-A and #164-B) that are easier to assemble.

Hectix (#25) and **Hexsticks (#25-A)** This is where it all started. I have been asked many times, "How on earth did you ever come up with that idea?" No one was ever asked that about a checkerboard dissection. It is the surest indication of successful creativity that I can imagine. Incidentally, the closest analogy that I can think of in other fields of creative endeavor is not to be found anywhere in the art world but rather in classical music.

Triangular Prism (#13) This early design could be considered just a simple exercise in combinatorial mechanics. The intriguing geometrical solid that results is just one more example of the wonders which lie hidden in the natural world waiting to be discovered by some lucky explorer. Simple modifications to the underlying structure led to a large family of related designs.

Locked Nest (#22) I include this one as representative of the whole category of pinned sticks and my favorite among them, especially the 6-elbow version, of which only a few were made. There is something profoundly satisfying about joining things together with pins and holes. The first construction toy that I can remember from earliest childhood was a Tinkertoy set, and I rate it the best toy ever invented. Happily, they are still made, of wood believe it or not, and practically unchanged from the original.

Four-Piece Pyramid (#26) This one is representative of the whole family of joined polyhedral block puzzles that are so utterly confusing to assemble. I could have chosen **Octahedral Cluster (#31)**. Unfortunately they demand advanced wood-working skills for the required accuracy and are prone to break-

age unless made with very strong glue joints. Some of mine had doweled joints for extra strength.

Rosebud (#39) Not my first satisfactory coordinate motion puzzle, that was **Three Pairs (#27)**, but long a favorite with puzzle collectors, especially the version made with tulipwood and rosewood. This was the first to include an assembly jig.

Confessional (#68-B) Of all my recent designs created by coordinate distortion, this was one of the most satisfactory and baffling. Too bad it was so hard to make. This is a good example of a familiar, century-old puzzle (Altekruse) which, by a simple modification, becomes something altogether new and different.

Twelve-Piece Separation (#85) Another example of how sometimes nature cooperates perfectly. I discovered the one surprising solution by using the old trick of first gluing it together assembled and seeing if it would come apart. It did, but just barely! For years I shunned including explicit assembly directions, but here I thought it was justified.

All Star (#95) We must include at least one that constructs multiple polyhedral shapes, extending the recreational potential. Others that might have been chosen instead are **Star-of-David (#37)**, **Fusion-Confusion #15-A**, or **Peanut (#67)**. Only about ten of the **All Star** were made. In order to be entirely satisfactory, these types require very accurately made pieces using stable woods.

Burr Noodle (#106) Used as an exchange puzzle at IPP-17 and given out disassembled. It looks simple but I wonder how many were ever assembled. The design required some rather sophisticated (at least by my standards!) calculation of the bizarre angles. I might have carried out some of these mathematical calculations more adroitly 30 years earlier, but they keep the brain cells exercised and I love doing it. How come it is I, the analyst, who derives the most enjoyment from all of this, and not the paying public? It always struck me as strangely unfair.

Fancy This! (#115) A departure from previous designs, this unusual seven-piece polyhedral model is serially interlocking, meaning that all pieces are dissimilar and can be assembled in one order only, with a key piece completing the assembly. The multicolor symmetry provides helpful hints, but one version used as an IPP-17 exchange puzzle used all one wood for added puzzlement.

Cluster's Last Stand (#119) Another coordinate motion amusement but more sophisticated than any of the previous ones. And unlike most, it requires no dexterity, which can be a distraction. It emerged triumphantly from a long process of development and experiment, which included calculation of odd angles. If it had Edward Hordern stumped for over a month, it must be hard.

Few Tile (#133) and **The Cruiser (#167)** These simple yet baffling four-piece puzzles are representative of some recent creations that rely for their success on exploiting the psychology of puzzle solving. In this example, force of habit will invariably lead one to start by fitting a square shape snugly into a square corner, which will immediately misdirect the hapless puzzle

solver down a dead end path. Even better, the more experienced puzzle solvers are often the ones most likely to fall into this trap.

Sphinx (#156) This design evolved from a long line of development and experiment going all the way back to the **Jupiter** (#7), which it very closely resembles in external appearance but not in other ways. The Jupiter was really just an intriguing sculpture in colorful woods that came apart. To make it somewhat more of a puzzle, the six dissimilar woods were arranged in color symmetry, and the problem was not only to reassemble it that way but also to discover four other arrangements with less obvious color symmetry.

What I hadn't yet learned back then was that most persons don't like to follow complicated directions and will be content to just assemble it any way possible. That is how you will nearly always find them assembled. Next in this line was the **Dislocated Jupiter** (#17) in plain wood with identical but non-symmetrical pieces, somewhat more interesting to assemble. Only a few of these were made before being superseded by the **Saturn** (#24) puzzle, which had six pairs of dissimilar non-symmetrical pieces. It was supposed to have only one solution, but Stan Isaacs soon discovered a second.

In 1978, after much trial and error, I came up with what promised to be an improved design with twelve dissimilar non-symmetrical pieces, only one solution, and essentially only one order of assembly. A rough prototype was then made, which was put aside along with dozens of other experimental models and forgotten, only to be rediscovered twenty years later. In 1999 I made a few minor improvements and produced it as the **Sphinx**. It came in three slightly different versions, depending upon the number of dissimilar woods used and their symmetrical arrangement, which in most cases served as an aid to assembly.

Trusting that my assumption of only one possible solution holds up, I do not see any further improvement possible in this particular direction. The dozen or so of these that I have made were all with my most choice exotic woods (depleting my supply) and with doweled joints for added strength. If I had to choose just one example that best represents my AP-ART creations, I suppose this would be it. Ah, but then....

Reflections

As I write this, thirty-two years have passed since my first AP-ART sale, which was on Nov. 27, 1970. It has been a bewildering exercise trying to summarize nearly half a lifetime of haphazard creative effort in these few pages. My grandchildren are older now than our children were when I began. I have been widowed and have moved from Lincoln to join Mary in Andover. My greenhouse/workshop in Lincoln now lies quiet and vacant, basking indifferently in the rays of departed glory. This amazing computer now commands more of my attention than any of my woodworking tools.

The emphasis in this publication has purposely been on the physical description of my various AP-ART designs. What is

really more important, of course, is not the mechanical properties but what they represent in terms of discovery and pleasure. The physical models could be regarded then as just the medium for conveying these fascinating recreations to someone else. As a practical matter, their sales to the public are what provided the income that keeps the whole enterprise going, as well as providing invaluable feedback. But above all else, at least in my experience, the artist is driven first and foremost by the sheer rapture of whatever it is that he or she does and the desire to share it with others. Then and only then comes the practical matter of mastering some technique through which to do it.

In looking back over my Summary list, I find that it is skewed in the direction of the baffling and confusing. Part of the reason for this is that recently much of my creative effort has gone into designing puzzles for the IPP puzzle exchanges. The harder the better, as far as those collectors are concerned. On the other hand, in my *Puzzle Craft* publications, one of the points I have tried to make is that often the simplest things turn out to have the greatest appeal for the general public.

There is a general misconception that we puzzle designers are bent on making our devices ever more diabolical and confusing. I was often asked at craft fairs what was my most difficult puzzle. To begin with, that question is impossible to answer because there are so many different kinds of difficulty. It is usually easy to make a puzzle more difficult simply by increasing the number of pieces, but for what purpose? Aside from the puzzle exchanges, I expect my puzzles to be assembled, and depending upon the situation, I have often included hints such as color symmetry to aid in the solution.

There are many excellent woodcrafters making reproductions of these AP-ART puzzle designs far higher in quality than my original models. These include Tom Lensch, Bart Buie (BartArt Designs), Lee Krasnow (Pacific Puzzleworks), Walt Hoppe, Wayne Daniel, and Steve Smith (Interlocking Puzzles), to name but a few. Most of these craftsmen make them for sale. For more information on how to contact them and find out what might be available for sale, see John Rausch's *Puzzle World* website, www.JohnRausch.com/PuzzleWorld. Also try sources such as eBay, or just do a general search on the Internet under my name or the name of what you are looking for. You may be amazed at some of the items that pop up!

One final comment: I could never really figure out why people bought my puzzles in the first place, and I have been even more amazed at what they were willing to pay. Whatever the rationale, I am deeply grateful for all their generous support over the years. It was I who benefitted the most. For me, the joy was in exploring for new ideas, developing them into practical working models, and then sharing them with friends. I encourage others to discover this fascinating world of geometrical recreations, especially children, and the younger the better.

Stewart Coffin
Andover, Massachusetts
March, 2003

APPENDIX A — BUILDING BLOCKS

Most of the designs based on the diagonal burr have puzzle pieces fashioned from polyhedral blocks derived from dissections of the rhombic dodecahedron. If the geometry of these pieces is not entirely clear to the reader from the drawings alone, some hands-on experience with the blocks should help to clarify things. If the requirement for accuracy is set aside for the moment, they are all easy to make, even with hand tools.

For our purposes, the tetrahedral block is taken as the most basic unit, although of course it could be further subdivided

ad infinitum. Many of the blocks are made equally well from either square or triangular stock

Many of the drawings refer to the building blocks by their letter designation (i. e. **T** for the tetrahedral block).

Many designs also use triangular stick segments of various lengths.

| | Triangular Stock | Square Stock |
|---|-------------------------|---------------------|
| T Tetrahedral Block Basic Unit — Made from triangular stock without waste or square stock with waste | | |
| P Rhombic Pyramid Block Two Tetrahedral Block (T) Units — Made from triangular stock without waste or square stock with waste | | |
| R Right-Handed Prism Block Three Tetrahedral Block (T) Units — Made from either triangular stock square stock without waste | | |
| L Left-Handed Prism Block Three Tetrahedral Block (T) Units — Made from triangular stock without waste or square stock with waste | | |
| O Squat Octahedron Block Four Tetrahedral Block (T) Units or Two Rhombic Pyramid Blocks (P) — Made from square stock with waste | | |
| C Six-Sided Center Block Six Tetrahedral Block (T) Units or Two Prism Blocks (R or L) — Made from square stock without waste | | |
| Δ Triangular Stick Segment Various lengths | | |

APPENDIX B — AP-ART DESIGNS AND CASTLE CREATIONS USED IN IPP EXCHANGES

Most of these names are my original ones and may have been changed for use in the puzzle exchange. Those marked with an asterisk are reproductions made by other craftsmen. I expect this list is incomplete. Corrections and additions are welcome.

| IPP | Design | Name |
|-----|--------|----------------------------|
| 14 | 6 | Four Corners * |
| | 9 | Crooked Notches |
| 15 | 68-A | Leaning Tower of Altekruse |
| | 102 | Incongruous |
| 16 | 52-B | Button Box |
| | 76-B | Cornucopia * |
| | 96-B | Double Notch |
| | 103 | Missing Piece! |
| | 105 | Lock Nut |
| | 107 | Trillium |
| | 109 | Slokum-Pokum |
| 17 | 106 | Burr Noodle |
| | 110 | Octo Burr |
| | 113 | Sliparoo |
| | 115-A | Fancy This! * |
| | 118 | Three Bunnies |
| | 120 | Nine-Piece Pentagon * |
| | 126 | Stew's Scrap Pile |
| 18 | 9-A | Frantix * |
| | 12 | Triangular Prism * |
| | 129-A | Missing Notches |
| | 131 | Six of Diamonds |
| | 132 | Tectonic |
| | 133 | Few Tile |
| 19 | 15-A | Fusion-Confusion * |
| | 27-A | Split Second * |
| | 134 | Outhouse * |
| | 136 | Tangram Plus * |
| | 137 | Engelberg Square * |
| | 144 | Windmill * |
| | 146 | Lime * |
| 20 | 143 | Checkout |
| | 167 | The Cruiser * |
| 21 | 127-A | Make Room * |
| | 169-A | Four Sleazy Pieces * |
| 22 | 181 | Sunrise - Sunset |
| 23 | 153-B | The Trap |
| | 181-C | Housing Project |
| | 189 | Four Blocks in a Box |

APPENDIX C — AP-ART INSTRUCTIONS, DESCRIPTIONS AND OTHER PRINTED MATTER

Instructions

An asterisk indicates that explicit assembly directions are included.

| Design | Name | Year | Pages |
|--------|-------------------------------|------|--------|
| 1 | The Ortho-Cube Puzzle | 1970 | 1 . * |
| 1-A | The Cube Puzzle | 1971 | 1 . * |
| 2 | The Pentablock Puzzle | 1970 | 1 . * |
| 3 | Snowflake (hexagonal booklet) | 1971 | 10 . * |
| 3 | Snowflake Puzzle Worksheet | | 1 |
| 4 | Sirius (The Star Puzzle) | 1971 | 1 . * |
| 4 | Sirius (The Star Puzzle) | 1972 | 1 . * |
| 5 | The Spider-Slider Puzzle | 1970 | 1 |
| 5 | Scorpius | 1971 | 1 |
| 6 | The Four Corners Puzzle | 1971 | 1 . * |
| 7 | Jupiter | 1971 | 1 . * |
| 7 | The Jupiter Puzzle | 1985 | 1 . * |
| 8 | The Nova Puzzle | 1972 | 1 |
| 8-B | Four-Color 2nd Stellation | 1986 | 1 |
| 9 | The Square Knot Puzzle | 1972 | 1 |
| 9 | Supplement for new version | 1986 | 1 |
| 12 | The Triangular Prism Puzzle | 1980 | 1 . * |
| 13-B | The Ring of Diamonds Puzzle | 1995 | 1 |
| 14-A | The Second Stellation Puzzle | 1980 | 1 |
| 14-A | The Second Stellation Puzzle | 1984 | 1 |
| 15 | Triumph | 1974 | 1 |
| 15-A | The Fusion-Confusion Puzzle | 1990 | 1 |
| 18 | Abbie's Puzzle | 1975 | 1 |
| 19 | Pyracube | 1975 | 2 |
| 21 | The Cuckoo Nest Puzzle | 1977 | 1 |
| 21 | Assembly Directions | 1990 | 1 . * |
| 22 | The Locked Nest Puzzle | 1977 | 1 |
| 22 | Solution to six-elbow version | 1977 | 1 . * |
| 23 | The Scrambled Scorpius | 1978 | 1 |
| 23-A | The Egyptian Puzzle | 1993 | 1 . * |
| 24 | The Saturn Puzzle | 1978 | 1 . * |
| 25-A | The Hexsticks Puzzle | 1979 | 1 . * |
| 25-B | Giant Hectix | 1993 | 1 . * |
| 25-C | Four-Color Hexsticks | 1995 | 2 |
| 26 | The Four-Piece Pyramid Puzzle | 1979 | 1 . * |
| 27 | The Three Pairs Puzzle | 1979 | 1 . * |
| 28 | Truncated Octahedra Puzzle | 1979 | 2 |
| 29 | The Half-Hour Puzzle | 1980 | 1 |
| 29 | 21 problem shapes | 1983 | 1 |
| 30 | The Convolution Puzzle | 1980 | 1 . * |
| 31 | The Octahedral Cluster Puzzle | 1980 | 1 |
| 32 | The Broken Sticks Puzzle | 1980 | 1 . * |
| 33 | The Twelve Point Puzzle | 1980 | 1 |
| 33 | The Twelve Point Puzzle | 1984 | 1 |
| 34 | Augmented Four Corners Puzzle | 1981 | 1 |

Instructions (continued)

| Design | Name | Year | Pages |
|-----------------|---|------|-----------------|
| 35, 36 & 40 | Six-Piece Burrs | 1981 | 3 |
| 35 | Solution to Burr 305 | 1984 | 1 |
| | Reprint | 1995 | 1 . * |
| 37 | The Star-of-David Puzzle | 1981 | 1 |
| 37 | The Star-of-David Puzzle | 1990 | 1 . * |
| 37-A | Improved Star-of-David Puzzle | 1990 | 2 . * |
| 39 | The Rosebud Puzzle (obsolete) | 1982 | 1 |
| 39 & 39-A | The Rosebud Puzzle | 1983 | 1 . * |
| 40 | The Interrupted Slide | 1982 | 1 |
| 41 | The Unhappy Childhood Puzzle | 1983 | 1 |
| 42 | The Seven Woods Puzzle | 1971 | 1 . * |
| 43 & 44 | The Sleeper-Stoppers | 1972 | 1 |
| 45 | The Buttonhole Puzzle | 1972 | 1 . * |
| 43, 44 & 45 | Combined | 1984 | 1 |
| 52 | The Pennyhedron (revised) | 1984 | 1 |
| 10 & 53 to 56 | Supplement to Square Knot | 1973 | 1 |
| 60 | The Garnet Puzzle (obsolete) | 1984 | 1 |
| 60 | The Garnet Puzzle | 1985 | 1 |
| 61 | The Setting Hen Puzzle | 1984 | 1 |
| 61-A | The Distorted Cube Puzzle | 1988 | 1 |
| 61-A | The Distorted Cube Puzzle (revised) | 1996 | 1 |
| 62 | The Nine Bars Puzzle | 1983 | 1 |
| 62 | The Nine Bars Puzzle | 1990 | 1 . * |
| 65-A | 30 Notched Rhombic Sticks | 1987 | 1 . * |
| 67 | The Peanut Puzzle | 1988 | 1 |
| 67-B | The Pennydoodle Puzzle | 1989 | 2 |
| 68 | The Confessional Puzzle | 1994 | 1 |
| 68 | Analysis and Solution to | 1994 | 2 . * |
| 68-B | Confessional, Long Version | 1995 | 1 . * |
| 71 | Stucksticks | 1995 | 1 |
| 73-A | Seven-Piece Third Stellation | 1996 | 1 . * |
| 74 & 74-A | Square Face Puzzle | 1990 | 1 |
| 76 | Cornucopia | 1985 | 2 before folded |
| 76 | Instructions for Cornucopia Kit | 1985 | 1 |
| 77 | Pieces-of-Eight Puzzle | 1986 | 2 |
| 77 | Pieces-of-Eight Puzzle (revised) | 1990 | 2 |
| 77 | Pieces-of-Eight Puzzle supplement | 1986 | 2 |
| 80 | Thirty Pentagonal Sticks | 1987 | 1 |
| 81-A | The Two-Three Puzzle | 1987 | 1 |
| 81-B & 81-B1 | Four-Legged Stand | 1987 | 1 |
| 81-C & 81-C1 | Double Four-Legged Stand | 1987 | 1 |
| 83 & 83-A | Pentagonal Stand Puzzle | 1990 | 1 |
| 85 | Twelve-Piece Separation Puzzle | 1988 | 1 |
| 85 | Assembly Directions | 1990 | 1 . * |
| 85-A | The Geodynamics Puzzle | 1994 | 1 |
| 85-A | Assembly Directions | 1995 | 1 . * |
| 87 | Two-Sided Tray (from <i>Puzzle Craft 1992</i>) | 1992 | 1 . * |
| 87-A | Quadrilateral Puzzle (from <i>Puzzle Craft 1992</i>) | 1992 | 1 . * |
| 92 & 92-A | Queer Gear & Second Gear | 1996 | 1 |
| 95 | The All Star Puzzle | 1990 | 2 . * |
| 96, 96-A & 98 | Wild Burrs | 1994 | 1 |
| 96, 96-A & 98-A | Wild Burrs | 1994 | 1 |
| 97 | Crooked Notches | 1994 | 1 |
| 97 | Crooked Notches (revised) | 1995 | 1 |

Instructions (continued)

| Design | Name | Year | Pages |
|---------------|---|------|-------|
| 99 | The Disinclination Puzzle | 1994 | 1 |
| 101 | The Isosceles Puzzle | 1994 | 1 |
| 101-A | The Iso-Prism Puzzle | 1994 | 1 |
| 102 | The Incongruous Puzzle | 1995 | 1 |
| 102 | Analysis and Solution | 1995 | 1 . * |
| 103 | The Missing Piece Puzzle | 1995 | 1 . * |
| 104 | Tech Sticks | 1995 | 2 |
| 105 | Lock Nut (draft only) | 1995 | 1 |
| 106 | Burr Noodle | 1995 | 1 |
| 110 | Spare Pair | 1996 | 1 |
| 111, 111A,B&C | Lost & Found, Lucky Star, Star Dust & A-B-C | 1995 | 1 |
| 112 | Burr Muda | 1995 | 1 . * |
| 112 | Burr Muda Assembly Jig | 1996 | 1 . * |
| 114 | Cluster Plus | 1996 | 1 |
| 115 & 115-A | Fancy This! | 1996 | 1 |
| 117 | Overdrive | 1996 | 1 . * |
| 120 | Nine-Piece Pentagon | 1996 | 1 . * |
| 121 | Pentagonal Star | 1996 | 1 . * |
| 123 | The Chimney | 1997 | 1 |
| 126 | Stew's Scrap Pile | 1997 | 1 |
| 131 | Six of Diamonds | 1997 | 1 |
| 134 | Outhouse | 1998 | 1 |
| 136 | Tangram Plus | 1998 | 1 |
| 138 | Piggy Box | 1998 | 2 |
| 140 | Sticky Sticks | 1998 | 1 |
| 144 | Windmill | 1999 | 1 . * |
| 147 | Pineapple | 1999 | 1 . * |
| 156 | Sphinx | 2000 | 1 |
| 156-A | Sphinx | 2000 | 1 |
| 156-B | Sphinx | 2000 | 1 |
| 157 | Recycled | 2000 | 1 |
| 159 | Seven-Piece Hexsticks | 2000 | 1 |
| 160 & 160-A | Venus | 2000 | 1 |
| 160-B,C&D | Venus | 2000 | 1 |
| 161 | Garnet | 2000 | 1 |
| 164 | Scrambled Scorpius | 2000 | 1 |
| 166 | Shouldered Spider Slider | 2000 | 1 |
| 169 | Five-Piece Square Root | 2001 | 1 |
| 186 | Window Pain | 2002 | 1 |
| 187 | Double Play | 2002 | 1 |
| 187-A | The Decoy | 2003 | 1 |
| 187-B | Fourteen Steps | 2002 | 1 |

Unnumbered and Miscellaneous Publications

| Name | Year | Pages |
|---|-----------|-------|
| Rec-Tangle | 1973 | 1 |
| Occ-Wood | 1973 | 1 |
| Instructions for Various AP-ART puzzles | 1973 | 1 |
| Directions for making Jupiter-Saturn | 1983 | 1 |
| Bill's Baffling Burr | 1984 | 1 |
| Bill's Baffling Burr | 1986 | 1 |
| The Blue Mahoe Story | | 1 |
| The Third Stellation | 1986 | 1 |
| Old puzzle serial list (obsolete) | | 1 |
| Polly's Flagstones | 1993 | 2 |
| Odyssey of the Figure Eight Puzzle | 1993 | 2 |
| Anniversary Newsletter | 1995 | 2 |
| Use of multi-colored woods | 1995 | 1 |
| Serial list of AP-ART puzzles | 1998 | 5 |
| Castle Creation | 1999-2000 | 2 |
| Square Root Type Packing Problems | 2001 | 17 |
| The Incredible Swimmer Puzzle | 2002 | 3 |

Brochures Issued

| Year | Title |
|------|---|
| 1970 | Ortho-Cube, Pentablock, Snowflake |
| 1971 | Sirius Scorpius, Four Corners, Cube, Jupiter |
| 1972 | Sirius Scorpius, Four Corners, Nova, Jupiter |
| 1974 | Star, Four Corners, Triumph, Super Nova, Square Knot, Giant Steps, Hexagonal Prism, Triangular Prism, The General, Dislocated Scorpius, Jupiter, Dislocated Jupiter |
| 1975 | Same as 1974 plus Waffle, Pentablock, Pyracube |
| 1977 | Pin Hole series, Cuckoo Nest, Locked Nest, Snowflake, Pentacube, Jupiter |
| 1978 | Pin Hole series, Cuckoo Nest, Locked Nest, Snowflake, Scrambled Scorpius, Saturn |
| 1979 | Pin Hole series, Cuckoo Nest, Locked Nest, Snowflake, Scrambled Scorpius, Saturn, Hexsticks, Four-Piece Pyramid, Three Pairs, and Truncated Octahedra |
| 1980 | Supplement to 1979 — Half-Hour, Convolution, Octahedral Cluster, Triangular Prism, Broken Sticks |
| 1981 | Scrambled Scorpius, Saturn, Hexsticks, Four-Piece Pyramid, Three Pairs, Half-Hour, Convolution, Octahedral Cluster, Triangular Prism, Broken Sticks, Second Stellation, Twelve Point, Augmented Four Corners, Six-Piece Burr, Star-of-David, Snowflake, Truncated Octahedra |
| 1983 | Three puzzle liquidation sale lists were issued in this year. |
| 1984 | Garnet, Setting Hen, Pennyhedron, Nine Bars |
| 1984 | Inventory list: Snowflake, Second Stellation, Scrambled Scorpius, Hexsticks, Augmented Four Corners, Diagonal Cube, Garnet, Pseudo-Notched Sticks |
| 1984 | Inventory list: Snowflake, Scrambled Scorpius, Hexsticks, Twelve Point, Garnet |
| 1985 | Inventory list: Snowflake, Scrambled Scorpius, Hexsticks, Garnet |
| 1985 | Inventory list: Jupiter, Corner Block, Cornucopia |
| 1985 | Inventory list: Jupiter, Hexagonal Prism, Second Stellation, Triumph, Scrambled Scorpius, Four-Piece Pyramid, Three Pairs, Burr #305, Improved Cluster-Buster, Diagonal Cube, Garnet, Square Face, Cornucopia |
| 1985 | Inventory list: Jupiter, Hexagonal Prism, Second Stellation, Triumph, Corner Block, Garnet, Cornucopia |
| 1985 | Special offer — Cornucopia No. 105747 |
| 1986 | Bill's Baffling Burr, Burr #305, Cornucopia |
| 1987 | Boring Puzzles — Four-Legged Stand, Double Four-Legged, Pentagonal Stand, Thirty Pentagonal Sticks |
| 1990 | Fusion-Confusion, Twelve-Piece Separation |

Magazine Articles on AP-ART

| Publication | Issue |
|--------------------------|------------------|
| New York | December 6, 1971 |
| Esquire | July 1974 |
| Scientific American | January 1978 |
| Fine Woodworking | January 1979 |
| Abacus | Fall 1984 |
| Fine Woodworking | November 1984 |
| World of Wood | September 1985 |
| The Woodworker's Journal | September 1985 |
| The Lincoln Review | September 1985 |
| Scientific American | October 1985 |
| The Woodworker's Journal | March 1986 |
| World of Wood | February 1987 |
| Quark | May 1991 |
| Fine Woodworking | December 1991 |

INDEX

Page numbers in bold type refer to the main entry for a puzzle.

SYMBOLS

3M Company 5, 26, 35

A

A-B-C **90**, 137
Abbie's Waffle **31**, 135
Abel's Chimney. *See* Rock Pile
All Star **78**, 129, 136
Altekruse, William 25
Archimedes Tile **96**
Aries **20**
Atwater, Thomas 5
Augatron **87**
Augmented Four Corners **43**, 77, 135. *See also* Permutated Four Corners Variations **43**
Augmented Second Stellation **29**
Ayer, Jim 17

B

Baxter, Nick 100
Beeler, Mike 68, 101, 102
Betsumiya, Toshiaki 73
Binary Arts 17
Bits & Pieces 36
Bobroff, Saul 106
Box Rebellion **128**
Brickyard **48**
Broken Sticks **41**, 42, 135
Buie, Bart 23, 29, 34, 39, 49, 53, 54, 55, 57, 61, 65, 82, 83, 107, 108, 112
Burr #305 **44**, 136
Burr Circus 92
Burr Muda 27, **90**, 91, 137
Burr Noodle **87**, 129, 134, 137
Buttonhole 6, **49**, 136
Button Box **53**, 134

C

The Castle Puzzle **121**
Checkout **102**, 134
Chicago **126**
Christmas 2000 **123**
Cluster-Buster **49**, 50, 91, 93
 Improved **50**, 93
 Truncated **50**, 93
Cluster's Last Stand **93**, 126, 129
Cluster Plus **91**, 93, 137
Coffin's Improved Burr **44**, 136
Combination Lock **97**
Computer Killer **127**
Concentrix **82**
Confessional **63**, 64, 129, 136
 Long Version **64**, 136
Convolution 14, **39**, 110, 135
Copious Cornucopia **69**

Corner Block **57**
 Improved **57**
Cornucopia **68**, 136
 105747 (#168) **117**
 105747 (#76-B) **69**, 117
 107715 **69**, 134
Creative Puzzles of the World 32
Crooked Notches **80**, 82, 134, 136
The Cruiser **116**
Crystal Blocks **60**
The Cube **16**
Cube Brute **14**
Cuckoo Nest **33**, 58, 85, 135
Cutler, Bill 5, 35, 97, 101, 102
Cylindrix 77

D

DeCordova Museum 6
The Decoy **124**, 137
Defiant Giant **54**
Design No. 72 **65**, 110
 Two-Tiered Version **66**
Diagonal Cube **55**
Disinclination **82**, 87, 137
Dislocated Jupiter **31**, 130
Dislocated Scorpius **31**
Distorted Cube **58**, 136
Double Four-Legged Stand **73**, 136
Double Notch **80**, 81, 134
Double Play **124**, 125, 137
Double Star **12**
Drop In. *See* The Trap
Dudd 97

E

Egyptian **35**, 135
Eight-Piece Tangram 99, **106**
Engelberg Square **100**, 134
Expanding Box **59**

F

Fancy This! **91**, 129, 134, 137
Few Tile **98**, 129, 134
Five-Piece Garnet **104**
 with Coordinate Motion **104**, 105
Five-Piece Octahedral Cluster **40**, 95
Five-Piece Solid Block **70**, 71
Five-Piece Square Root **117**
Foul Dowel **88**
Four-Color Cube **11**
Four-Color Hexsticks **36**, 135
Four-Color Octahedron **11**
Four-Legged Stand 73, 136
 Double **73**, 136
Four-Piece Pyramid **37**, 95, 129, 135
Four-Piece Separation **76**, 126
 Improved **126**
Four-Piece Separation, Improved 76
Four-Piece Serially Interlocking Cube **78**
Fourteen-Piece Square **104**

Fourteen Steps **125**, 137
Fourth Dimension **78**
Four Blocks in a Box **125**, 134
Four Corners **20**, 21, 30, 38, 88, 134, 135
 Augmented **43**, 77, 135
Four Piece Pyramid 40
Four Sleazy Pieces **117**, 134
Four Star. *See* The General
Four Z Pentominoes **117**
Frantix 5, **26**, 134
Fusion-Confusion **30**, 129, 134, 135

G

Garnet **57**, 65, 68, 104, 105, 111, 136, 137
 Five-Piece **104**
 with Coordinate Motion **104**
 New **111**
The General **28**
 Elongate Version **28**
Geo-Logic (series) 5, 9, 11, 12, 20, 24
Geodynamics **76**, 136
Giant Hectix 135
Giant Hexsticks **36**
Giant Steps **26**, 54, 55. *See also* Defiant Giant & Little Giant Steps
Goose **33**
Grizzly Burr **80**, 81, 136

H

Half-Hour **38**, 135
Hectix 5, 13, **35**, 36, 82, 110, 129
 Executive Model 35
Hexagonal Prism **26**, 27
Hexsticks **36**, 64, 77, 86, 129, 135
 Four-Color **36**, 135
 Giant **36**, 135
 Seven-Piece 64, **110**, 137
 Improved 64, 110
Hectix **36**
Hole-in-One **53**
Holmes, Kevin 73
Hoppe, Walt 17, 69, 93, 94, 96, 99, 100, 102, 103, 106, 116, 117, 118
Hordern, Edward 98, 129
Housing Project **122**
HO HO 71
Hydrastone 17

I

Improved Cluster-Buster **50**, 93
Improved Corner Block 57
Improved Four-Piece Separation. *See* Four-Piece Separation, Improved
Improved Seven-Piece Hexsticks. *See* Seven-Piece Hexsticks, Improved
Improved Square Face. *See* Square Face, Improved
Improved Star-of-David. *See* Star-of-David, Improved
Incongruous **85**, 134, 137

Interlocking Checkerboard **14**
Interlocking Puzzles **38, 100**
Interrupted Slide **47, 136**
Isaacs, Stan **35, 130**
Iso-Prism **14, 84, 137**
Isosceles (#101) **14, 84, 137**
Isosceles (#141) **101, 102**

J

Joined Pairs **31**
Jupiter **6, 22, 23, 31, 35, 64, 107, 129, 130, 135**
Dislocated **31, 130**

K

King Pin **33**
Knife Attack!. *See* Five-Piece Garnet with Coordinate Motion
Krasnow, Lee **18, 27, 29, 41, 42, 43, 44, 45, 47, 49, 50, 51, 52, 56, 59, 62, 74, 75**

L

Leaning Tower of Altekruze **64, 134**
Lemon **103**
Lensch, Tom **20, 30, 31, 39, 46, 49, 50, 70, 78, 102**
Lime **103, 134**
Little Giant Steps **54**
Little Rocket **77**
Locked Nest **33, 34, 71, 74, 129, 135**
Three-Hole Version **33**
Lock Nut **86, 134, 137**
Looking Glass **124**
Lost and Found **89, 137**
Lucky Star **89, 137**

M

M. I. T. Lincoln Laboratory **9**
Make Room **96, 134**
Meteor **82**
Mikusinski's Cube **9**
Minihedron **52**
Missing Notches **97, 134**
Missing Piece! **85, 134, 137**
Mosaic **14**

N

Nest Construction Set **71**
New Garnet **111**
Nice Try (#175) **118, 120**
Nice Try (#175-A) **118**
Nine-Piece Pentagon **93, 134, 137**
Nine Bars **58, 136**
Nonesuch **88**
Nova **12, 24, 29, 135**
Nylon Products **5**

O

O'Brien, Gus **9**
Obstructed Pins **74**
OCC-Wood **13**

Octahedral Cluster **40, 95, 129, 135**
Five-Piece **40, 95**
Octahedron **102**
Four-Color **11**
Octo **10**
Octo Burr **88, 134, 137**
Ortho-Cube **16, 135**
Outhouse **98, 106, 134, 137**
Overdrive **92, 137**

P

Pagoda **54, 55**
Giant **55**
Patio Block **73**
Peanut **60, 61, 62, 63, 129, 136**
Pennydoodle **63, 78, 136**
Pennyhedron **52, 53, 63, 136**
Three Piece **52**
Tricky Pair **53**
Zig-Zag **52**
Pentablock **16, 135**
Pentacube **16**
Pentagonal Stand (#83) **73, 136**
Pentagonal Stand (#83-A) **74, 136**
Pentagonal Star **94, 137**
Permutated Four Corners **77**
Pieces-of-Eight **70, 136**
Piggy Box **101, 137**
Pillars of Hercules **70**
II **70**
III **70, 127**
Pin-Hole **32, 33, 57, 88**
Pineapple **103, 137**
Plus 2 **25, 55**
Pluto **10**
Pretty Puzzle **71**
Prism **10, 11**
Prism Cell **127**
Pseudo-Notched Sticks **58, 67**
Puzzle Craft
1985 **7**
1992 **7**
Puzzle Solver 3D **3**
Puzzle World (website) **7, 131**
The Puzzling World of Polyhedral Dissections **7**
Pyracube **32, 58, 135**
Pyramid. *See* Four-Piece Pyramid

Q

Quadrilateral **76, 77, 136**
Queer Gear **77, 78, 136**

R

R-D-16 **95**
Rec-Tangle **13**
The Recycled Puzzle **109**
Redemption **85**
Reluctance **87**
Rhombic Blocks **94**
Ring of Diamonds **28, 135**
Rock Pile **95, 137**
Rosebud **46, 47, 97, 129, 136**

Assembly Jig **47**
Rosebud Assembly Jig **97**
Rubik's Cube **6**
RUFTY **14**

S

Sam Span Company **5**
Saturn **31, 35, 64, 107, 135**
Scorpius **19, 31, 34, 64, 115, 135**
Dislocated **31**
Scrambled **34, 35, 111, 113, 129, 135, 137**
4 Woods **113**
6 Woods **113**
Seven-Piece **105**
Shouldered **109**
Scrambled Legs **111, 112**
Scrambled Scorpius **31, 34, 35, 111, 113, 129, 135, 137**
4 Woods **113**
6 Woods **113**
Seven-Piece **105**
Second Gear **78, 136**
Second Stellation **29, 135**
Augmented **29**
Serially Interlocking Cube. *See* Four-Piece Serially Interlocking Cube
Setting Hen **58, 136**
Seven-Piece Hexsticks **64, 110, 137**
Improved **64, 101, 110**
Seven-Piece Scrambled Scorpius **105**
Seven-Piece Third Stellation **66, 91, 136**
Seven-Piece Third Stellation, Modified **66**
Seven Block **9**
Seven Woods **10, 47, 48, 82, 136**
Shatterblock **63**
Shouldered Scorpius **109**
Simple Version **115**
Symmetrical Version **116**
Three Plus Three Version **116**
Shouldered Spider Slider **115, 137**
Siamese Locked Nests **34**
Sirius **18, 135**
Six of Diamonds **98, 134, 137**
Skor-Mor **9, 11, 12, 13, 20, 24**
Slant Six **81, 98, 136**
Sleeper-Stopper **6, 48, 136**
Super **48**
Slider **98**
Sliparoo **91, 134**
Slocum, Jerry **82, 102**
Slokum-Pokum **88, 134**
Slot Machine **123**
Snowflake **5, 17, 117, 135**
Simplified **117**
Span-Atwater **17**
Spare Pair **88, 137**
Sphinx **35, 64, 107, 130, 137**
5 Woods **107**
15 Woods **107**
30 Woods **107, 108**
Spider-Slider **19, 135**
Shouldered **137**
Spinner **9**
Four-Color **9**

Spirus **12**
 Split Second **38**, 134
 Split Star **68**, 113
 Diminished
 Hexagonal Column **114**
 Octahedral **114**
 Six-Pointed Star **115**
 Square Column **114**
 Triangular **115**
 Simplified **113**
 Square Face **67**, 136
 Improved **67**
 Square Knot **25**, 26, 54, 55, 63, 71, 135, 136
 Star 38
 The Star **18**, 135
 Star-of-David **44**, 45, 78, 129, 136
 Improved **45**, 136
 Star Dust **89**, 90, 137
 Stew's Scrap Pile **96**, 134, 137
 Sticky Sticks 64, **101**, 110, 137
 Stucksticks **64**, 101, 110, 136
 Sunrise - Sunset **121**, 134
 Superstar 49, **51**
 Superstar II **51**
 Superstar II 51
 Super Nova **29**
 Super Sleeper-Stopper **48**, 136

T

Tangram
 Eight-Piece **106**
 Tangram Plus **99**, 106, 134, 137
 Tauri **9**
 Tech Sticks **86**, 137
 Tech Sticks in Four Woods **86**
 Tectonic **98**, 134
 Teddy Burr **79**, 81, 98, 136
 Tetrahedron **11**
 thermosetting resin 17, 60
 The Chimney 137
 The Cruiser 129, 134
 The Cube 16, 135
 The General 28
 Third Stellation **51**
 Seven-Piece **66**, 91, 136
 Modified **66**
 Thirty Notched Rhombic Sticks **60**, 136
 Thirty Notched Sticks **59**
 Thirty Pinned Pentagonal Sticks **71**, 72, 136
 Three-Piece Pennyhedron 52
 Three-Piece Separation **76**
 Three Bunnies **92**, 134
 Three Pairs 10, **37**, 129, 135
 Variations **38**
 The Trap (#153-A) **105**
 The Trap (#153-B) 106
 Trench Enterprises 77
 Triangular Prism **27**, 28, 90, 129, 134, 135
 Elongate Version **27**, 28
 Triful **14**
 Trillium **87**, 134
 Triple Cross **71**
 Triple Play **128**
 Plus **128**

Triumph **30**, 135
 Companion **30**
 Truncated Cluster-Buster **50**, 93
 Truncated Octahedra **38**, 135
 Twelve-Piece Separation **74**, 75, 76, 86, 129, 136
 Twelve Point **41**, 135
 TWIS-T **14**
 Two-Sided Tray **76**, 77, 136
 Two-Three **71**, 136
 Two Tiers **68**, 105
 with Scorpius Outer Shell **105**
 Two Tiers with Scorpius Outer Shell **105**

U

Unhappy Childhood 6, **47**, 136
 Uni **12**

V

The Vanishing Trunk Puzzle **122**
 van Grol, Rick 73
 van Kammen, Andre 3
 Vega **49**, 89
 Vega II **49**
 Venus **110**, 111, 137
 One Wood **111**
 5 Woods **111**
 with Matched Pairs 111
 6 Woods **111**

W

Wild Burrs 136
 Windmill **102**, 134, 137
 Window Pain 137
 Wookey Hole 16
 Wunder Bar **14**

Y

Yogi Burr **81**, 136

Z

Z-Puzzle **10**
 Zig-Zag Pennyhedron 52
 ZOOM, PBS children's program 31



ISBN 0-9666361-2-0



90000>



9 780966 636123